



Received: 30/10/2024  
Original Research Article

Revised: 06/02/2024

Accepted: 18/03/2025

Published online: 31/03/2025



Open Access under the CC BY -NC-ND 4.0 license

UDC 536.722

## THE EFFICIENCY DEPENDANCE OF A SINGLE-CIRCUIT POWER UNIT WITH A HELIUM-COOLED REACTOR AND A HYDROGEN MODULE ON THE DEGREE OF REGENERATION

Nurym K.A.<sup>1</sup>, Antonova A.M.<sup>2</sup>, Sakipov K.E.<sup>1\*</sup>, Vorobyev A.V.<sup>2</sup>, Stetsov N.V.<sup>2</sup>

<sup>1</sup>L.N. Gumilyov Eurasian National University, Astana, Kazakhstan

<sup>2</sup>Tomsk Polytechnic University, Tomsk, Russia

\*Corresponding author: [sakamer2100@gmail.com](mailto:sakamer2100@gmail.com)

**Abstract.** *The most attractive single-circuit scheme of the power unit was chosen. Helium at the outlet of the reactor core enters the steam generator, where it gives part of the heat to generate highly superheated steam for the electrolysis plant. Next, helium operates in a closed gas turbine cycle with heat recovery. A gas-cooled reactor with a turbine and compressor allows the use of a thermodynamic cycle with high efficiency. A series of design calculations of the regenerator for various degrees of regeneration have been performed. A series of assessments of the effect on the real resistance of the regenerator from the high- and low-pressure sides have been carried out. The thermal scheme of energy production is calculated in accordance with a series of design calculations of the regenerator.*

**Keywords:** reactor, helium, gas-turbine installation, regenerator, hydraulic resistance, aerodynamics resistance.

### 1. Introduction

In recent years, there has been a significant development in gas turbine construction worldwide, in particular, the expansion of their application areas, an increase in energy efficiency parameters, and the improvement of units and circuits in order to increase efficiency and take into account compliance with environmental requirements [1 - 4]. Studies have been conducted that include coupling a high-temperature gas-cooled nuclear reactor with a closed-cycle helium gas turbine energy conversion system [1]. In [2] the accumulated experience from the operation of helium gas turbine units and associated test facilities is considered in order to determine the conditions and factors for more efficient and safe operation. It has been established that a helium turbine with liquid characteristics allows operation between normal temperatures of the exhaust gas of the upper turbine and temperatures of liquid hydrogen [3]. The results of a study of coupling a high-temperature gas-cooled nuclear reactor with solid oxide electrolyzers for large-scale hydrogen production are shown in [4]. The combined system can achieve sufficiently high efficiency values.

A single-circuit power unit with a helium-cooled reactor and a hydrogen module is being created on the basis of a closed gas turbine unit (GTU), in which the use of regeneration is a necessary condition for achieving a sufficiently high efficiency. The temperature of the exhaust gases after the turbine is high and when working on a simple Brighton cycle, a large amount of heat is released into the environment. In a regenerative cycle, part of the heat can be returned to the cycle by transferring it from the helium spent in the turbine to the helium compressed in the compressor before it enters the nuclear reactor. The degree of regeneration ( $\sigma$ ) can vary in

a certain range, the value of which is determined by the values of the helium temperature at the outlet of the turbine and at the outlet of the compressor, which, in turn, depend on the degree of pressure increase in the compressor. According to [5] "there are 2 types of GTU regenerator designs: plate and tubular. Regenerator heat exchangers must meet the following requirements: be compact and durable enough to be used in cycles with a high degree of compression, have a high coefficient of heat transfer on the gas side, ease of manufacture, and low cost of these heat exchangers. Tubular heating surfaces have been most fully studied and presented, the advantages of which include: the possibility of use at high pressures, simpler layout, reliability, ease of manufacture and maintenance. Tubular regenerators have tube boards, housings, and other parts that sometimes exceed the weight of the active part of the heating surface in terms of their weight and dimensions. Reducing the diameter of the tubes, which is a significant factor affecting the reduction of the dimensions of the heat exchanger, is possible only up to the known practically permissible limits. In order to increase the efficiency of tubular heating surfaces, transverse and longitudinal fins are used [6 – 13].

The purpose of this study is to determine the maximum efficiency of the heat exchange process of the unit, taking into account the degree of regeneration and the hydrodynamic characteristics of the regenerator. In this case, preference is given to the design of a tubular counter-current heat exchanger with transverse finning of heat exchange pipes, due to the widespread use of these devices, compactness and ease of maintenance.

## 2. Main part

### 2.1 Theoretical approach

In the considered single-circuit installation, the working fluid of the GTU and the coolant of the reactor is helium, which operates in a closed gas turbine cycle with heat regeneration (Fig. 1). The regenerator is a helium-helium countercurrent tubular heat exchanger, the blocks designations in it are shown in Fig. 1. Part of the heat obtained in the reactor core; helium is given in the steam generator to generate highly superheated steam for the electrolysis installation of the hydrogen module. The supply and removal of heat in the apparatus (reactor, steam generator, regenerator, cooler) occurs in isobaric processes with some pressure losses; the processes of expansion and compression of helium in the turbine and compressor are adiabatic in nature.

To study the parameters of the installation in a wide range of changes in the initial parameters, the method of calculating the thermal circuit of the GTU was used, implemented in the form of a model and a program in the Excel and COOLPROP spreadsheet package. The model is based on the equations of energy balances and patterns of adiabatic processes of expansion and compression of helium gas using relative internal efficiencies to account for non-isotropy in real processes. The reliability of the model and calculation method was checked by manual calculations, the calculation error did not exceed 2.5%.

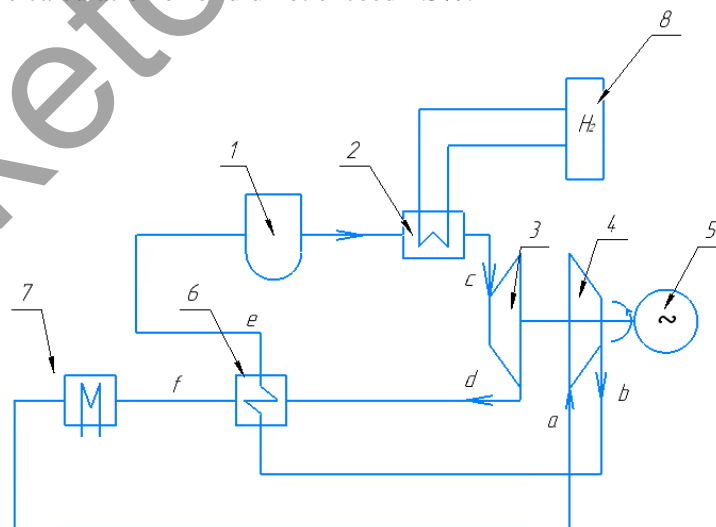

**Fig.1.** Diagram of a closed nuclear power plant with heat recovery and a hydrogen complex [9]:  
 1 – reactor, 2 – steam generator, 3 – turbine, 4 – compressor, 5 – generator, 6 – electric generator,  
 7 – cooler, 8 – electrolyzer.

Regenerator resistance values are calculated for different values of the regeneration degree. Calculation results of the regenerator resistance coefficient on the degree of regeneration are shown on Fig.2. Further, according to the previously used algorithm [6] variant calculations of the thermal circuit were carried out taking into account the increase in regenerator resistance with increasing  $\sigma$ .

As an assumption, it is assumed that when the degree of regeneration changes, only the resistance of the regenerator changes, and the resistance of the other elements (core, steam generator, compressor-gas turbine tract, heat exchanger-cooler, nozzles and pipelines) remain unchanged and can be excluded from consideration. With an increase in the degree of regeneration, the value of the heat transfer surface of the regenerator increases not linearly, but much faster. The deeper the regeneration, the larger the surface is required to transfer heat to the unit. Therefore, the degree of regeneration has a limited value, determined by a technical and economic analysis, which will have to be performed in the future.

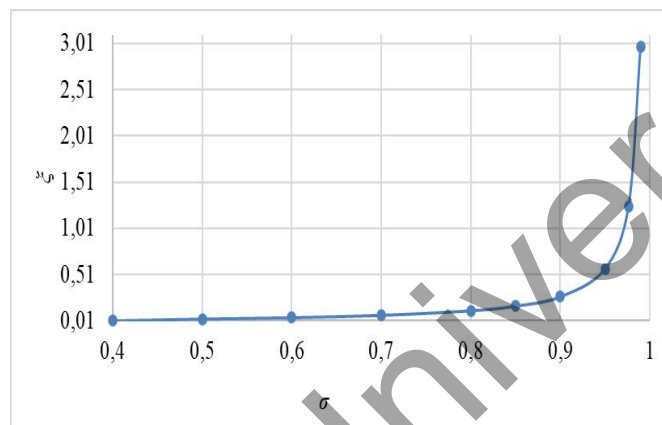

**Fig.2.** Dependence of the regenerator resistance coefficient on the degree of regeneration  $\xi$ ,  $\sigma$

The paper [10] the results of a calculated assessment of the dependence of the characteristics of a hydrogen complex HTU on changes in the resistance of the regenerator based on its hyperbolic dependence on the degree of regeneration were presented [11]. In this paper, the aim is to establish the effect of the hydraulic resistance of the regenerator on the efficiency of the installation based on the design calculation of the regenerator. For various values of the degree of regeneration, the main characteristics of a shell-and-tube regenerative heat exchanger are calculated, such as the heat transfer coefficient, the heat exchange surface area, the length of heat exchange tubes, the diameter of the pipe board, and hydraulic resistance. There are main parameters in theoretical process are presented in Table 1.

**Table 1.** GTU's indicators for theoretical process

No.	$\sigma$	$\xi_{pl}$	$\lambda_l$	$p_c$ , MPa	$G$ , kg/s	$H_T$ , kJ/kg	$H_K$ , kJ/kg	$N_s$ , MW	$\Delta\eta$ , %	Efficiency y
1	0.4	0.01	0.96	69.12	62.96	1315	899	25.16	-24.13	0.210
2	0.5	0.015	0.955	68.76	67.57	1299		26.01	-26.72	0.220
3	0.6	0.0225	0.9475	68.22	72.90	1276		26.43	-30.74	0.238
4	0.7	0.035	0.935	67.32	79.16	1236		25.68	-37.74	0.259
5	0.8	0.06	0.91	65.52	86.586	1154		21.26	-52.63	0.284
6	0.85	0.068	0.90	64.92	90.84	1068		14.77	-68.52	0.297

**Note:**  $\lambda_l$  – coefficient of losses along the high-pressure path,  $p_c$  – pressure in front of the turbine,  $G$  – coolant consumption,  $H_T$  – heat transfer on the turbine,  $H_K$  – heat transfer on the compressor,  $N_s$  – electrical power,  $\Delta\eta$  – relative efficiency difference, Efficiency – efficiency coefficient, when determining the values, an algorithm was used in [6].

## 2.2 Real approach

When designing the device, in order to increase the efficiency of the heat exchange process in gas-gas media, annular finning was used, (Fig. 3). Below schematically shows the transverse and longitudinal sections of the heat exchange tube bundle with characteristics values (diameters, lengths, etc.) that were used in the calculations.

Figure 4 shows a model of the movement of the coolant and working fluid in the regenerator. The heated medium is high-pressure helium in the tubes at a temperature of  $T_b$  and the heating medium is hot helium from the turbine at a temperature of  $T_d$  ( $T_d > T_b$ ). Exhaust temperatures are indicated by  $T_f$  (at the exit from the intertubular space) and  $T_e$  (before entering the reactor).

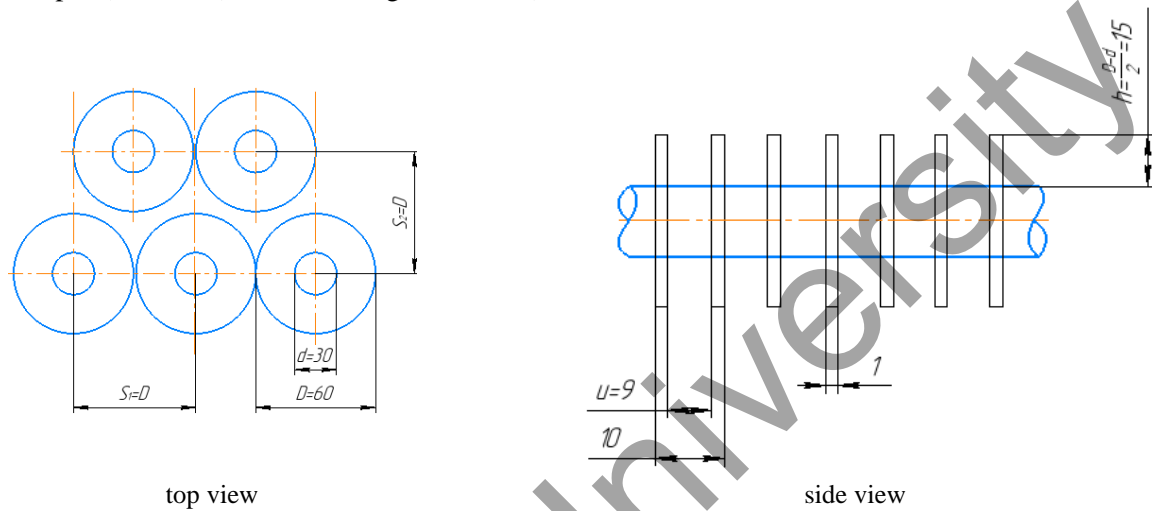

**Fig.3.** Characteristics of the fins of the heat exchange bundle of pipes:  $S_1$ ,  $S_2$  – the distance between the tube centers;  $D$  – diameter of the ribs,  $U$  – the distance between adjacent edges,  $h$  – edge height

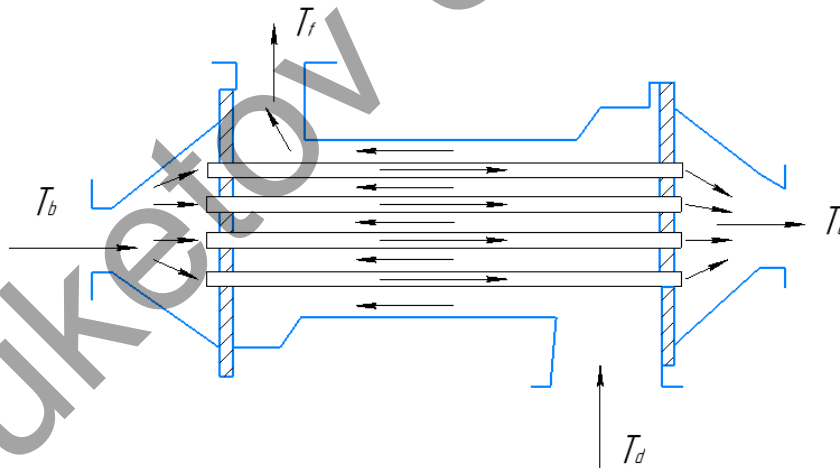

**Fig. 4.** Model of the movement of the coolant and the working fluid in the regenerator.

Calculations were carried out using Excel spreadsheets and the COOLPROP module for thermophysical parameters of gases. The initial data are assumed to be the same as in [11]: the temperature of helium at the inlet to the gas turbine is 1123 K; the temperature of helium at the outlet of the reactor is 1223 K, at the inlet to the turbine is 1123 K; the pressure of helium at the inlet to the compressor is assumed to be 3.0 MPa; the degree of pressure increase is 2.4. Calculations were carried out for the thermal power of the reactor is equal to 200 MW. Parameters of steam generated for the electrolysis plant of the hydrogen module: pressure 1 MPa, temperature 800°C. The range of changes in the degree of regeneration: from 0.7 to 0.9 in accordance with the results of the work [11]. For clear understanding (red – theory, blue – reality).

Having obtained the values of pressure resistances in design calculations and having constructed the dependence of pressure losses on the degree of regeneration, it is worth noting that the nature of the dependence has been preserved (hyperbolic), which indicates the correctness of the calculations. However, the real resistances turned out to be slightly lower than those accepted in the theoretical approach. Figure 5-7 demonstrate parameters which reflect the real influence of aerodynamic resistance on cycle performance indicators. In the real cycle, the temperature of point  $e$  is lower due to pressure losses in the tube space of the regenerator. Since the temperature behind the reactor is constant, the  $\Delta T$  of the reactor increases.

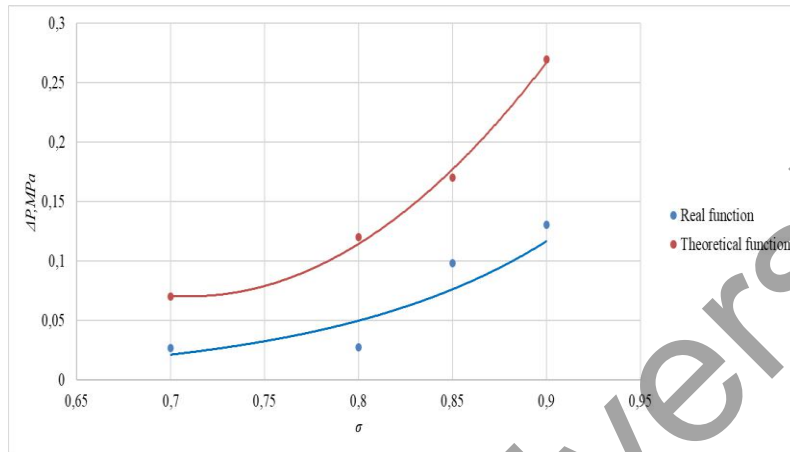

**Fig.5.** Dependence of the pressure loss value on the degree of regeneration

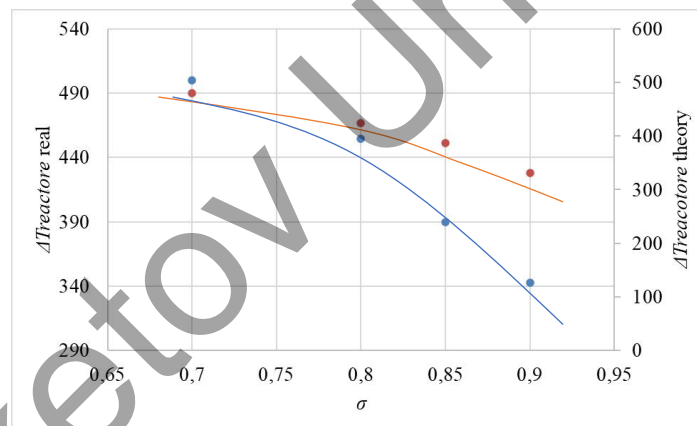

**Fig.6.** Dependence of helium heating in the reactor on the degree of regeneration

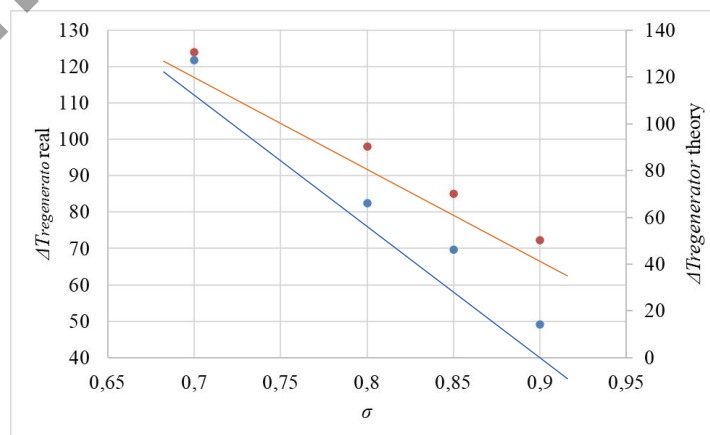

**Fig.7.** The dependence of the temperature difference on the degree of regeneration

### 3. Results and discussion

Evaluation the aerodynamic resistance let recalculate main parameters for scheme (Fig. 1). As for the comparison it can be state with certainty that resistance in the theoretical process turned out to be higher, which significantly affected the efficiency of the cycle. This is due to the low resistance along the low-pressure path and low flow rates of heating helium at the inlet to the regenerator. The main results are in table 2 below.

**Table 2.** GTU's and regenerator indicators for real process

No.	$\sigma$	Efficiency, %	$Q_{reg}$ , MW	$\Delta T$ , K	$G$ , kg/s	$wl$ , m/s	$\Delta p$ , MPa	$l$ , m	$D$ , m	$\varepsilon$
1	0.70	28	120	121	77	5	0.02	6.9	4.15	2.4
2	0.80	29	150	82	84	5	0.03	11.7	4.44	3.7
3	0.85	25	168	69	98	5	0.09	18.8	4.63	5.8
4	0.90	17	186	49	112	5	0.13	32.0	4.84	9.3

As for the efficiency (Fig. 9) of the cycle itself, the area of an acceptable degree of regeneration lies in the range from 0,7 to 0,8, since after a value of 0,9 we get superhigh resistance and high speeds, which negatively affects the efficiency of the cycle as a whole. With an optimal degree of regeneration, the consumption reaches a value of 98 kg/s (Fig. 8).

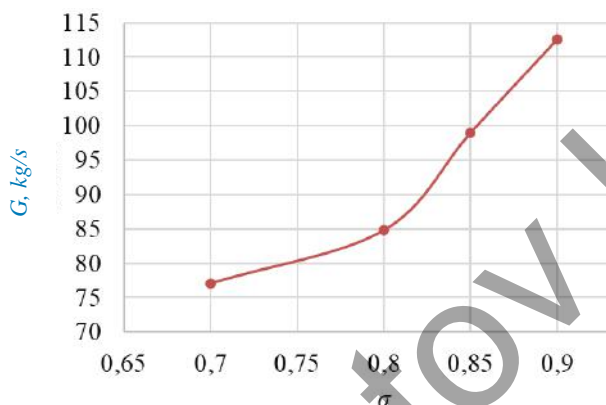

**Fig.8.** Dependence of the coolant flow rate on the degree of regeneration

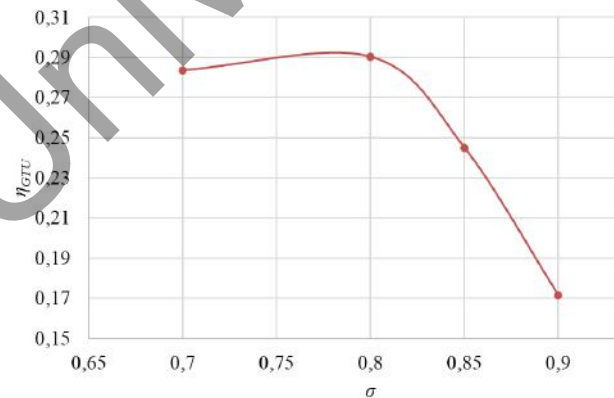

**Fig.9.** Dependence of the efficiency of the GTU of the real cycle on the degree of regeneration

### 4. Conclusion

Summing up the work done, it should be noted that the purpose of the study has been achieved. 2 series of design calculations were carried out for the regenerator and the GTU circuit. The highest efficiency turned out to be equal to 29% with a degree of regeneration of 0.8, while the resistance along two pressure paths was 0.03 MPa at a coolant velocity of 5 m/s. As the resistance  $\Delta P$  increases, the heating in the reactor and regenerator decreases, which is associated with a deterioration in the heat exchange process due to energy losses to overcome the resistance. The efficiency of the unit has a maximum with a degree of regeneration of 0.9 – which is the boundary value. With higher degrees of regeneration, we have large dimensions of the regenerator and high resistance values, which negatively affects the investment and efficiency of the device. The decisions made in the development of the power unit are justified: the parameter level is the temperature of the coolant  $T_c=530^{\circ}\text{C}$ ,  $T_p=950^{\circ}\text{C}$  and the working fluid  $T_c=850^{\circ}\text{C}$ ,  $p_c=6.81$  MPa, taking into account the process of high-temperature electrolysis  $T_p=800^{\circ}\text{C}$ . The optimal controlled parameters of the thermal circuit have been established:  $\varepsilon=2.4$  (degree of pressure increase in the compressor),  $\sigma=0.8-0.9$  (degree of regeneration). An analysis of the effect of the degree of regeneration on the resistance of the regenerator was carried out, during which a hyperbolic dependence  $\zeta=f(\sigma)$  was obtained.

**Conflict of interest statement**

The authors declare that they have no conflict of interest in relation to this research, whether financial, personal, authorship or otherwise, that could affect the research and its results presented in this paper.

**CRedit author statement**

**Nurym K.A.:** Investigation, Modeling; **Antonova A.M.:** Supervision; Conceptualization, Methodology; **Sakipov K.E.:** Formal analysis, Review & Editing; **Vorobyev A.V.:** Data Curation, Writing - Original Draft; **Stetsov N.V.:** Calculations, Visualization. The final manuscript was read and approved by all authors.

**References**

- 1 McDonald C.F. (2012) Helium turbomachinery operating experience from gas turbine power plants and test facilities. *Applied Thermal Engineering*, 44(2), 108–142. <https://doi.org/10.1016/j.applthermaleng.2012.02.041>
- 2 Fruttschi H.U. (2005) Closed-Cycle Gas Turbines: Operating Experience and Future Potential. ASME Press, 294. <https://doi.org/10.1115/1.802264>
- 3 Bisio G., Massardo A., Agazzani A. (1996) Combined Helium and Combustion Gas Turbine Plant Exploiting Liquid Hydrogen (LH<sub>2</sub>) Physical Exergy. *J. Eng. Gas Turbines Power.*, 118(2), 257 – 264. <https://doi.org/10.1115/1.2816586>
- 4 Kupecki J., Hercog J., Motyliński K., Malesa J., Muszyński D., Skrzypek E., Skrzypek M., Boettcher A., Tchorek G. (2024) Advancing production of hydrogen using nuclear cycles – integration of high temperature gas-cooled reactors (HTGR) with solid oxide electrolyzers (SOE). *International Journal of Hydrogen Energy*, 53, 40 – 48. <https://doi.org/10.1016/j.ijhydene.2023.12.017>
- 5 Gelfenbein L.G. (1963) Regenerators of gas turbine units. Moscow, 180. Available at: [www.gornitsa.ru/item.php?id=15544612](http://www.gornitsa.ru/item.php?id=15544612) [in Russian]
- 6 Kostyuk A.G., Frolov V.V., Bulkin A.E., Trukhny A.D. (2016) *Steam and gas turbines for power plants textbook for universities*. Moscow, Publ.House of MEI, 556. Available at: <https://obuchalka.org/2017111297430/parovie-i-gazovie-turbini-dlya-elektrostantsii-kostuk-a-g-frolov-v-v-bulkin-a-e-trukhny-a-d-2016.html> [in Russian]
- 7 Grebennik V.N., Kukharkin N.E., Ponomarev-Stepnoy N.N. (2008) High-temperature gas-cooled reactors - an innovative direction in the development of nuclear energy. Energoatomizdat, 136. Available at: <https://cyberleninka.ru/article/n/vysokotemperaturnye-gazoolzhzhaemye-reaktory/viewer> [in Russian]
- 8 Goryunova I.Y., Larionov I.D. (2017) GTU regenerators: a methodological manual. Yekaterinburg : Ural University Publishing House, 80. Available at: <http://elar.urfu.ru/handle/10995/54034> [in Russian]
- 9 Lipin A.A., Romanenko Yu.E., Shibashov A.V., Lipin A.G. - Calculation of heat exchangers. Shell-and-tube heat exchangers. Ivanovo, 76. Available at: <https://e.lanbook.com/book/171826> [in Russian]
- 10 Stetsov N.V. (2023) Effect of changing the regenerator resistance on the characteristics of a closed nuclear gas turbine with a hydrogen complex. *Butakovskie readings: articles collection of the III All-Russian youth conference with international participation*, Tomsk: TPU Publishing House, 249 – 252. Available at: <http://earchive.tpu.ru/handle/11683/77631>
- 11 Stetsov N.V. (2023) Analysis of the influence of controlled parameters on the operation of a closed GTU with a hydrogen complex. *Butakovskie readings: articles collection of the III All-Russian youth conference with international participation*, Tomsk: TPU Publishing House, 427 – 430. Available at: <http://earchive.tpu.ru/handle/11683/76052> [in Russian]
- 12 Antonova A.M., Vorobyev A.V., Stetsov N.V. (2022) Analysis of the influence of controlled parameters on the efficiency of a closed GTU with a hydrogen complex. *Proceedings of the XIII All-Russian Scientific and Technical Conference*, Orenburg State University, 51 - 57. Available at: <https://www.elibrary.ru/item.asp?id=50174542&ppf=1>
- 13 Guidance document on standardization rules for thermal and hydraulic calculation of heat exchange equipment of NPP OKSTU 3103 (1990) Available at: <https://docs.cntd.ru/document/1200085786> [in Russian]

**AUTHOR'S INFORMATION**

**Nurym K.A.** - PhD student, Department of Thermal Power Engineering, L.N. Gumilyov Eurasian National University, Astana, Kazakhstan; <https://orcid.org/0000-0003-3822-5697>; [kazedu23@gmail.com](mailto:kazedu23@gmail.com)

**Antonova A.M.** – Candidate of Techn. Sciences, Associate Professor, Butakov research center, Tomsk Polytechnic University, Tomsk, Russia; SCOPUS Author ID: 56950262800; <https://orcid.org/0000-0002-5230-9750>; [anton@tpu.ru](mailto:anton@tpu.ru)

**Sakipov K.E.** — Candidate of Techn. Sciences, Associate Professor, Power Engineering Department, L.N. Gumilyov Eurasian National University, Astana, Kazakhstan; <https://orcid.org/0000-0003-2477-3879>; [sakamer2100@gmail.com](mailto:sakamer2100@gmail.com).

**Vorobyev A.V.** – Candidate of Techn. Sciences, Associate Professor, Butakov research center, Tomsk Polytechnic University, Tomsk, Russia; SCOPUS Author ID 56950140400; <https://orcid.org/0000-0003-4149-0387>; [worob@tpu.ru](mailto:worob@tpu.ru).

**Stetsov N.V.**– Student of Butakov's research center, Tomsk Polytechnic University, Tomsk, Russia; <https://orcid.org/0009-0006-7968-9403>; [nikolay.stecov@mail.ru](mailto:nikolay.stecov@mail.ru)