

A.E. Goldstein[✉], K.A. Stryapchev*National Research Tomsk Polytechnic University, Tomsk, Russia*

Measurement of ferromagnetic pipe wall thickness by magnetic flux leakage method

The paper considers the use of the magnetic flux leakage method for measuring the wall thickness of ferromagnetic pipes. The method implies longitudinal magnetization of the test pipe section using a short solenoid and measurement of the spatial longitudinal component of the magnetic field strength in the air gap between the solenoid and the test pipe using Hall sensors. A numerical model has been developed to analyze the interaction between the magnetizing field of the short solenoid and the ferromagnetic pipe. The model considers the nonlinear magnetic properties of the test pipe and its geometrical parameters, including the distance between the pipe edge and the measurement plane of magnetic field. The accuracy of the model was validated through physical modeling techniques. A simplified analytical dependence of the longitudinal component of the magnetic field strength on the pipe wall thickness was obtained. A method was proposed to mitigate the impact of the distance from the measurement plane to the pipe edge on wall thickness measurement results. The method entails simultaneous measurement of the magnetic field strength and the distance between the pipe edge and the measurement plane. The method considers the distance between the pipe edge and the measurement plane of the magnetic field strength thereby enabling a 10-fold reduction in the error of the wall thickness measurement induced by the edge effect. The study results can be used for generation, mathematical modeling, and measurement of the magnetic field, including magnetic inspection of steel drill pipes.

Keywords: magnetic testing, magnetic flux leakage method, finite element method, analytical model, Hall sensor

[✉]*Corresponding author:* Goldstein Alexander, algol@tpu.ru

Introduction

Magnetic flux leakage (MFL) has been the most widely used non-destructive testing method for pipes made of ferromagnetic materials [1–4].

According to the MFL method, a pipe section is magnetized along its longitude direction in a constant magnetic field. The main part of the magnetic flux generated by the magnetic field source is closed along the pipe body. A small part of this flux is closed in the air above the pipe, in line with the ratio of magnetic conductivity of the ferromagnetic material and air. The latter is referred to as the magnetic leakage flux.

Given the constant total magnetic flux, a decrease in the pipe cross-sectional area leads to a redistribution of the specified magnetic fluxes: a decrease in the magnetic flux along the pipe body and an increase in the magnetic flux through the air. Consequently, measuring the magnetic flux density in the air (magnetic leakage flux) provides data on the cross-sectional area of a metal object.

In addition, the presence of continuity defects within the pipe leads to the distortion of magnetic field lines, causing a portion of the magnetic flux passing through the metal to leak onto the pipe's surface, thereby forming a local magnetic leakage flux. The disturbance of the magnetic flux depends on dimensions and configuration of the defect, the depth of its location, and its orientation relative to the direction of the magnetizing field.

A comparable technical approach, employed to inspect drill pipes, is testing of steel ropes for the presence of unacceptable reduction in the cross-sectional area and local defects [5, 6].

Problem statement

When the MFL method is employed to measure the wall thickness of ferromagnetic pipes, the test object is magnetized by a constant longitudinal magnetic field generated by a short solenoid [7, 8] or by a magnetic system based on permanent magnets [1].

To measure the longitudinal component of the magnetic field strength (hereinafter magnetic field strength), Hall sensors, which are universally employed, are placed in the middle part of the magnetizing de-

vice in the air gap between the magnetizing device and the test object [4]. The number and location of Hall sensors are chosen to overlap the sensitivity zones of adjacent sensors and minimize the impact of test object's transverse displacements on measurement results.

The study attempted to analyze the efficacy of the MFL method for measuring the wall thickness of a ferromagnetic pipe. The study objectives were to develop a numerical model of the interaction between a constant magnetic field generated by a short solenoid and a ferromagnetic pipe, using the finite element method, experimentally verify the developed model, and find simplified analytical expressions to describe the pipe magnetic field and its dependence on the magnetizing device parameters, the pipe wall thickness, and the edge effect.

The geometry of the problem under consideration is depicted schematically in Figure 1.

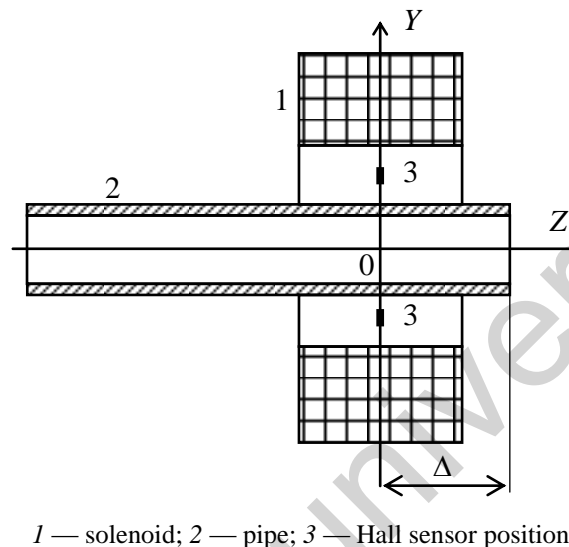

Figure 1. Ferromagnetic pipe in the magnetic field of the short solenoid

The test object was a section of the pipe fabricated of 15XM steel. Its outer diameter was 88.9 mm, a wall thickness was 6–12 mm, and a length was 2000 mm. The pipe was magnetized by a solenoid (135 mm in length, 340 mm in outer diameter, 230 mm in inner diameter), with a maximum magnetomotive force $Iw_1 = 8.4$ kA turns, where I denotes the solenoid current and w_1 represents the number of solenoid turns. The pipe and the solenoid were arranged coaxially.

Hall sensors 3 are arranged along the transverse symmetry plane of the solenoid, in the air gap between solenoid 1 and test pipe 2, at an equal distance from the pipe surface. During the pipe wall thickness measurement, at least four Hall sensors are used to minimize the dependence of the measurement result on transverse displacements of the test pipe. The sensors are positioned with an angular shift of 90° relative to the transverse symmetry plane.

During measurement, the test pipe moves in the longitudinal direction Z relative to the solenoid and Hall sensors. During its displacement, the longitudinal component of the magnetic field strength and the distance Δ between the pipe edge and the transverse symmetry plane of the solenoid are measured. The averaged value of the magnetic field measurement by Hall sensors is used as the value of the magnetic field strength H .

A change in the pipe cross-sectional area causes redistribution of magnetic fluxes along the pipe body and through the air. Measuring the magnetic field strength provides data on the cross-sectional area of the metal object, which is linearly related to the pipe wall thickness, T .

Numerical modeling results

A numerical model of interaction between the constant magnetic field generated by the short solenoid and the pipe was developed using the finite element method (FEM).

The benefits of FEM for modeling magnetic fields include arbitrary shape of the inspected area and its capacity to address asymmetric problems by taking into account the heterogeneity of material parameters and the media [9–12].

The model was constructed via the COMSOL Multiphysics software, using the MAGNETIC FIELDS module. The integrated tools of the software were used to construct a 3-D model pipe-inductor, with specified magnetic characteristics of the pipe and the parameters of the inductor, as well as the magnetization mode.

It was assumed in the modeling that the outer boundary of the study area is cylindrical in shape (Fig. 2). The magnetic properties of 15XM steel were set based on a basic magnetization curve experimentally obtained in accordance with GOST 8.377-80 [13].

Figure 3 shows equipotential lines and color spectrum indicating the distribution of magnetic induction B along the longitudinal axis of the pipe at a distance of 20 mm from its surface during interaction with the magnetic field of the solenoid with $Iw_1 = 8.4$ kA turns at a pipe wall thickness of 9.8 mm, which was obtained by numerical modeling. In this case, symmetrical positioning of the pipe relative to the transverse symmetry plane of the solenoid was considered.

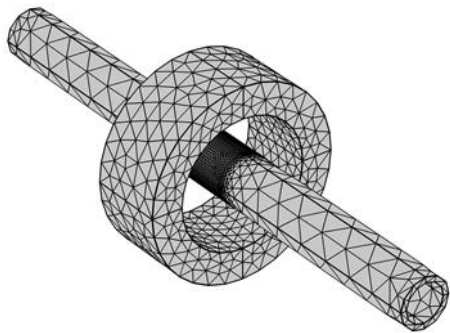

Figure 2. Calculation model after grid superimposition

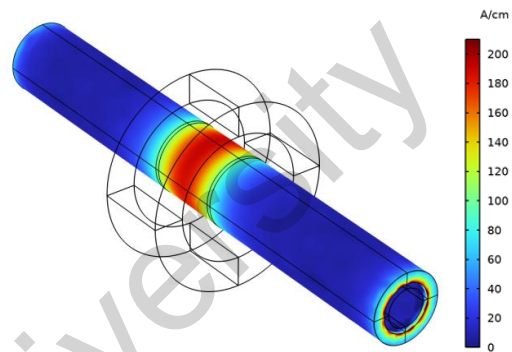

Figure 3. Magnetic induction distribution along the pipe length at a distance of 20 mm from its surface

The analysis of the magnetic field strength distribution along the longitudinal axis $H(Z)$ revealed its inhomogeneous character. A relatively homogeneous magnetic field is observed in the transverse symmetry plane of the solenoid. It extends in the longitudinal direction at a distance comparable to the longitudinal size of the solenoid. In this case, the value of the magnetic field strength H depends on the value of the magnetomotive force Iw_1 , geometrical parameters of the solenoid, magnetic properties of the pipe material, and the pipe wall thickness T .

Figure 4 shows the dependence of the magnetic field strength H in the transverse symmetry plane of the solenoid at a distance of 20 mm from the pipe surface on the value Iw_1 at a wall thickness of 9 mm (solid line) obtained based on the results of numerical simulation. The discrepancy between the calculated and experimental results (circle symbols) does not exceed 3 %, which is acceptable for most practical tasks.

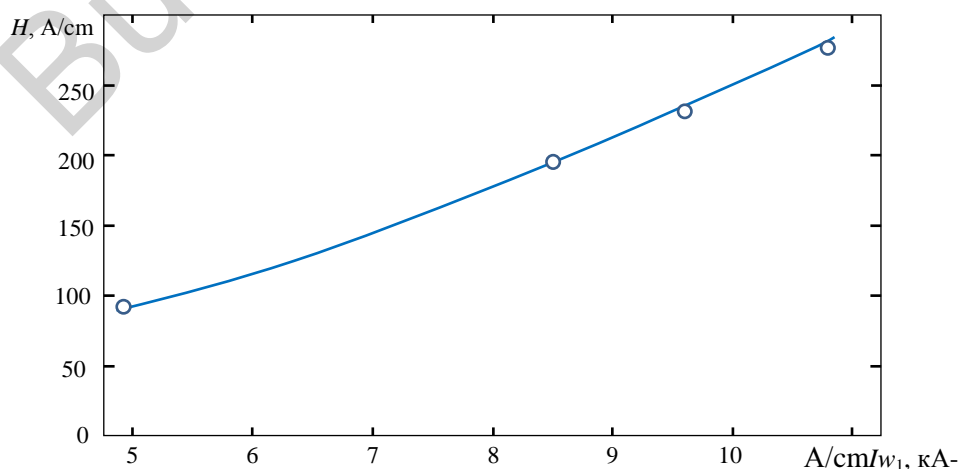

Figure 4. Dependence of the magnetic field strength in the transverse symmetry plane of the solenoid at a distance of 20 mm from the pipe surface on the value of Iw_1

Figure 5 shows the dependence of the magnetic field strength H on the pipe wall thickness T at a fixed value of the magnetomotive force $Iw_1 = 8.4$ kA-turns.

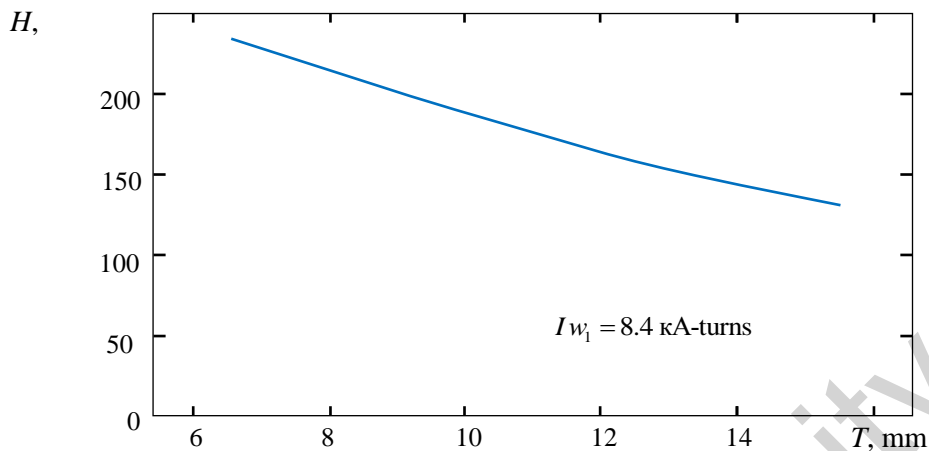

Figure 5. Dependence of the magnetic field strength on the pipe wall thickness

The analysis of this dependence reveals that the direct transformation function $H(T)$ remains constant within the specified range of test parameters $T = (6...12)$ mm. This indicates that the value of T can be determined based on the value of the measured magnetic field strength H . The dependence presented in Figure 5 can be approximated with high accuracy by a polynomial of the third degree:

$$H(T) = 381.003 - 27.145 T + 0.932 T^2 - 0.016 T^3.$$

The inverse transformation function $T(H)$ can also be approximated with high accuracy by a polynomial of the third degree:

$$T(H) = 33.179 - 0.185 H + 3.955 \times 10^{-4} H^2 - 3.628 \times 10^{-7} H^3.$$

The magnetic field strength H in the gap depends not only on the pipe wall thickness T , but to a large extent on the distance from the plane (transverse symmetry plane of the solenoid) to the pipe edge.

Figure 6 shows the dependence of the longitudinal spatial component of the magnetic field strength H on the distance Δ between the pipe edge and the transverse symmetry plane of the solenoid.

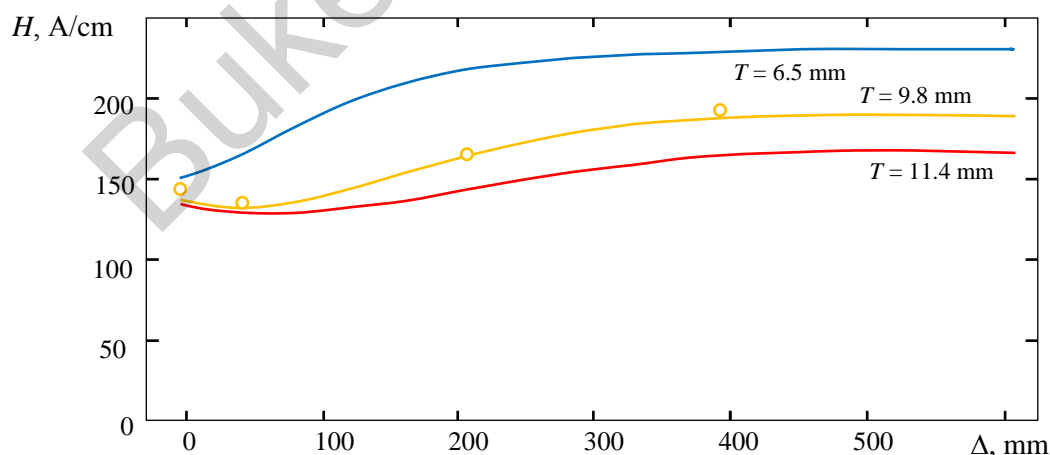

Figure 6. Dependence of the magnetic field strength on the distance from the transverse symmetry plane of the solenoid to the pipe end at different values of T

The analysis of this dependence shows that at the pipe length $L \geq 1.5$ m the magnetic field strength H remains constant in the middle part of the pipe with the constant wall thickness T . When approaching the

pipe edge, the magnetic field strength H decreases significantly. The edge effect is due to the change in the spatial distribution of the magnetic flux when the pipe edge is located close to the magnetized pipe section.

This effect can be mitigated by measuring the magnetic field strength H , as well as the distance Δ between the pipe edge and the transverse symmetry plane of the solenoid. A conventional distance sensor or a distance sensor as part of an electromechanical actuator that moves the test object can be used for measurement. Data on the linear displacement of the test object enable the correction of the wall thickness measurement results that accounts for the edge effect.

Figure 6 (circle symbols) illustrates the experimental dependence of the magnetic field strength on the distance between the pipe end and the transverse symmetry plane of the solenoid at $T = 9.8$ mm. The discrepancy between the calculated and experimental results does not exceed 3.5 %, which indicates that the experimental data correspond to the results of numerical modeling, which is acceptable for most practical tasks.

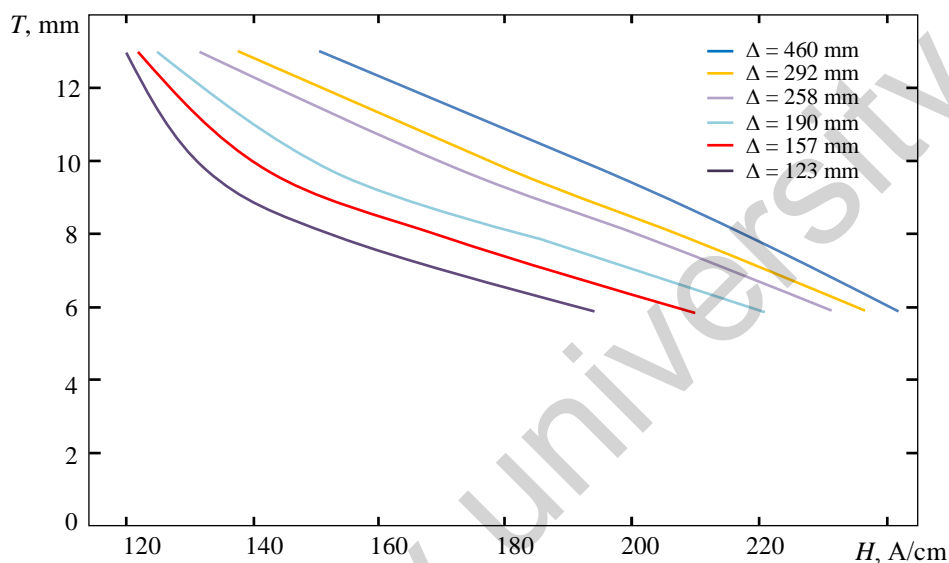

Figure 7. Functions of the inverse transformation of the value of the longitudinal spatial component of the magnetic field strength H into the thickness T of the pipe wall for different distances Δ between the end of the pipe and the transverse plane of symmetry of the solenoid

Figure 7 shows a set of functions of the inverse transformation of the longitudinal spatial component of the magnetic field strength H into the pipe wall thickness T for different distances Δ between the pipe edge and the transverse symmetry plane of the solenoid. A group of pipe specimens with different wall thickness T is used to determine these functions. The magnetic field strength H is measured for fixed values of the distance Δ between the pipe edge and the transverse symmetry plane of the solenoid. Functions $T(H)$ with acceptable accuracy can be obtained by standard approximation of the experimental data by third degree polynomials. For measurement, the value of the test parameter $T(H)$ is calculated for a specific distance Δ .

Conclusion

The effectiveness of the proposed method for measuring ferromagnetic pipe wall thickness was confirmed by the results of laboratory tests performed with a prototype used to measure the thickness of the pipe wall with the specified parameters. A total of 7 test pipes with the wall thickness T within the specified range were used to define the transform functions.

The experimental results showed that the change in the magnetic field strength induced by the edge effect can attain 30 % for the specified geometrical parameters of the test object. Without corrections for the edge effect, the relative measurement error of the wall thickness T can reach 40 %. The length of the edge effect zone is about 500 mm for each of the pipe edges.

The proposed method accounts for the distance between the pipe edge and the solenoid plane and enables 10-fold reduction in the wall thickness error from the edge effect. In this case, the length of untested areas of the test object, where the edge effect mitigation is ineffective, is less than 125 mm.

References

- 1 Christie R. Monitoring and Managing Coiled Tubing Integrity / R. Christie, Ch. Liu, R. Stanley, M. Torregrossa, E. Zheng, L. Zsolt // *Oilfield Review*. — 2015. — Vol. 27, No. 1. — P. 48–56.
- 2 Потапов А.И. Электромагнитные и магнитные методы неразрушающего контроля материалов и изделий. Научное справочно-методическое пособие [в 2 т.]: Т. 2: Электромагнитные и магнитные методы дефектоскопии и контроля свойств материалов / А.И. Потапов, В.А. Сясько, П.В. Соломенчук. — СПб.: Нестор-История, 2015. — 440 с.
- 3 Slesarev D.A. Data processing and representation in the MFL method for nondestructive testing / D.A. Slesarev, A.A. Abakumov // *Russian Journal of Nondestructive Testing*. — 2013. — Vol. 49, No. 9. — P. 3–9.
- 4 Шаранова Д.А. Бесконтактные методы выявления питтинговых дефектов стенок металлических изделий / Д.А. Шаранова // *Территория «НЕФТЕГАЗ»*. — 2016. — № 10. — С. 34–40.
- 5 Промышленная безопасность при эксплуатации грузоподъемных кранов: Сборник документов. Серия 10. Выпуск 7. — 2-е изд., испр. — М.: Научно-технический центр «Промышленная безопасность», 2009. — 288 с.
- 6 Slesarev D. Magnetic and electromagnetic testing of suspension cables of bridges and structures / D. Slesarev, A. Semenov // *Lecture Notes in Civil Engineering*. — 2022. — Vol. 200. — P. 805–810.
- 7 Установка неразрушающего контроля бурильных труб магнитным методом в мобильном исполнении «Магпорт-бур 1.2». Руководство по эксплуатации. СПб., 2016. — 20 с.
- 8 The ARTIS-3 Portable EMI Pipe Inspection System. — [Electronic resource]. — Access mode: <https://oem-usa.com/a3port/> (Date of request: 10.02.2025).
- 9 Potapov A.I. Optimization of the parameters of primary measuring transducers that use the MFL technology / A.I. Potapov, V.A. Syas'ko, O.P. Pudovkin // *Russian Journal of Nondestructive Testing*. — 2013. — Vol. 51, No. 8. — P. 64–71.
- 10 Aikeyeva A.A. Modeling electromagnetic systems / A.A. Aikeyeva, B.A. Zhautikov, A.M. Aidarkhanov, A.S. Zhanasbayeva, F.B. Zhautikov, A.S. Belgibayev // *Bulletin of the University of Karaganda – Physics*. — 2014. — No. 3(75). — P. 28–34.
- 11 Goldshtein A.E. Modeling of magnetic fields and signals of a ferromagnetic pipe flaw detector induced by a through hole defect / A.E. Goldshtein, V.Y. Belyankov // *Bulletin of the University of Karaganda – Physics*. — 2020. — No. 4(100). — P. 49–56.
- 12 Dyusembaeva A.N. Optimal choice of the geometric shape rotor blade wind turbine using the numerical method / A.N. Dyusembaeva, N.K. Tanasheva, T.Zh. Tleubergenova, A.R. Bakhtybekova, Zh.B. Kutumova, A.R. Tussuphanova, N.T. Abdirova // *Bulletin of the University of Karaganda – Physics*. — 2020. — No. 2(114). — P. 53–62.
- 13 ГОСТ 8.377-80 «Материалы магнитомягкие. Методика выполнения измерений при определении статических магнитных характеристик» М.: Издательство стандартов, 1980. — 26 с.

А.Е. Гольдштейн, К.А. Стряпчев

Магниттік ағынның шашырау әдісімен ферромагниттік құбыр қабырғасының қалыңдығын магниттік бақылау

Мақалада ферромагниттік құбырлардың қабырғасының қалыңдығын бақылау үшін магнит ағынының шашырау әдісін қолдану қарастырылған, ол бақыланатын құбыр учаскесінің қысқа соленоиды арқылы бойлық магниттелуіне және электромагниттік құбыр мен бақыланатын Холл датчигі арасындағы ауа саңылауындағы магнит өрісінің кернеулігінің бойлық кеңістік құраушысын өлшеуге негізделген. Сынақ объектісінің сызықты емес магниттік қасиеттерін және оның геометриялық параметрлерін, оның ішінде түтіктің жиегі мен магнит өрісінің кернеулігін өлшеу жазықтығы арасындағы қашықтықты ескере отырып, қысқа соленоидтың магниттеу өрісінің ферромагниттік түтікпен өзара әрекеттесуінің сандық моделі әзірленді. Сандық модельдің дұрыстығы физикалық модельдеу нәтижелерімен расталады. Магнит өрісінің кернеулігінің бойлық құрамдас бөлігінің құбыр қабырғасының қалыңдығына оңайлатылған аналитикалық тәуелділігі алынады. Магнит өрісінің кернеу мәнін және өлшеу жазықтығынан құбырдың шетіне дейінгі қашықтықты бірлесіп өлшеуге негізделген өлшеу жазықтығынан құбырдың шетіне дейінгі қашықтық қабырғасының қалыңдығын бақылау нәтижелеріне әсерін азайту әдісі ұсынылған. Ұсынылған бақылау әдісін қолданған кезде, құбырдың жиегі мен магнит өрісінің кернеулігін өлшеу жазықтығы арасындағы қашықтықты ескере отырып, жиек әсеріне байланысты қабырға қалыңдығын өлшеу қателігін шамамен 10 есе азайтуға болады. Мақалада келтірілген нәтижелер магнит өрістерін құру, математикалық модельдеу және өлшеу есептерін шешуде, соның ішінде болат бұрғылау құбырларын магниттік бақылау үшін пайдаланылуы мүмкін.

Кілт сөздер: магниттік бақылау, магнит ағынының ағу әдісі, соңғы элементтер әдісі, аналитикалық модель, Холл датчигі

А.Е. Гольдштейн, К.А. Стряпчев

Магнитный контроль толщины стенки ферромагнитных труб методом рассеяния магнитного потока

Рассмотрено использование метода рассеяния магнитного потока для контроля толщины стенки ферромагнитных труб, основанного на продольном намагничивании с помощью короткого соленоида участка контролируемой трубы и измерении продольной пространственной составляющей напряженности магнитного поля в воздушном промежутке между соленоидом и контролируемой трубой с помощью датчиков Холла. Разработана численная модель взаимодействия намагничивающего поля короткого соленоида с ферромагнитной трубой, учитывающая нелинейные магнитные свойства объекта контроля и его геометрические параметры, в том числе, расстояние между краем трубы и плоскостью измерения напряженности магнитного поля. Корректность численной модели подтверждена результатами физического моделирования. Получена упрощенная аналитическая зависимость продольной составляющей напряженности магнитного поля от толщины стенки трубы. Предложен метод уменьшения влияния на результаты контроля толщины стенки расстояния от плоскости измерения до края трубы, основанный на совместном измерении значения напряженности магнитного поля и расстояния от плоскости измерения до края трубы. При использовании предлагаемого метода контроля благодаря учету расстояния между краем трубы и плоскостью измерения напряженности магнитного поля погрешность измерения толщины стенки, обусловленная краевым эффектом, может быть снижена примерно в 10 раз. Результаты, представленные в статье, могут быть использованы при решении задач создания, математического моделирования и измерения магнитных полей, в том числе для магнитного контроля стальных буровых труб.

Ключевые слова: магнитный контроль, метод рассеяния магнитного потока, метод конечных элементов, аналитическая модель, датчик Холла

References

- Christie, R., Liu, Ch., Stanley, R., Torregrossa, M., Zheng, E., & Zsolt, L. (2015). Monitoring and Managing Coiled Tubing Integrity. *Oilfield Review*, 27(1), 48–56.
- Potapov, A.I., Syasko, V.A., & Solomenchuk, P.V. (2015). *Elektromagnitnye i magnitnye metody nerazrushaiushchego kontrolya materialov i izdelii. Elektromagnitnye i magnitnye metody defektoskopii i kontrolya svoystv materialov [Electromagnetic and magnetic methods of non-destructive testing of materials and products. Electromagnetic and magnetic methods of defectoscopy and control of material properties]*. (Vols 1–2; Vol. 1). St. Petersburg: Nestor-Istoriia [in Russian].
- Slesarev, D.A., & Abakumov, A.A. (2013). Data processing and representation in the MFL method for nondestructive testing. *Russian Journal of Nondestructive Testing*, 49(9), 3–9.
- Sharanova, D.A. (2016). Beskontaktnye metody vyivleniia pittingovykh defektov stenok metallicheskiikh izdelii [Non-contact methods for detecting pitting defects in the walls of metal products]. *Territoriia «NEFTEGAS» — Territory of «NEFTEGAZ»*, 10, 34–40 [in Russian].
- (2009). *Promyshlennaia bezopasnost pri ekspluatatsii gruzopodemnykh kranov [Industrial safety during operation of overhead cranes]*. Collection of documents. Series 10. Issue 7. Moscow: Nauchno-tekhnicheskii tsentr «Promyshlennaia bezopasnost» [in Russian].
- Slesarev, D., & Semenov, A. (2022). Magnetic and electromagnetic testing of suspension cables of bridges and structures. *Lecture Notes in Civil Engineering*, 200, 805–810.
- (2016). *Ustanovka nerazrushaiushchego kontrolya burilnykh trub magnitnym metodom v mobilnom ispolnenii «Magportabur 1.2». Rukovodstvo po ekspluatatsii [NDT installation for drill pipes by the magnetic method in the mobile version «Magportabur 1.2». Manual]*. St. Petersburg [in Russian].
- (2025). The ARTIS-3 Portable EMI Pipe Inspection System. Retrieved from <https://oem-usa.com/a3port/>
- Potapov, A.I., Syasko, V.A., & Pudovkin, O.P. (2013). Optimization of the parameters of primary measuring transducers that use the MFL technology. *Russian Journal of Nondestructive Testing*, 51(8), 64–71.
- Aikeyeva, A.A., Zhautikov, B.A., Aidarkhanov, A.M., Zhanasbayeva, A.S., Zhautikov, F.B., & Belgibayev, A.S. (2014). Modeling electromagnetic systems. *Bulletin of the University of Karaganda – Physics*, 3(75), 28–34.
- Goldshtein, A.E., & Belyankov, V.Y. (2020). Modeling of magnetic fields and signals of a ferromagnetic pipe flaw detector induced by a through hole defect. *Bulletin of the University of Karaganda – Physics*, 4(100), 49–56.
- Dyusembaeva, A.N., Tanasheva, N.K., Tleubergenova, A.Zh., Bakhtybekova, A.R., Kutumova, Zh.B., Tussuphanova, A.R., & Abdirova, N.T. (2020). Optimal choice of the geometric shape rotor blade wind turbine using the numerical method. *Bulletin of the University of Karaganda – Physics*, 2(114), 53–62.
- (1980). GOST 8.377-80 «Materialy magnitomiagkie. Metodika vypolneniia izmerenii pri opredelenii staticheskikh magnitnykh kharakteristik» [Soft magnetic materials. Methodology for performing measurements when determining static magnetic characteristics]. Moscow: Izdatelstvo standartov [in Russian].

Information about the authors

Goldstein, Alexander (*corresponding author*) — Doctor of Technical Sciences, Professor, National Research Tomsk Polytechnic University, Tomsk, Russia; e-mail: algol@tpu.ru; ORCID ID: <https://orcid.org/0009-0001-7057-7310>

Stryapchev, Kirill — PhD student, National Research Tomsk Polytechnic University, Tomsk, Russia; e-mail: inscrut@yandex.ru; ORCID ID: <https://orcid.org/0009-0007-3935-5721>

Букетов университет