

PAPER • OPEN ACCESS

## Analyzers of charged particles flows with different functional capabilities

To cite this article: A O Saulebekov and Zh T Kambarova 2017 *IOP Conf. Ser.: Mater. Sci. Eng.* **168** 012084

View the [article online](#) for updates and enhancements.

### Related content

- [Skin Photoaging: Radiofrequency technology](#)  
R Yin, Q Chen and M R Hamblin
- [High-resolving electrostatic charged particles energy analyzer with fine tuning for space investigations](#)  
A M Ilyin and I A Ilyina
- [STUDY OF EXOTIC WEAKLY BOUND NUCLEI USING MAGNETIC ANALYZER MAVR](#)  
V.A. Maslov, V.I. Kazacha, I.V. Kolesov et al.

Репозиторий КарНУ

# Analyzers of charged particles flows with different functional capabilities

A O Saulebekov<sup>1</sup> and Zh T Kambarova<sup>2</sup>

<sup>1</sup> Lomonosov Moscow State University, Kazakhstan branch, Kazhimukan str.11, Astana 010010, Kazakhstan

<sup>2</sup>Ye.A. Buketov Karaganda State University, Universitetskaya str. 28, Karaganda 100028, Kazakhstan

E-mail: saulebekov@mail.ru

**Abstract.** Parameters of instruments developed on the basis of previously calculated different electron-optical systems for the analysis of charged particle flows were considered in the present work. Recommendations for their application in various fields of electron spectroscopy for the analysis of a solid surface were given.

## 1. Introduction

Classical cylindrical and spherical electrostatic mirrors and their possibilities are sufficiently well understood. However, the variable combinations at additional conditions open new functional capabilities of these devices. In the work it has been proposed the instruments, in which this approach was used. For example, the focal surface of the cylindrical energy analyzer of charged particles has a complex shape, which makes it impossible to use it in the spectrograph mode. It is overcome by imposing the conditions of straightening of the foci line.

## 2. Construction of Auger spectrometer for the analysis of very rough surface of a solid

In the base of developing is the idea of an Auger spectrometer creation, that being mounted on a standard flange DU-200 can be connected to ultrahigh-vacuum equipments for researches or technological needs.

For microanalysis of very rough surface of solid the system shown in Fig.1 can be used. The distinctive features of this system are the second-order angular focusing of charged particle beam in combination with a high linear dispersion on energy and small coefficient of longitudinal magnification. The longitudinal displacement of the source in this case is of less impact on energy resolution than in the classical cylindrical mirror (CM) [1-2], that is, the settings on the focus in a large range of cavities depths and heights of projections of a rough surface (e.g., fracture surface) is kept. Furthermore, by significantly reducing the entrance angle (to  $10^0$ ), the depth of probed cavities increases several times in comparison with CM. For CM the entrance angle is  $42.3^0$ , i.e. depth of probed cavities approximately equal to their width. Increasing the depth of probing is shown in Fig.1 and is defined by the following formula

$$n = \frac{h_2}{h_1} = \frac{\tan 42.3^0}{\tan 10^0} = 5.16$$

Auger spectrometer for microprobing of very rough surfaces is shown in Fig.1. It consists of the side flange 1, on which all functional elements are collected, this flange is attached to the flange of the vacuum chamber 2; two cylindrical electrodes (inner 3 and outer 4); electrodes 5 for electrostatic protection of CM working field, the electron gun 6; outer 7 and inner 8 spherical electrodes [3]; exit aperture of diameter about 0.1-0.5 mm (typically used in spectrometers), receiver 9; sample 10, the investigated surface of which is perpendicular to CM axis and intersects it at the front focus; permalloy screen 11 for protection of analyzer from external electromagnetic fields; windows 12 for pass of charged particles beam through the inner cylindrical electrode that tightened by a one dimensional grid. The electron-optical characteristics of the given construction were calculated. The luminosity of energy analyzer is about 0.15% of  $4\pi$ , and the energy resolution - 0.02%.

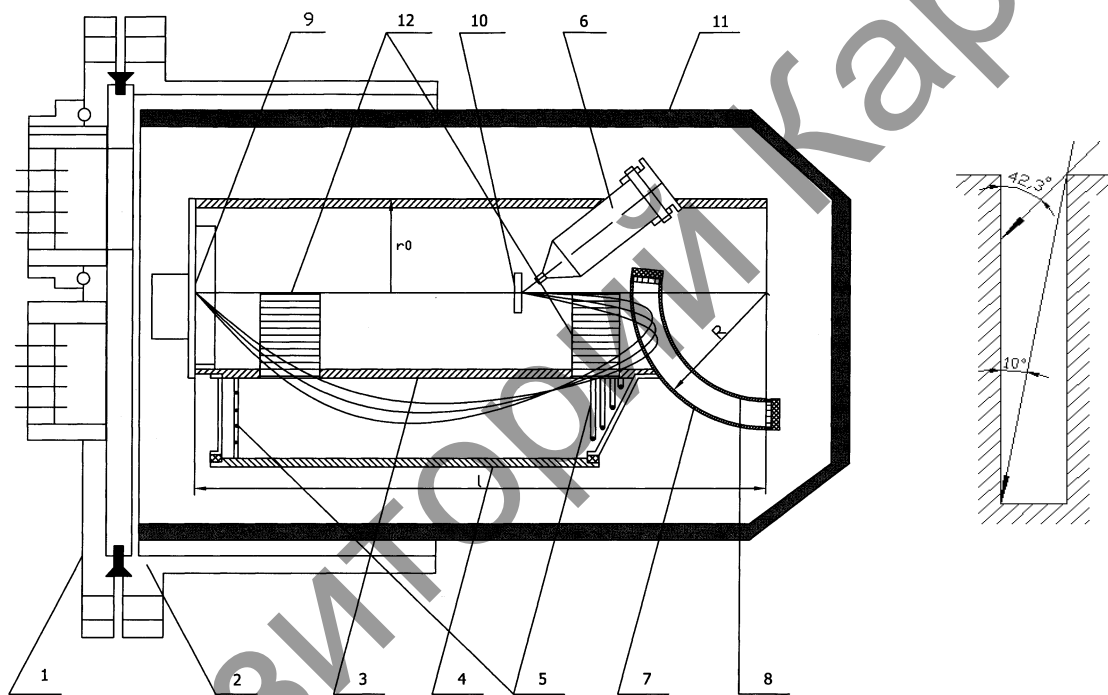
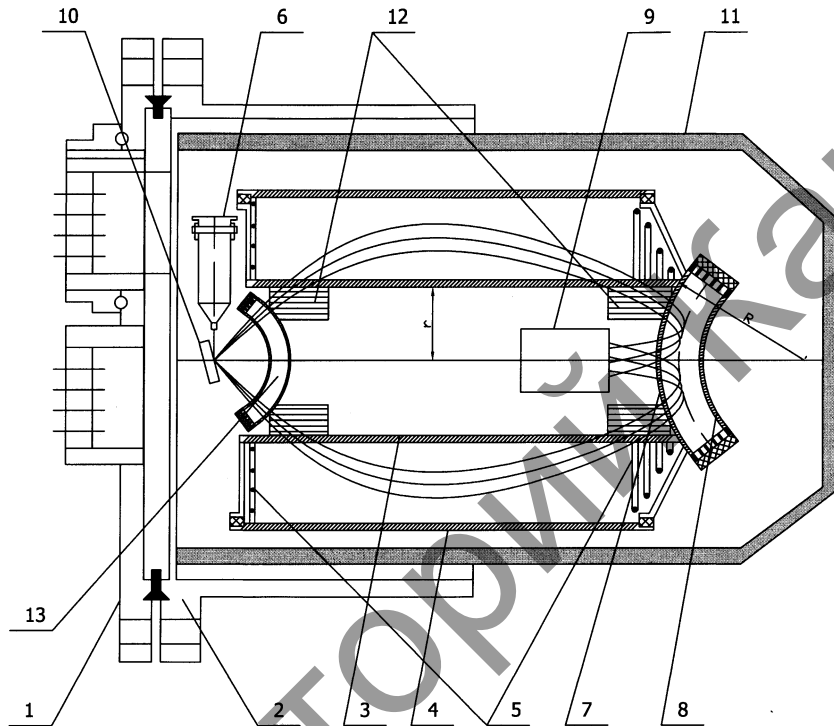

Figure 1. Auger spectrometer for the analysis of very rough surfaces.

### 3. Construction of the energy analyzer of the double filter type

Wide use of dispersionless electrostatic analyzers of double filter type is due to following properties. It is the reduced requirements to the angular focusing of the analyzed beam in the receiver area, which makes these devices less sensitive to disturbance electromagnetic fields and allows to work with sources of large sizes. Energy analyzer which works on the principle of double filter can be constructed on the basis of the scheme with the retro reflection of the charged particles beam. The design of the spectrometer is shown in Fig.2. Elements of construction (from 1 to 12) are the same as those of the Auger spectrometer for rough surfaces (Fig.1). The filter function of high-energy charged particles 13 performs a spherical field between two grids at the entrance of CM. At the pass of charged particles beam through the filter, the low-energy part of spectrum is cut off. After the beam enters CM it experiences the dispersing action of the cylindrical electrostatic field. The spherical mirror between two 7 and 8 electrodes (SM), performing the second filter [3], reflects charged particles with the energy from a small interval. This interval is adjacent to the low-energy edge of the spectrum separated by the first filter. As a result of two filters action, SM+CM+SM energy analyzer separates the narrow band of spectral interval.

In practice it is convenient that the axial trajectory of beam emerged from the SM field at the intersection point of a spherical electrode with symmetry axis. Fig.2 shows the scheme of the double filter, calculated for specific case. For the side trajectories with divergence of  $10^0$  values of maximum depth of penetration to field  $R_m$  are 0.84711 (+) and 0.84553 (-) respectively. Then  $\Delta R_m / R_m = 0.1907\%$  and  $|(\Delta E) / E| = 1.37\%$ . The luminosity of device is 6.1% of  $4\pi$ .



**Figure 2.** Construction of energy analyzer of double filter type.

#### 4. Construction of the spectrograph on the based spherical and two cylindrical mirrors

The scheme for an energy- and angle-resolved spectrograph which provides high-quality angular focusing of charged particles beams of various energies along the focal surface shaped as a right circular cone was presented in Ref. [4]. An energy analyzer has been composed of successively arranged electrostatic spherical mirror and the cascades of internal and external reflection of a charged particles beam in the CM. In such case simultaneous registration of the finite intervals of charged particle distribution in both energy and angle by means of a position-sensitive detector of a relatively simple conic form, repeating a focal surface, is possible in practice. Express energy- and angle-analysis of the photoelectrons is possible only by means of high-luminosity energy analyzers. This requirement is met by a few known devices, including ESA-22 electrostatic electron spectrometer [5].

Theoretically developed construction of the spectrograph was described in this section; the spectrograph provides focal line straightening and is able to significantly reduce the measurement time of energy distributions in electron spectroscopy. General view of the spectrograph is shown in Fig.3. It consists of three agreed on parameters of electrostatic spherical and two cylindrical mirrors. The base component of spectrograph is a middle cylindrical electrode 1, which can be made of the pipe of certain radius (usually 20-30 mm, wall thickness is 0.5 mm, grade of steel is 12Ch18N10T). In the frame of electrode 1 three windows 2, 3 and 4 are necessary to be made. The windows are tightened by one-dimensional grid of nichrome wires with thickness of 0.15 mm arranged along generatrices of

the cylinder 1 with steps of 1 mm. Work spaces of electrostatic fields are placed: a) between the outer 6 and inner 5 spherical electrodes; b) between area of middle cylindrical electrode 1 and the inner cylindrical electrode 8; c) between area of middle cylindrical electrode 1 and the outer semi-cylindrical electrode 7; d) side cheeks 9, 10.

Let's consider the description of SM, operating in the internal reflection mode of charged particles beam. SM is consisted of two concentric spherical segments. The inner electrode 5 has a radius equal to twice the radius of the middle cylindrical electrode. The radius of the outer electrode 6 is determined from  $s$  reflection parameter [1]. For example, in construction of two-cascade cylindrical spectrograph, middle cylindrical electrode was made of a pipe of 21 mm radius. In this case, the inner spherical electrode will have radius of 42 mm, radius of outer electrode determined from the following formula

$$R_{outer} = \frac{R_{inner}}{1 - \frac{qu}{2Es}}$$

where  $q$  is the charge of analyzed particles,  $u$  is retarding potential difference between SM electrodes,  $E$  is kinetic energy of analyzed particles,  $R_{outer}$  and  $R_{inner}$  are radii of inner and outer spherical electrodes.

The inner electrode is usually pressed out of sheet of stainless steel with thickness of 0.5 mm, and is at ground potential, the outer electrode is carved and at retarding potential  $U_1$ . The inner electrode is provided with aperture windows 11 through which the charged particle beam enters the area of deflection spherical field and exits from it.

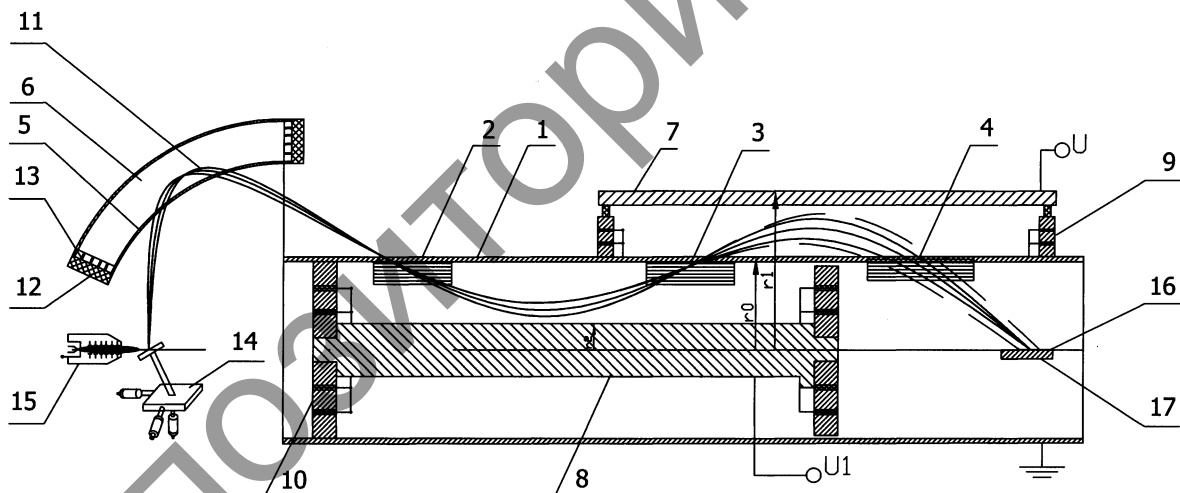

**Figure 3.** Construction of spectrograph on the based spherical and two cylindrical mirrors.

Windows are the slits in the form of a spherical zone disclosed by  $180^\circ$  in the azimuth angle. Each slit is covered by a one-dimensional grid of thin metal wires of 0.3 mm thickness in the form of circular arcs. Their radii equal to the radius of the inner spherical electrode. Wires are arranged at regular azimuthally interval in  $2^\circ$  in meridional planes, converging on the symmetry axis. As it is known, the transmission of the analyzer is defined as the ratio of intensity of the recorded charged particles flow and intensity of the monoenergetic flow entering analyzer. The scattering effect of the aperture grid for SM affects mainly to transmission of analyzer. At the same time focusing properties of SM are deteriorating insignificantly.

Spherical electrodes are centered by washers 12 made of an insulator, on which thin rings 13 are coaxially located. Potentials on the rings are distributed in accordance with the law  $1/R$  in order to avoid the influence of the fringe field on the area of the charged particles beam pass. The sample 14 is

fixed on the manipulator 15, allowed to move it in three mutually perpendicular directions with accuracy to 0.01 mm.

Let's now consider a cylindrical part of analyzer. 7, 8, 9 and 10 details are recommended for the construction from duralumin of D16T grade. The cylindrical electrodes 7 and 8 are supplied by  $U_1$  and  $U_2$  retarding potentials. On the sides cheeks 9 and 10 there are two protective ring electrodes which are at a potential in accordance with a logarithmic law of change of the cylindrical field from the radius. The value of the surface radius of the inner cylindrical electrode is selected based on requirements of equality deflecting potentials in cascades.

At the exit of analyzer, a plane diaphragm 16 with a rectilinear narrow are placed, its middle line coincides with symmetry axis of analyzer. Position-sensitive detector 17 in the form of a half-cylinder is located behind receiving aperture. Analyzer for protection from the influence of external electromagnetic fields was closed by a permalloy screen, which is not shown in Fig.3.

The value of luminosity of the spectrograph is about 1.7% of  $4\pi$ , energy resolution of about 0.1%.

## 5. Conclusions

Schemes of devices and their geometrical and electron-optical parameters were shown. Ways of protection from the effect of fringe fields were listed. Devices can be used in fields such as electronic microprobe spectroscopy, photoelectron spectroscopy, Auger spectroscopy with increased scanning area, photoelectron spectroscopy with energy-angular resolution, Auger electron spectroscopy of rough surfaces of solid.

## Acknowledgements

This work was supported by the grant GF4-0815 of the Ministry of Education and Science of the Republic of Kazakhstan.

## References

- [1] Trubitsyn A A 1995 A cylindrical mirror analyzer with high energy resolution *J. of Electron Spectroscopy and Rel. Phen.* **73** 305 – 310
- [2] Zashkvara V V and Ashimbaeva B U 1998 Cylindrical mirror analyzer with adjustable angular focusing *J. of Electron Spectroscopy and Rel. Phen.* **94** 89 – 96
- [3] Zashkvara V V, Saulebekov A O and oth. 1992 Electron-optical properties of electrostatic spherical mirror and systems based on it *Zh. Tech. Phys.* **62(6)** 189-204 [in Russian]
- [4] Zashkvara V V and Ashimbaeva B U 1994 Theoretical basis for the scheme of an electrostatic energy and angle-resolved spectrograph *Nucl. Instr. and Meth.* **A340** 514-523
- [5] Varga D, Tökési K and Rajta I 1995 Design of an electrostatic electron spectrometer for simultaneous energy and angular distribution measurements *J. of Electron Spectroscopy and Rel. Phen.* **76** 433 – 436