



Received: 10/11/2023
Original Research Article

Revised: 22/01/2024

Accepted: 26/02/2024

Published online: 29/03/2024



Open Access under the CC BY -NC-ND 4.0 license

UDC 53.082

AUTOMATED CONTROL OF THE THIN FILMS ELECTRICAL CONDUCTIVITY BY THE EDDY CURRENT METHOD

Malikov V.N.^{1*}, Ishkov A.V.², Voinash S.A.³, Zagidullin R.R.³, Sabitov L.S.^{3,4},
Vornacheva I.V.⁵, Ivanov A.A.⁶

¹ Altai State University, Barnaul, Russia,

² Altai State Agricultural University, Barnaul, Russia

³ Kazan Federal University, Kazan, Russia

⁴ Kazan State Power Engineering University, Kazan, Russia

⁵ South-West State University, Kursk, Russia

⁶ Tver State Agricultural Academy, Tver, Russia

*Corresponding author: osys11@gmail.com

Abstract. The article considers the possibility of using the eddy current method of non-destructive testing for the problems of measuring the electrical conductivity of thin metal films. As the object of measurement, we used copper films of various thicknesses obtained by vacuum vapor deposition. A review of current trends in the use of copper films in modern industry and science is presented, and an analysis is made of current methods of non-destructive testing suitable for studying thin copper films. A brief description of the deposition method and the hardware-software complex for measuring the electrical conductivity of the film is presented. A calibration curve is presented, which makes it possible to restore the values of the electrical conductivity of the film from the value of the signal of the eddy current transducer. GaAs samples were selected to construct a calibration curve. The decision is explained by the proximity of the values of the electrical conductivity of this chemical compound to the calculated indicators of the obtained thin films. The results of testing films with different characteristics are presented and the distribution of the electrical conductivity of the films depending on the batch is shown. A series of practical measurements of thin films demonstrated the existence of a relationship between the mass of the initial substance that was subjected to deposition and the characteristics of the resulting films. According to different values of electrical conductivity within the same batch, it was concluded that there is a difference in the quality of deposition of different films.

Keywords: eddy current transducer, electrical conductivity, thin films, copper, non-destructive testing.

1. Introduction

Currently, in the research environment, there is a rapid development of a direction that studies the production and application of thin layers of material, the thickness of which is in the range from fractions of a nanometer (monoatomic layer) to several microns. Many branches of modern production have turned their eyes towards thin metal films, in view of the prospects that such innovative materials open up. At the moment, thin films are already being used in a wide range of industries, including microelectronics, optics, microwave technology, metalworking, high vacuum technology, etc. These circumstances allow us to talk not only about the improvement of technical characteristics, but also about new technological directions.

Thin films are characterized by an extreme breadth of the spectrum of possible structures and properties, the presence of which is determined by the thickness of such materials. In this regard, the physical properties of thin films can differ significantly from the characteristics of a substance in a bulk state. These circumstances increase the interest in these materials on the part of scientific research, since they can be used to discover properties and regularities previously unknown to physics. In practical terms, the study of thin films is essential in the development of innovative technologies and devices based on them.

At present, the electrical resistance determined by the film thickness is considered to be the key parameter possessed by thin films. Practical developments allow us to make a conclusion that the regulation of the electrical conductivity of thin films makes it possible to control their structure. According to the results of the analysis of modern publications on this topic, the eddy current testing (ECT) is the most optimal direction for continuous non-destructive testing in terms of ecology, ease of use, as well as efficiency and productivity. This method is based on the phenomenon of eddy currents, the excitation of which in the object under study (in this case, in thin metal films capable of conducting electric current) makes it possible to reveal hidden inconsistencies (Figure 3).

As follows from the provisions that have been developed in modern publications, systems with overhead and screen transducers demonstrate a stable efficiency of non-destructive testing using ECT. Researchers focus on such parameters of thin films as specific electrical conductivity, thickness, as well as the detection of violations of the structure of the substance and damage. The development of special transducers and the optimization of existing ones will serve as the basis for creating general principles for the implementation of the necessary control tools.

The use of non-destructive testing methods based on eddy current effects in relation to violations of the structure of the substance of thin films has some specificity compared to typical test objects, which is expressed in the breadth of the spectrum of manifestations. The thickness of thin films varies from fractions of a nanometer to several microns; at the same time, the possible nature of violations of the structure of a substance is diverse. In modern publications devoted to the problems of eddy current testing, some conceptual directions can be traced, which can be recognized as common to the entire field of non-destructive testing, including both the theoretical part and the measuring technique itself. In particular, the emphasis is on improving measurement accuracy and expanding functionality.

Eddy current non-destructive testing systems have their own specificity, which consists in the need for constant changes in the design of sensors in accordance with the conditions of a specific task. These circumstances are due to the fact that the key informative indicator of this approach is the voltage directed to the measuring winding of the converter. It correlates with the consolidated characteristic of the β_0 sensor, which is a function of the nature of the substance, the type and parameters of internal disturbances in the structure, parameters and structure of the converter, as well as the frequency of the exciting alternating electromagnetic field. Also, when calculating the electrical characteristics of the sensor, it is necessary to take into account the defect-sensitive material parameter, the location and parameters of possible violations of the internal structure of materials, and the locality of the eddy current converter.

Electromagnetic non-destructive testing (NDT) is widely used for the evaluation of conductive materials [1–3]. One common approach, ECT, employs a system of coils that induces eddy currents in a conductive sample and subsequently monitors changes in the secondary magnetic field generated by the eddy currents [2, 4]. Defects in the sample distort the eddy currents, resulting in a change in the magnetic field detected by the coils. ECT has limitations, including shallow penetration depth, an inability to detect defects with interfaces parallel to the surface, and the requirement that the probe maintain minimal lift-off from the test material. Despite these limitations, ECT is widely used for NDT and inspection because of the advantages offered in terms of cost, portability and ease of interpretation of results. Currently, the practical utility of ECT is restricted to conductive materials. However, with the growing use of nonconductive materials in industrial applications that require non-destructive evaluation, there is a need for an approach for these materials with comparable advantages to ECT.

During ECT testing, the conductive or semiconductive material is excited by a coil with high frequency alternating currents. Defects including cracks, voids or delamination alter the eddy current distribution around the defect. ECT have been recently used for the inspection of composition materials [5-7]. For example, Liang Cheng et al. [8] compared ECPT with ultrasound and flash thermography for the detection of delamination in composites. However, to date, a quantitative comparison of the damage detection performance of eddy-current method for composite and metallic materials is still missing [9]

Copper (Cu) has become widely used as a connection material in very large integrated circuits due to its low electrical resistance and high resistance to electromigration [10-12]. However, copper can diffuse into silicon dioxide (SiO₂) [13–15] and silicon (Si) at temperatures up to 200°C [16], which has a negative effect on the stability of electronic devices. Recently, many materials have been studied that can be used to create a thin metal film [17–19], but copper remains the most interesting of them, since it is difficult to form an intermetallic compound with Cu/Si, which ensures a relatively stable interface between them. When the thickness of the copper film is reduced to about 600-1000 nm, the measurement of the electrical conductivity of the copper film becomes relevant, both to control the deposition process and to control the thickness. Currently, there are several methods for monitoring electrical conductivity, including the four-probe method (4PP) [20–22], the optical method [23], and the eddy current method [24]. The 4PP method is a common method for determining the thickness of a copper film in the semiconductor industry, but it requires contact of the probes with the sample surface [25]. The optical method uses the principle of interference of a light beam reflected from the surface and bottom of the film [26]. This method is well suited for transparent film, but cannot be applied to metal. The eddy current method [27-29] is a non-destructive and non-contact method with high sensitivity [30-31] that satisfies the requirements for measuring the electrical conductivity of a copper film.

The current range of scanning devices using the principles of eddy currents has limited application to the problems of measuring thin films. The thickness of such materials (100 - 500 nm) causes difficulties in flaw detection and imposes increased requirements on eddy current transducers and other elements of the scanning system. For example, the operating frequency required for efficient investigation of thin films is in the range of 1 – 10 MHz [32].

Summing up the intermediate results, we have reason to speak with confidence about the relevance of this area of research. This publication aims to describe the practice of using the eddy current method of non-destructive testing in the study of the electrical conductivity of thin metal films. Measurements will be carried out using the developed setup based on an ultra-compact transducer that uses the principles of eddy currents and is capable of effectively localizing the electromagnetic field in small areas. According to the scanning plan, the received signal from the eddy current probe will be subjected to hardware and software processing aimed at data analysis using special algorithms.

The successful achievement of this goal necessitates addressing a comprehensive set of tasks:

1. Transducer Design: Develop an eddy current transducer optimized for the specific flaw detection application. This requires selection of the core size and shape, alongside the number and turns of coils within the core, to effectively focus the electromagnetic field onto the object under investigation.
2. Software-hardware system development: Create a dedicated software and hardware system based on the designed transducer. This system should perform precise control of the eddy current testing (ECT) process, encompassing:
 - Generation of alternating current with variable frequencies
 - Coordinated current within the ECT windings
 - Acquisition and clear visualization of the resulting signal
3. Rigorous experimental validation through controlled experiments investigated the electrical conductivity of representative thin film samples, emphasizing accurate determination of their final values.

2. Materials and methods of research

In scientific research, the method of resistive heating of a substance with subsequent deposition from the gas phase in vacuum on a glass substrate has proven itself well as a method for obtaining thin films. This method is characterized by high efficiency, low cost of equipment, safety in operation and small overall dimensions. Copper, which is widely used in science and technology due to the parameters of its electrical conductivity, was chosen as the source of the film material. The evaporation of the substance was carried out in the VUP-5 installation.

The scheme of operation of the vacuum universal post VUP-5 is shown in Figure 1 [33].

On Figure 1 under the symbols are: D1, D2 and D4 is low vacuum pumps, used to remove the main part of the gas from the chamber, D3 is high vacuum pump - to maintain vacuum by removing gas flowing from the surfaces, K is valves, K4 is high vacuum valve. WL is working volume, FP is foreline pump, FC is foreline cylinder, DP is diffusion pump.

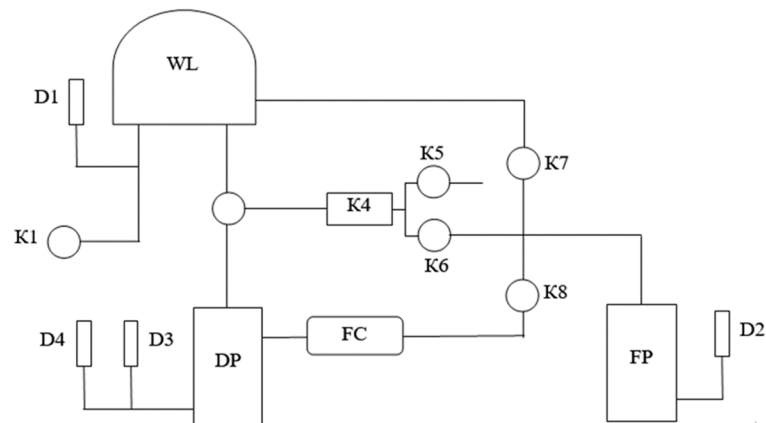

Fig.1. Scheme of work of VUP-5.

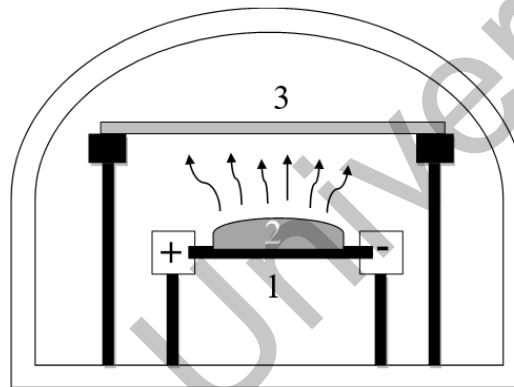

Fig.2. Scheme of evaporation and deposition in a vacuum chamber.
1) evaporator, 2) evaporated substance, 3) substrate

The scheme of evaporation of the source of the film material, as well as subsequent deposition, is shown in Figure 2. The calculated volume of copper is located on a thin tungsten plate, which acts as an evaporator. An electric current is applied to the plate, as a result of which it is heated to high temperatures and leads to the evaporation of the source of the film substance. Breaking away from the surface, the particles of the substance propagate in a vacuum, forming a vapor, which subsequently settles on a glass substrate. The glass plates used for the substrate had different areas.

Differences in the thickness of the final film is due to the different volume of the substance of the film source subjected to evaporation. According to the study plan, the amount of copper increased as the lot number increased. Within the same batch, the film samples also differ in thickness, since they were located in the chamber at different distances from the center of the evaporator.

The transducer is positioned perpendicular to the plane of the film under study, so that the measuring winding is at a minimum distance from the surface of the film, but the ECP is not in contact with it.

To control the operation of the developed converter, automate the measurement process and convenient visualize the results obtained, a hardware and software complex is required.

The developed diagram of the software and hardware complex is presented in Fig. 2.

The control unit, executed on the basis of a personal computer (PC), generates and sends commands to the generator (GEN) and the VTP positioning system. The generator, having received a control signal, generates an alternating electric current of a given frequency, which, passing through the Amplifier, acquires a given amplitude and is supplied to the exciting coil of the VTP.

The voltage on the measuring coil, passing through the Amplifier and Filter, is supplied to an analog-to-digital converter and then, in the form of a digital signal, enters the processing and visualization unit (PC). To move the ECP over the object of study, a positioning system based on Cartesian kinematics, based on a Cartesian coordinate system, was developed; this technology operates on the basis of three axes is X, Y, Z.

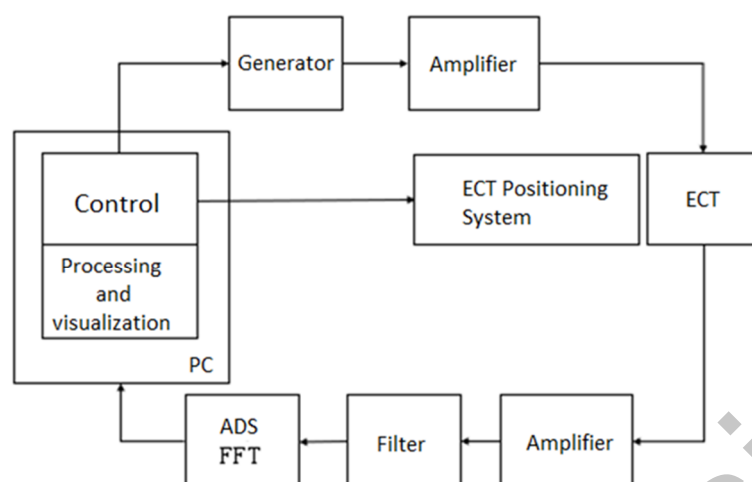

Fig.3. Scheme of the eddy current complex

The platform for securing the research object moves along the Y axis, and the sensor holder moves along the X and Z axis. Each direction has its own motor, the Y and X axes have a belt drive, the Z axis is driven by a screw system consisting of a stepper motor, a flexible coupling and a screw, the pitch of which determines the step size along this axis. The maximum size of the probing area is 22×22 cm, the maximum movement speed is 180 mm/s, the movement accuracy is 100 μm .

3. Results and discussion

To conduct direct measurements of electrical conductivity with the involvement of an eddy current transducer, a scale was compiled in units of the measured value and equipped with a calibration curve (Figure 4.). Approximation was carried out using the least squares method. Gallium arsenide GaAs samples were selected to construct a calibration curve. GaAs samples were cylinders of various sizes, with different types of conductivity (p, n), mobility (200-2400 cm^2/s), carrier concentration ($3,75 \cdot 10^{17}$ - $3,3 \cdot 10^{18}$ $1/\text{cm}^3$) and dislocation density (10^4 - $3 \cdot 10^4$). The solution is explained by the closeness of the values of the electrical conductivity of this chemical compound to the calculated values of the obtained thin films. The operating frequency during direct measurement was 7 MHz, the signal amplitude was 1.45 V. The results obtained are shown in Table 1.

Table 1. Response amplitude from GaAs.

Electrical conductivity of the standard, MSm	0.00138	0.001792	0.071808	0.09984	0.09216	0.11616	0.12144
Amplitude, V	0.02125	0.02247	0.08553	0.09716	0.09847	0.10520	0.10828

To compile a holistic picture of the studied parameters, the results of the responses of the scanning eddy current system were collected and analyzed when measuring samples of thin films from different batches. Several batches of films with different materials and thicknesses were obtained using the resistive evaporation method. The thickness of the films in different batches varied from 100 to 800 nm, which was achieved by using different amounts of the evaporated material. The substrate dimensions were 23 x 23 mm. The films had a polycrystalline structure. Figure 5 shows the results of the measurement of the obtained samples from the first batch. It can be observed how the distribution of the incoming signal from the eddy current transducer shown in the image is uniform. Thus, we get grounds to speak about the uniformity of the deposition of the film substance and, accordingly, the quality of the material obtained.

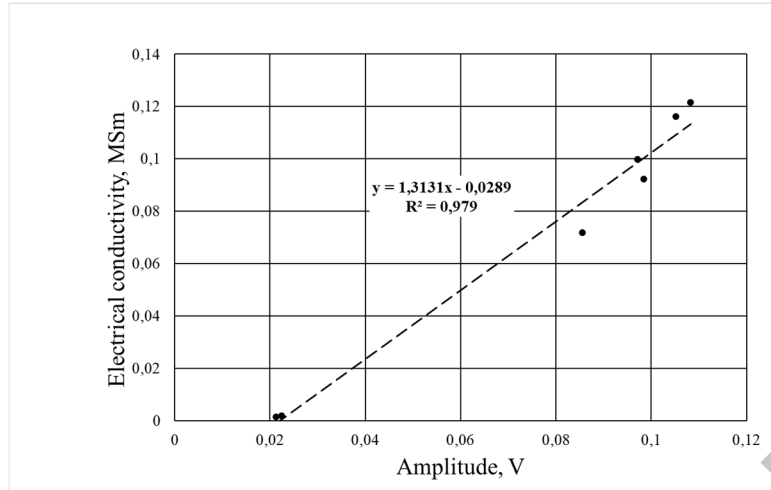

Fig.4. Calibration curve based on GaAs.

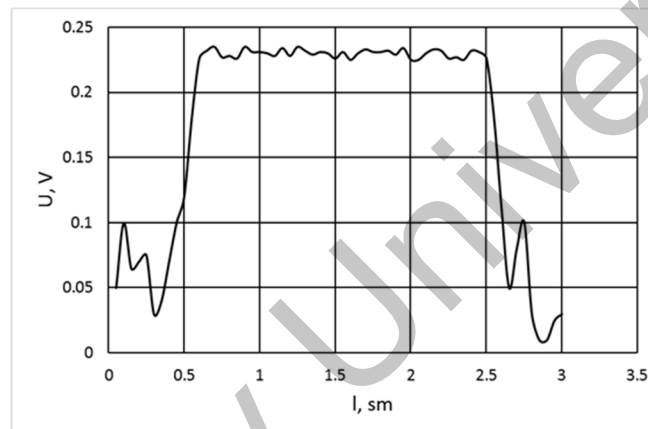

Fig.5. Results of measurements of films from batch No. 1.

Figure 6 shows the results of measuring films from the second batch. The nature of the incoming signal from the ECP has changed significantly: we can confidently speak of the presence of two regions with different signal amplitudes. This indicates the existence of some differences in the electrical conductivity of different regions of the same sample. It is important to note that within the boundaries of these areas, the signal is largely stable.

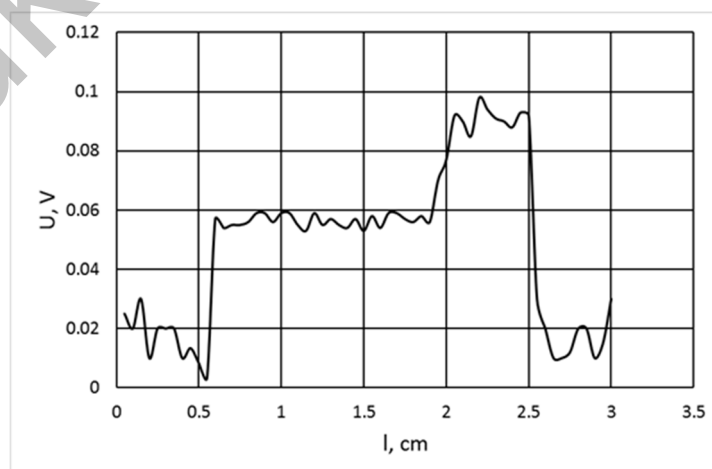

Fig.6. Results of measurements of films from batch No. 2.

Figure 7 shows the results of measuring films from the third batch of films. Judging by the nature of the distribution of the signal coming from the transducer, the samples also contain regions with different electrical conductivity (similar to the picture in the second batch). However, unlike the second batch, even within the same region, the signal is not stable either, the limits of signal change are quite wide. Thus, the electrical conductivity varies both in individual areas and throughout the sample.

Figure 8 shows the results of measuring films from the fourth batch of films. The picture demonstrates the unsystematic nature of the distribution of the signal level from the eddy current transducer. This is explained by the fact that the electrical conductivity of the samples varies significantly over their entire area without the possibility of isolating relatively stable regions. This can be explained by a change in the structure of conductive films and, accordingly, the mechanisms of movement of electric charges that create an electric current.

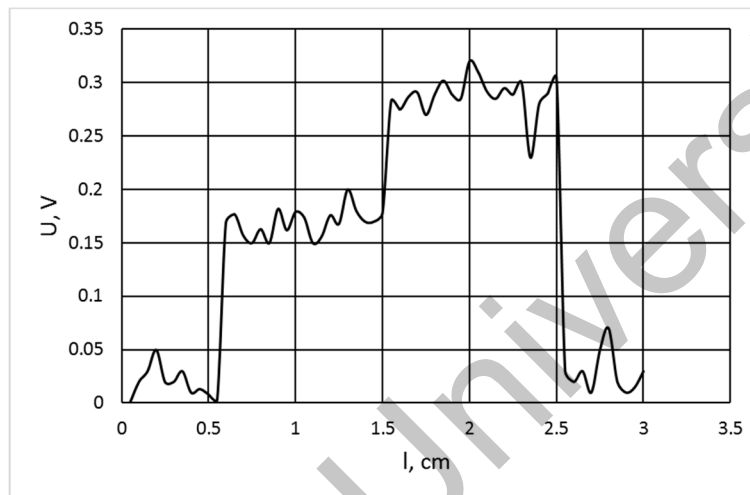

Fig. 7. Results of measurements of films from batch No. 3.

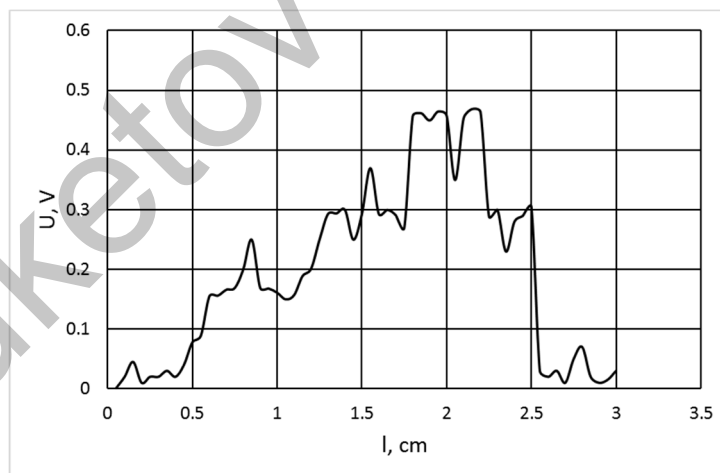

Fig. 8. Results of measurements of films from batch No. 4.

The results of film measurements are shown in Table 2.

Table 2. Average conductivity by batch.

Sample No.	Party 1 (1)	Party 1 (2)	Party 2 (1)	Party 2 (2)	Party 3 (1)	Party 3 (2)	Party 4 (1)	Party 4 (2)
Electrical conductivity MSm	0,28	0,23	0,084	0,087	0,138	0,22	0,80736	0,22469

4. Conclusion

Summing up the results of the study, it is necessary to note some key provisions.

1. In particular, it was possible to work out the practical aspects of obtaining thin metal films with various parameters, including thickness, electrical conductivity, and oxidation resistance. As part of the study, a VUP-5 vacuum unit was used to create several batches of thin films by resistive deposition.

2. To measure individual parameters of thin metal films, which are of the greatest interest, a special scanning setup was developed on the basis of an ultra-compact transducer using the principles of eddy currents.

3. The measuring setup was successfully tested on thin copper films and proved to be effective in establishing the values of the parameters of interest. The response from the measuring winding, which is part of the ECT, which is the result of the interaction of the transducer field with the film, has sufficient information content for subsequent analysis.

4. The method of calibration of the scanning setup using samples with known electrical conductivity was used in the work. Both high and low electrical conductivity values were included in the system. This made it possible to build a calibration curve, which can be used as a guide when obtaining the calculated values of the conductivity of the current film.

5. Analysis of the amplitude values of the input signal, which by their nature are derivatives of the interaction of the magnetic field of the transducer with the film, carried out taking into account the calibration curve, makes it possible to draw conclusions regarding the electrical conductivity values of thin films from different batches.

6. A series of practical measurements of thin films demonstrated the existence of a relationship between the mass of the initial substance that was subjected to deposition and the characteristics of the resulting films. This circumstance indicates that the stability of the values of the parameters of the final materials can be achieved by increasing the accuracy of taking into account the mass of the initial substance.

The scientific and practical significance of the results obtained in the work are as follows:

1. For the first time, a design of an eddy current transducer with characteristics that enables thin metal film analysis, including detecting and characterizing defects and inhomogeneities with an area of 10,000 μm^2 and more, as well as determining the coordinates of film boundaries.

2. A dedicated software-hardware system based on the eddy current method was developed to enable experimental investigation of inhomogeneities and defects in thin metal films with a thickness of 100 nm or more and a specific conductivity of 14 MS/m.

3. The determined frequency range of the excitation signal of the eddy current transducer is 10-30 MHz, which allows for research of defects in the structure of films with a thickness of 100 nm and more.

Conflict of interest statement

The authors declare that they have no conflict of interest in relation to this research, whether financial, personal, authorship or otherwise, that could affect the research and its results presented in this paper.

CRedit author statement

Malikov V.N.: Conceptualization, Methodology; Ishkov A.V.: Software; Voinash S.A.: Validation; Zagidullin R.R. and Sabitov L.S.: Writing - Review & Editing; Vornacheva I.V. and Ivanov A.A.: Supervision.

The final manuscript was read and approved by all authors.

Funding

This project was funded by the Russian Science Foundation, project No. 21-79-00026 «Development of hardware and software complexes for the study of conductive materials based on subminiature eddy-current transducers».

Acknowledgments

The work is carried out in accordance with the Strategic Academic Leadership Program "Priority 2030" of the Kazan Federal University of the Government of the Russian Federation.

References

- 1 Sophian A., Tian G.Y. Electromagnetic and eddy current NDT: A review. *Insight*, 2001, Vol. 43, pp. 302–306. https://www.researchgate.net/publication/282684852_Electromagnetic_and_eddy_current_NDT_A_review
- 2 Auld B.A., Moulder J.C. Review of Advances in Quantitative Eddy Current Nondestructive Evaluation. *J. Nondestruct. Eval.*, 1999, Vol. 18, pp. 3–36. <https://doi.org/10.1023/A:1021898520626>
- 3 Garcia-Martin J., Gomez-Gil J., Vazquez-Sanchez E. Non-Destructive Techniques Based on Eddy Current Testing. *Sens.*, 2011, Vol. 11, pp. 2525–2565. <https://doi.org/10.3390/s110302525>
- 4 Lee H., Jane E., Kevin M. Low Frequency Eddy Current Testing of Insulators and Composites. *J. of Nondestr. Eval.*, 2018, Vol. 37, pp. 58-70. <https://doi.org/10.1007/s10921-018-0513-1>
- 5 Mizukami K., Mizutani Y., Kimura K., Sato A. Visualization and size estimation of fiber waviness in multidirectional CFRP laminates using eddy current imaging. *Compos. Part A.*, 2016, Vol. 90, pp. 261–70. <https://doi.org/10.1016/j.compositesa.2016.07.008>
- 6 Gao B., Lu P., Woo W. L., Tian G. Y., Zhu Y., Johnston M. Variational Bayesian subgroup adaptive sparse component extraction for diagnostic imaging system. *IEEE Trans. Ind. Electron.*, 2018, Vol. 65, No 10, pp. 8142–8152. <https://doi.org/10.1109/TIE.2018.2801809>
- 7 Abidin I. Z., Tian G. Y., Wilson J., Yang S., Almond D. Quantitative evaluation of angular defects by pulsed eddy current thermography. *NDT E Int.*, 2010, Vol. 43, No 7., pp. 537–546. <http://dx.doi.org/10.1016/j.ndteint.2010.05.010>
- 8 Cheng L., Tian G. Y. Surface crack detection for carbon fiber reinforced plastic (CFRP) materials using pulsed eddy current thermography. *IEEE Sensors J.*, 2011, Vol. 11, No 12, pp. 3261-3268. <https://doi.org/10.1109/JSEN.2011.2157492>
- 9 Zijun W., Junzhen Z., Gui Yun T., Francesco C. Comparative analysis of eddy current pulsed thermography and long pulse thermography for damage detection in metals and composites. *NDT E Int.*, 2019, Vol. 107, pp. 102–155. <https://doi.org/10.1016/j.ndteint.2019.102155>
- 10 Zhu Q., Zhang X., Li S., Liu C. Communication-electrodeposition of nano-twinned Cu in void-free filling for blind microvia of high density interconnect. *Journal of The Electrochemical Society*, 2019, Vol. 166, No 1, pp. 3097-3099. <https://doi.org/10.1149/2.0131901jes>
- 11 Liang C.L., Lin K.L. Non-equilibrium supersaturation behavior in a Cu/Sn/Cu interconnect induced by room temperature electromigration. *Journal of Alloys and Compounds*, 2019, Vol. 789, No 15, pp.336-344. <https://doi.org/10.1016/j.jallcom.2019.03.055>
- 12 Baklanov M.R., Adelman C., Zhao L., Gendt S.D. Advanced interconnects: materials, processing, and reliability. *ECS Journal of Solid State Science and Technology*, 2015, Vol. 4, No 1, Y1-Y4. <https://doi.org/10.1149/2.0271501jss>
- 13 Shang J., Hao J.X., Hang T., Li M. Diffusion barrier effect of Ta/Ti bilayer in organic dielectric/Cu interconnects. *Thin Solid Films*, 2018, Vol. 653, No 1, pp.113-118. <https://doi.org/10.1016/j.tsf.2018.03.025>
- 14 Mardani S., Norström H., Smith U. Electromigration behavior of Cu metallization interfacing with Ta versus TaN at high temperatures. *Journal of Vacuum Science & Technology*, 2016, Vol. B, 34. <http://dx.doi.org/10.1116/1.4967372>
- 15 Laurila T., Zeng K., Kivilahti J.K. Failure mechanism of Ta diffusion barrier between Cu and Si. *Journal of Applied Physics*, 2000, Vol. 88, pp. 3377-3384. <https://doi.org/10.1063/1.1288692>
- 16 Ono H., Nakano T., Ohta T. Diffusion barrier effects of transition metals for Cu/M/Si multilayers (M=Cr, Ti, Nb, Mo, Ta, W). *Applied Physics Letters*, 1994, Vol. 64, No. 12, pp.1511-1513. <https://doi.org/10.1063/1.111875>
- 17 Fang J.S., Chen J.H., Chen G.S., Cheng Y.L., Chin T.S. Sequential growth of copper film on TaN/Ta barrier substrates by alternation of Pb-UPD and Cu-SLRR. *Electrochimica Acta*, 2016, Vol. 206, No.10, pp. 45-51. <https://doi.org/10.1016/j.electacta.2016.04.129>
- 18 Lane M., Dauskardt R.H. Adhesion and reliability of copper interconnects with Ta and TaN barrier layers. *Journal of Materials Research*, 2000, Vol. 15, No 1. pp. 203-211. <https://doi.org/10.1557/JMR.2000.0033>
- 19 Zantye P.B., Kumar A., Sikder A.K. Chemical mechanical planarization for microelectronics applications. *Materials Science and Engineering: R: Reports*, 2004, Vol. 45, No 3-6, pp. 89-220. <https://doi.org/10.1016/j.mser.2004.06.002>
- 20 Wrschka P., Hernandez J., Oehrlein G.S. Chemical mechanical planarization of copper damascene structures. *Journal of The Electrochemical Society*, 2000, Vol. 147, No. 2, pp. 706-712. <https://doi.org/10.1149/1.1393256>
- 21 Xu Q., Fang J., Chen L. A chip-scale chemical mechanical planarization model for copper interconnect structures. *Microelectronic Engineering*, 2016, Vol. 149, No 5, pp.14-24. <https://doi.org/10.1016/j.mee.2015.08.012>
- 22 Bowler N., Huang Y.Q. Electrical conductivity measurement of metal plates using broadband eddy-current and four-point methods. *Measurement Science and Technology*, 2006, Vol. 16, No 11, pp. 2193-2200. <https://doi.org/10.1088/0957-0233/16/11/009>

- 23 Fujita T., Kitade K. Development of endpoint detection using optical transmittance and magnetic permeability based on skin effect in chemical mechanical planarization. *Precision Engineering*, 2019, Vol. 57, pp. 95-103. <https://doi.org/10.1016/j.precisioneng.2019.03.004>
- 24 Wang Z., Yu Y. Thickness and Conductivity Measurement of Multilayered Electricity-Conducting Coating by Pulsed Eddy Current Technique: Experimental Investigation. *IEEE Transactions on Instrumentation and Measurement*, 2019, Vol. 68, No 9, pp.3166-3172. <https://doi.org/10.1109/TIM.2018.2872386>
- 25 Kjeldby S.B., Evenstad O.M., Cooil S.P., Wells J.W. Probing dimensionality using a simplified 4-probe method. *Journal of Physics: Condensed Matter*, 2017, Vol. 29, No 39, pp.1-6. <https://doi.org/10.1088/1361-648X/aa8296>
- 26 Kim M.G., Pahk H.J. Fast and reliable measurement of thin film thickness profile based on wavelet transform in spectrally resolved whitelight interferometry. *International Journal of Precision Engineering and Manufacturing*, 2018, Vol. 19, No 2, pp. 213-219. <https://doi.org/10.1007/s12541-018-0024-0>
- 27 Dmitriev S.F., Malikov V.N., Ishkov A.V. Application of an eddy-current method to measure electrical conductivity of thin films. *IOP Conf. Series: Materials Science and Engineering*, 2018, Vol. 441, 012029. <https://doi.org/10.1088/1757-899X/441/1/012029>
- 28 Li W., Wang H., Feng Z. Non-contact online thickness measurement system for metal films based on eddy current sensing with distance tracking technique. *Review of Scientific Instruments*, 2016, Vol. 87, No 4, pp. 1-9. <https://doi.org/10.1063/1.4947234>
- 29 Wang H., Li W., Feng Z. Noncontact thickness measurement of metal films using eddy-current sensors immune to distance variation. *IEEE Transactions on Instrumentation and Measurement*, 2015, Vol. 64, No 9, pp. 2557-2564. <https://doi.org/10.1109/TIM.2015.2406053>
- 30 Li W., Ye Y., Zhang K. A thickness measurement system for metal films based on eddy current method with phase detection. *IEEE Transactions on Industrial Electronics*, 2017, Vol. 64, No. 5, pp. 3940-3949. <https://doi.org/10.1109/TIE.2017.2650861>
- 31 Sakran F., Golosovsky M., Goldberger H. High frequency eddy-current technique for thickness measurement of micronthick conducting layers. *Applied Physics Letters*, 2001, Vol. 78, No 11, pp. 1634-1636. <https://doi.org/10.1063/1.1355298>
- 32 Yin W.L., Xu K. A novel triple-coil electromagnetic sensor for thickness measurement immune to lift-off variations. *IEEE Transactions on Instrumentation and Measurement*, 2016, Vol. 65, No 1, pp. 164-169. <https://doi.org/10.1109/TIM.2015.2479106>
- 33 Porada O.K., Ivashchenko V.I. Plasma-Enhanced CVD Equipment for Deposition of Nanocomposite Nanolayered Films. *Journal of Superhard Materials*, 2019, Vol. 41, pp. 32-37. <https://doi.org/10.3103/S1063457619010040>

AUTHORS' INFORMATION

Malikov, V.N. – Candidate of Techn. Sciences, Associate Professor, Department of General and Experimental physics, Altai State University, Barnaul, Altai Territory, Russia; ORCID iD: 0000-0003-0351-4843; osys11@gmail.com

Ishkov, A.V. – Doctor of Techn. Sciences, Candidate of Chem. Sciences, Professor, Department of Technology structural materials and repairs machines, Altai State Agricultural University, Barnaul, Russia; ORCID iD: 0000-0003-1637-2258; svaritfffi@gmail.com

Voinash, S.A. – Junior researcher, Research laboratory "Intelligent Mobility", Institute of Design and Spatial Arts, Kazan Federal University, Kazan, Russia; Scopus Author ID: 57194339935; ORCID iD:0000-0001-5239-9883; sergey_voi@mail.ru

Zagidullin R.R. – Candidate of Techn. Sciences, Associate Professor, Kazan Federal University, Kazan, Russia; ORCID iD: 0000-0001-5185-2690; r.r.zagidullin@mail.ru

Sabitov L.S. – Doctor of Techn. Sciences, Professor, Kazan Federal University, Kazan, Russia; ORCID iD: 0000-0001-7381-9752; l.sabitov@bk.ru

Vornacheva, I.V. – Candidate of Techn. Sciences, Associate Professor, Southwestern State University, Kursk, Russia; ORCID iD: 0009-0003-5511-235X; vornairina2008@yandex.ru

Ivanov, A.A. – Candidate of Techn. Sciences, Associate Professor, Tver State Agricultural Academy, Tver, Russia; ORCID iD: 0000-0001-8190-0577; aivanov@tvqsha.ru