

UDC 535.37:535.34:539.19

**RESEARCH THE NATURE OF IMPURITY CENTERS IN KDP-MNSO<sub>4</sub> CRYSTAL**

T.A. Koketai, A.K. Tussupbekova, A.S. Baltabekov, A.A. Ganyukova, S.A. Nukygaziy

E.A. Buketov Karaganda State University,  
Universitetskaya Str. 28, Karaganda, 100028, Kazakhstan

*In the work research of impurity centers types in KDP-MnSO<sub>4</sub> crystal is carried out. It is revealed that when activation the KDP crystal with sulphatic salts of Mn<sup>2+</sup> ions two types of the impurity centers in a crystal lattice are formed. The first type of the impurity centers gives a long-wave absorption band and is not directly involved in radiation stimulated processes. The second type of the impurity centers changes charging states as a result of external influence. The experimental results agree well with the theoretical findings.*

**Keywords:** potassium dihydrogen phosphate (KDP), crystal, impurity centers, absorption band, thermally stimulated luminescence (TSL).

**Introduction**

Potassium dihydrogen phosphate (KDP) crystals are widely used for electro-optical applications such as Q-switching for alexandrite lasers, as well as for acousto-optical applications. Single crystals of KDP are used for frequency doubling and tripling of laser systems [1, 2]. The effect of doping divalent metal ions, such as Co<sup>2+</sup>, Ni<sup>2+</sup>, Mn<sup>2+</sup> etc., on KDP crystals has been extensively studied [2, 3]. We have investigated the effect of Me<sup>2+</sup> doping on KDP crystal in detail and the studies research the nature of impurity centers.

**1. Experiment methods and objects**

In the work the following crystals were investigated as objects: potassium dihydrogen phosphate KH<sub>2</sub>PO<sub>4</sub> (KDP) (purgist); KDP: Co<sup>2+</sup> (0.1 m of %, 185 °C, 3 h, d=5 mm); KDP: Ni<sup>2+</sup> (0.1 m of %, 180 °C, 2.5 h, d=5 mm); KDP: Mn<sup>2+</sup> (0.1 m of %, 180 °C, 2.5 h, d=5 mm).

Objects were synthesized by the cultivation method from aqueous solution. Ions of divalent transitional metals were introduced into matrix by introduction of sulphatic and nitrate salts of these metals. As activators Co<sup>2+</sup>, Ni<sup>2+</sup>, Mn<sup>2+</sup> ions were considered.

Measurements of thermally stimulated luminescence (TSL) ranges were taken in the temperature range 80-370 K by means of the experiment installation which flowchart is provided by Fig. 1. The main part of installation is the vacuum monochromator VMR-2 with the following main characteristics: the angular aperture 1:16; inverse linear dispersion of 1,66 nm/mm; working vacuum in the device 5·10<sup>-5</sup> mm hg.

The radiation VUV source – quartz flowing lamp (5) is densely vacuumly attached to the entrance slit of monochromator in which there is the charge of Hydrogenium of VMR-2. Operating mode of the lamp: pressure in a capillary of 1-3 Tor (diameter of a capillary 3 mm); ignition voltage ~ 2000 B; running voltage 600-800 B (I=0,4 A).

The luminescence of the impurity centers was allocated by means of monochromator of MDR-4 or by means of the fitted light filters. The temperature of object was registered by copper-constant thermocouple (4). Heat rate at measurement of curve TSL was constant and made 10 K/min.

For measurement of thermoactivated characteristics the object after radiation turned together with a crystal-holder to 90<sup>0</sup> degrees for illumination by the stimulating light which caused the luminophor luminescence. The 100 V filament lamp was a source of stimulation. The heat of a lamp could be changed.

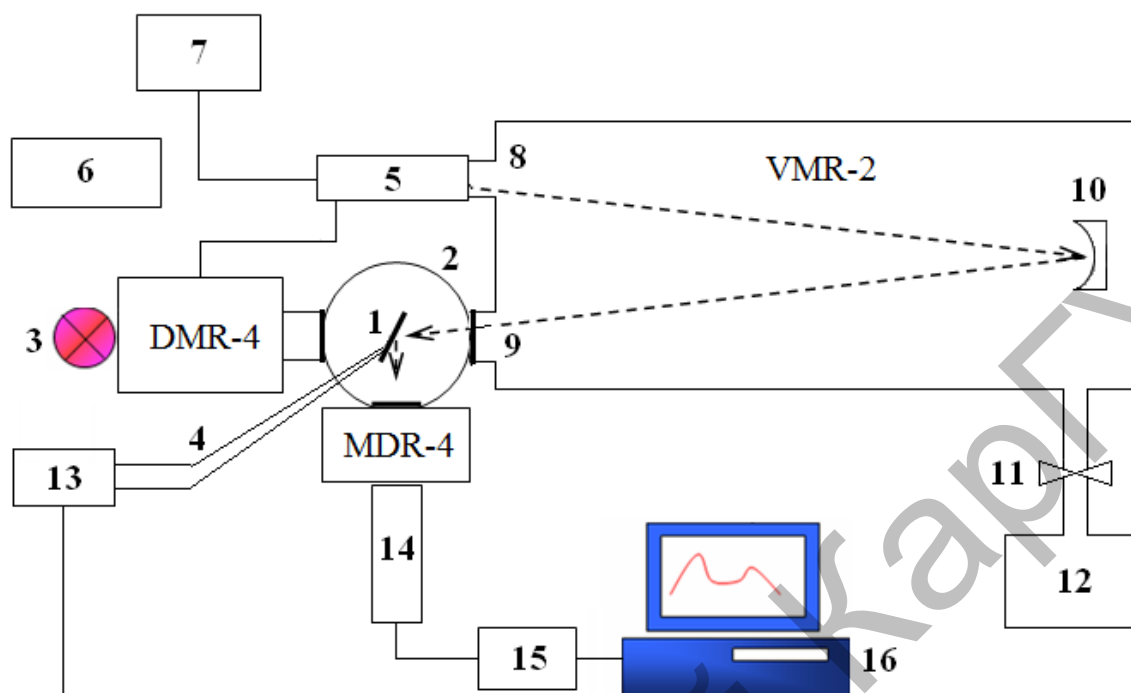

1 – the studied exemplar, 2 – a cryostat with quartz and *LiF* windows, 3 – a filament lamp for illumination, 4 – the thermocouple, 5 – flowing hydrogen lamp, 6 – Hydrogenium generator, 7 – high-voltage electrical power unit of hydrogen discharge lamp, 8 – entrance slit of vacuum monochromator, 9 – exit slit of vacuum monochromator, 10 – the diffraction lattice of  $R=1$  m, 11 – the vacuum valve, 12 – vacuum booster pump, 13 – the voltmeter, 14 – the photoelectronic multiplier, 15 – direct-current amplifier, 16 – computer

Fig.1. The flowchart of installation for research FSL and TSL

For extracting the stimulating photons ( $h\nu_s$ ) the double monochromator DMR-4 was used (with glass prisms). The inverse dispersion of DMR-4 monochromator increases linearly, for example, for area of 2 eV it was equal 9.4 nm/mm, and in the field of 3 eV – 2.8 nm/mm. When illumination the identical width of cracks about 2 mm were established. Calibration of the filament lamp on constant quantum current was carried out with use of FEU-39.

For X-ray radiation of crystals X-ray equipment URS-55a with a tube BSV-2 and the tungsten anode was used. Operating mode of tube 14.9 mA and 49.9 kV. Radiation of object was carried out through a beryllic window of cryostat at the temperature of fluid nitrogen which for this purpose was removed from installation beforehand. The data obtained by means of the computer was processed by means of the OriginPro program.

In all optical measurements the studied object was placed into nitric cryostat with quartz windows. Possibility of turn of a crystal holder of rather vertical axis is provided in the construction of cryostat. The temperature was registered with the differential thermocouple.

When radiation the object by photons a hydrogen lamp was used. Radiation was carried out for 30 min. with activation energy of  $E_{ex} = 8.8$  eV; 10.2 eV; 10.5 eV at  $T = 80$  K. Heating temperature made 10 K/min and was controlled by means of the thermocouple the signal with which was transferred to the digital voltmeter. The luminescence of object was registered with the photoelectronic multiplier which signal arrived on an entrance of Polon and was processed by the computer. For X-ray radiation lead protection for the irradiated part of installation was made. For a X-irradiation in a cryostat there is a beryllic window. The object was irradiated at a temperature of fluid nitrogen with X- rays through the beryllic window of the device. The X-ray tube has a

tungsten anticathode, current in the tube -14.9 mA, voltage – 49.9 kV. Radiation time is 10; 30; 60 min. Besides removal of TSL objects TSL of empty copper substrate were removed as well.

## 2. Results and discussion

Measurements of the curves of thermally stimulated luminescence (TSL) of a dihydrophosphate of potassium (KDP) activated by ions of the transitional metals showed that introduction the matrix of divalent cobalt sulphates, nickel or manganese into crystal lattice leads to emergence of new peaks of recombinational luminescence (fig. 2). In all exemplars new peaks of TSL with maxima at 140K and 220K were observed (fig. 2). Only in crystals with impurity of sulphate of manganese there is a luminescence peak with a maximum at 230K (curve 1, fig. 2). As sulphatic anions are contained in all studied exemplars, the emergence of this peak of TSL is caused by existence of the impurity ions of manganese.

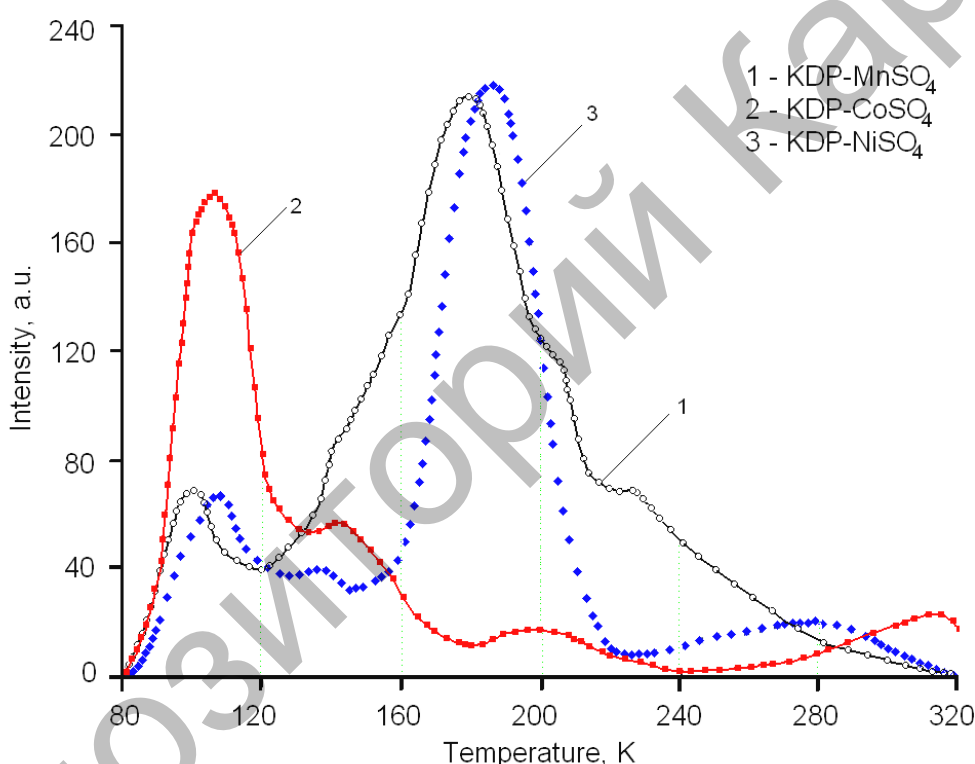

Fig.2. Curve TSL for crystals of KDP activated by ions  $Mn^{2+}$ ,  $Co^{2+}$ ,  $Ni^{2+}$

It is known [1] that when activation the crystals KDP by manganese sulfate ions of metal take intercluster positions in a crystal lattice. The impurity ions in the intercluster positions do not form luminescence centers, i.e. they are optically inactive [2]. Similarity of curve TSL for all ions of the transitional metals including divalent copper [3, 4], allows to assume that all of them take mainly intercluster positions in a crystal lattice of KDP. An exception somewhat are manganese ions.

The absorption spectrum received for pure KDP crystal is given on Fig. 2 (curve 1, fig. 3) and for KDP- $CoSO_4$  crystal (curve 2, fig. 3). Measurements were taken at ambient temperature.

From Fig. 3 it is clear that in the field of 1.5-1.8 eV in the activated crystal the edge of a new absorption band is observed. Its emergence is bound to existence in exemplars of divalent cobalt ion. Earlier it was found out that the impurity sulphatic ions in a crystal lattice KDP do not give absorption bands [3, 4]. It is experimentally established that when radiation by X-ray quanta of optical density changes in the impurity absorption band is not present.

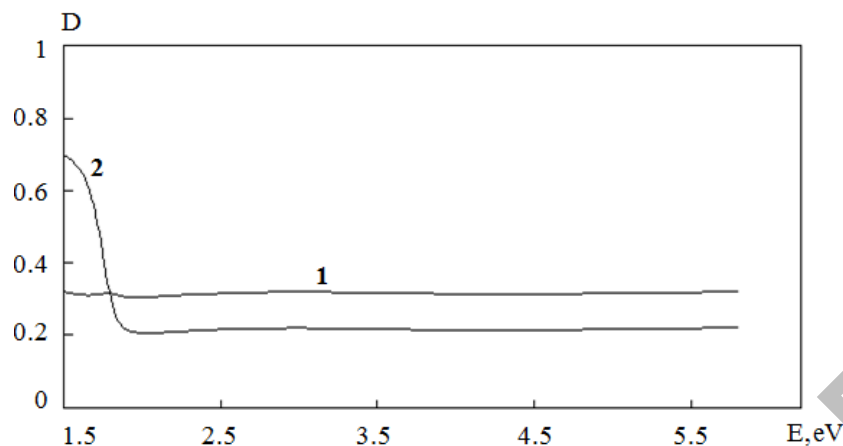

Fig.3. Absorption spectra for pure crystal of KDP (curve 1) and for KDP-CoSO<sub>4</sub> crystal (curve 2), measured at ambient temperature

Therefore, ions of divalent cobalt do not participate in radiation and stimulated processes. They have only impact on them. In KDP-MnSO<sub>4</sub> crystals the situation a bit different. In Fig. 4 the absorption spectrum measured at 80K is presented.

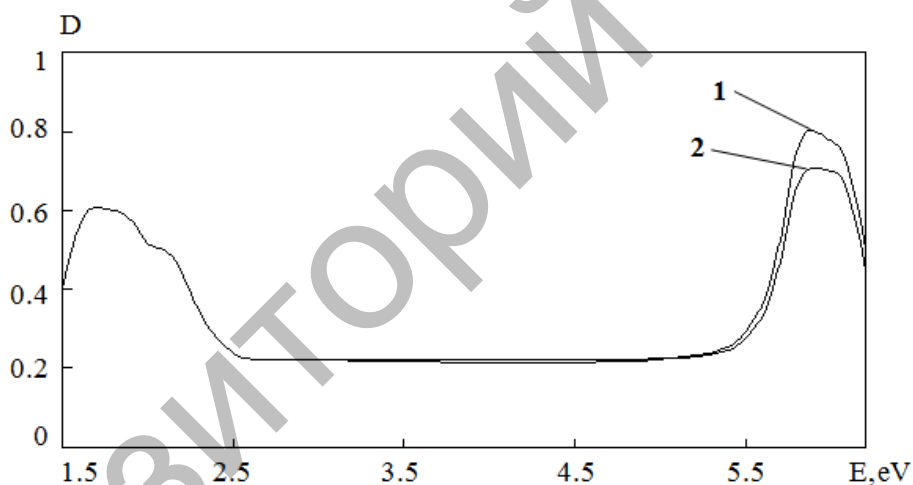

Fig.4. Spectra of additional absorption for KDP-MnSO<sub>4</sub> crystal at the temperature of 80K

In the field of matrix transparence there are two nonelementary wide bands of optical absorption in the field of 1.5-2.2 eV and in the field of 5.7-6.2 eV. It is apparent that emergence of these absorption bands is bound to electronic transitions of the impurity ions of metal. Here the absorption spectrum for KDP-MnSO<sub>4</sub> measured at the temperature of fluid nitrogen after radiation by X-ray quanta is given. KDP crystals under the influence of the ionizing radiation are coloured. The radiation induced bands of optical absorption with maxima at 2.26 eV, 3.17 eV and 5.75 eV are observed. These bands of optical absorption are bound to B-radical and hydrogen atoms in the intercluster positions. The emergence of own absorption of matrix complicates the direct observing of radiation influence by the ionizing radiation on the optical density in absorption bands of manganese ions. Therefore measurements of absorption spectra before and after radiation for crystals KDP-MnSO<sub>4</sub> were taken rather pure crystals KDP which were also exposed to a X-irradiation along with the first exemplar.

From Fig. 4 it is clear that after radiation the optical density in a short-wave band of the impurity absorption decreased. At the same time the optical density for a long-wave band did not

change. This result allows to draw the following conclusion: manganese ions at activation KDP by their sulphate form two types of the impurity centers in a crystal lattice. One of them gives a long-wave absorption band and it is not directly involved in radiation and stimulated processes. Decrease of optical density after radiation by ionizing radiation in a short-wave absorption band has the only explanation.

The second type of the impurity centers as a result of external influence changes charging states. As the similar phenomenon is not present in the exemplars activated by cobalt ions, it allows formulate following assumption: when activation KDP by means of manganese sulphate the part of ions of metal becomes replacement impurity. There is some contradiction with work [5] where it is said that when manganese sulphate use ions of the transitional metal take mainly intercluster positions in KDP lattice. However, authors of this work do not claim that it belongs to all impurity ions.

## Conclusions

The set of all received results allows claim that the long-wave band of optical absorption KDP-MnSO<sub>4</sub> is caused by manganese ions in the intercluster positions, and short-wave – the impurity ions of replacement. The last at radiation by X-ray quantum form the impurity radiation induced centers which disintegration leads to emergence of TSL peak with a maximum at 230K.

## REFERENCES

- 1 Ramasamy G., Meenakshisundaram S.P., Mojumdar S.C. Influence of s-, p-, d- and f- block elements doping on the optical and thermal properties of potassium dihydrogen phosphate crystals. *J. Therm. Anal. Calorim.*, 2013, Vol. 112, pp. 1121 – 1125.
- 2 Baltabekov A.S., Kim L.M., Tagayeva B. S. Influence of manganese ions on recombinational luminescence in potassium phosphate crystals. *Vestnik of the KSU. Physics series*, 2006, No. 2, pp. 4-8.
- 3 Koketay T.A., Tagayeva B. S., Tussupbekova A.K. Influence of impurity ions of the transitional metals on radiation processes in crystals of a dihydrophosphate of potassium and potassium sulphate. *Proceeding of the 12<sup>th</sup> International Scientific Conference «Physics of Solid State»*, Astana, ENU named after L. N. Gumilev, 2014, pp. 196-198.
- 4 Tagayeva B. S., Kim L.M., Tussupbekova A.K. Influence of the impurity ions of copper on recombinational processes in KDP crystals. *Proceeding of the VIII<sup>th</sup> / International Scientific- Practical Conference «Science and Education without Borders»*, *Physics. Mathematics*. Budownictwo I architektura: Przemysl. Nauka I studia, 2012, Vol. 33, pp. 16-19.
- 5 Kim L.M., Kuketayev T.A., Tagayeva B. S. The radiation and stimulated processes in KDP crystals activated by copper ions. *Theses of the 7<sup>th</sup> International Scientific Conference on Nuclear and Radiation Physics*. Almaty, 2009, p. 132.
- 6 Voronov A.P., Vyday Yu.T., Salo V.I., Puzikov V.M., Bondarenko S.I. Influence of thallium doping on scintillation characteristics of mixed KDP/ADP crystals. *Radiation Measurements*, 2007, Vol. 42, No.4/5, pp.553 – 556.