

UDC 532.1+539.19+541.6

## COMPUTER SIMULATION FOR THE FLOW OF HIGH-TEMPERATURE MELTS

Kazhikenova S.Sh.

Karaganda State Technical University, Karaganda, Kazakhsnan, sauleshka555@mail.ru

*One of the most constructive methods of studying physical properties of melts is computer simulation. This is explained by a large theoretical and applied value of the information obtained with respect to the transfer coefficients, in particular, bulk and shear viscosities. However, for specific calculations there is needed a detailed physical-and-mathematical apparatus. Objective - implementation methods of numerical solution of hydrodynamic equations involving correlation functions viscosity determined using quantum potentials study of the distribution profile of melt flow rate, to obtain the most simple regularization of the original system of hydrodynamic equations containing a physical sense. To implement such a program we will use methods of statistical physics. To the moment of the proposed studies, there were known the ways of solving equations of hydrodynamics for low-temperature liquids without taking into account bulk viscosity. In this paper there is proposed a mathematical model for the flow of high-temperature melts taking into account the nature of the short-range order in them and considering the second viscosity coefficient by the methods of statistical physics. Built distribution of melt flow rate based on the numerical experiments. An algorithm for the numerical integration of the hydrodynamic equations to predict the technological parameters of the filling metal melts.*

**Keywords:** viscosity, potential, computer simulation, melt, the hydrodynamic equations.

### Introduction

The method of computer simulation is considered as one of the most constructive methods for studying physical properties of melts. This is explained by a large theoretical and applied value of the information obtained with respect to the transfer coefficients, in particular, bulk and shear viscosities. There has been compiled a program for the numerical solution of equations of hydrodynamics for metal melts. There has been tested a program for solving the Dirichlet problem for the Poisson equation. Based on the theoretical studies carried out there have been calculated parameters determining the relationship between viscosity and interatomic potential. The relationships found permit determine the average values of any physical parameters, in particular, the values of shear and bulk viscosities. Scientific novelty - correlation functions viscosity justified in terms of the quantum-statistical method. The interrelation between the correlation functions with the radial distribution. The numerical scheme, which has good convergence for hydrodynamics equations melts. Built regularization source systems of differential equations by approximating the incompressible melt. Galerkin method is implemented, ensuring the correctness of the study of boundary value problems for an incompressible viscous flow both numerically and analytically.

### 1. Theoretical part

The methods of quantum statistical physics make it possible to express the coefficients of shear and bulk viscosities by means of correlation functions [1, 2]. This makes it possible to reveal the physical nature of the structure of matter through the operators of the second quantization, so that a powerful apparatus of quantum physics can be connected for the studies. One of the most constructive methods for studying physical properties of melts is computer simulation.

Let us consider one of the variants of splitting hydrodynamic equations with reference to calculation of the melt flow in a flat channel in accordance with Figure 1. Such a melt flow can be described by the following equations of the dimensionless form:

$$\frac{\partial u}{\partial x} + \frac{\partial v}{\partial y} = 0, \quad (1)$$

$$\frac{\partial u}{\partial t} + \frac{\partial u^2}{\partial x} + \frac{\partial uv}{\partial y} + \frac{\partial p}{\partial x} = \frac{1}{\text{Re}} \left( \frac{\partial^2 u}{\partial x^2} + \frac{\partial^2 u}{\partial y^2} \right), \quad (2)$$

$$\frac{\partial v}{\partial t} + \frac{\partial v^2}{\partial y} + \frac{\partial uv}{\partial x} + \frac{\partial p}{\partial y} = \frac{1}{\text{Re}} \left( \frac{\partial^2 v}{\partial x^2} + \frac{\partial^2 v}{\partial y^2} \right), \quad (3)$$

where  $\text{Re} = \rho u_0 H / \mu$ ,  $H$  – is the channel width,  $u_0$  – is velocity,  $\rho$  – is density,  $\mu$  – is melt viscosity.

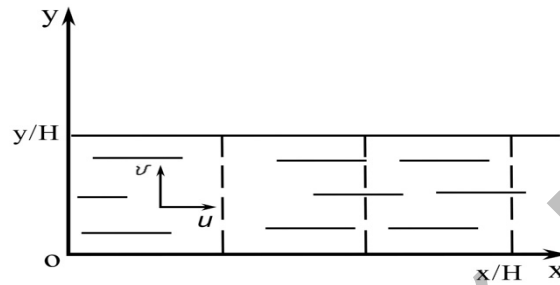

**Fig.1.** Model of the melt flow in a flat channel

Equations (1) – (3) are integrated at the following initial boundary conditions:

$$\text{at } t = 0, \quad 0 \leq x \leq \frac{\ell}{H}, \quad 0 \leq y \leq 1: \quad u = 1, v = 0, p = p_0,$$

$$\text{at } t > 0, x = 0, 0 \leq y \leq 1: \quad u = 0, v = 0, p = p_0,$$

$$\text{at } t > 0, x = \frac{L}{H}, 0 \leq y \leq 1: \quad \frac{\partial u}{\partial x} = \frac{\partial v}{\partial x} = 0, \frac{\partial p}{\partial x} = -\beta,$$

$$\text{at } t > 0, y = 0, y = 1, 0 \leq x \leq \frac{L}{H}: \quad u = 0, v = 0, \frac{\partial p}{\partial y} = \frac{1}{\text{Re}} \frac{\partial^2 v}{\partial y^2},$$

where  $\beta$  – is the preset pressure gradient,  $\ell$  – is distance from the input to the bench,  $L$  – is the channel full length.

Equations (1) - (3) depend on  $t$  and can be solved relative to  $u, v$  with the help of known numerical methods. But pressure  $p$  is given implicitly, since it does not enter the equations in the form of a derivative with respect to  $t$ . To exclude this let us write down equation of continuity (1) in the following form:

$$\frac{\partial w}{\partial t} + \frac{\partial u}{\partial x} + \frac{\partial v}{\partial y} = 0,$$

where  $w = p + \frac{1}{2}(v^2 + u^2)$  according to the Bernoulli's law.

Then equations (1) – (3) can be reduced to the following two independent systems of equations (4) and (5) that are given below for consideration:

$$\begin{cases} \frac{1}{2} \frac{\partial w_1}{\partial t} + \frac{\partial u}{\partial x} = 0 \\ \frac{1}{2} \frac{\partial u}{\partial t} + \frac{\partial u^2}{\partial x} + \frac{\partial p}{\partial x} = \frac{1}{\text{Re}} \frac{\partial^2 u}{\partial x^2} \\ \frac{1}{2} \frac{\partial v}{\partial t} + \frac{\partial uv}{\partial x} = \frac{1}{\text{Re}} \frac{\partial^2 v}{\partial x^2}, \end{cases} \quad (4)$$

$$\begin{cases} \frac{1}{2} \frac{\partial w_2}{\partial t} + \frac{\partial v}{\partial y} = 0 \\ \frac{1}{2} \frac{\partial v}{\partial t} + \frac{\partial v^2}{\partial y} + \frac{\partial p}{\partial y} = \frac{1}{\text{Re}} \frac{\partial^2 v}{\partial y^2} \\ \frac{1}{2} \frac{\partial u}{\partial t} + \frac{\partial uv}{\partial y} = \frac{1}{\text{Re}} \frac{\partial^2 u}{\partial y^2}, \end{cases} \quad (5)$$

where  $w_1 = p + \frac{u^2}{2}$ ,  $w_2 = p + \frac{v^2}{2}$ .

Thus, these two systems of equations allow simulating the melt flow in a flat channel. To solve these systems let's proceed as follows: for given initial conditions system of equations (4) is solved at  $y = \text{const}$  for a half-time. The data obtained in this case are used as initial conditions for integrating system of equations (5) at  $x = \text{const}$  for the next half-time. At the end of the procedure the obtained data are accepted as the final result. It should be noted that here also it is necessary to split the boundary conditions.

We represent the split boundary conditions in our case for system (4):

$$\begin{aligned} \text{at } x=0: & \quad u=1, v=0, p=0, \text{ for } y, \\ \text{at } x=\frac{L}{H}: & \quad \frac{\partial u}{\partial x} = \frac{\partial v}{\partial x} = 0, \frac{\partial p}{\partial x} = -\beta, \text{ for } y, \\ \text{at } x=\frac{\ell}{H}: & \quad u=0, v=0, \frac{\partial p}{\partial x} = \frac{1}{\text{Re}} \frac{\partial^2 u}{\partial x^2}, \text{ for } 0 \leq y \leq \frac{L}{H}. \end{aligned}$$

Then for system (5):

$$\begin{aligned} \text{at } y=\frac{L}{H}, 0 \leq x \leq \frac{\ell}{H}: & \quad u=0, v=0, \frac{\partial p}{\partial y} = \frac{1}{\text{Re}} \frac{\partial^2 v}{\partial y^2}, \\ \text{at } y=0, \frac{\ell}{H} \leq x \leq \frac{L}{H}: & \quad u=0, v=0, \frac{\partial p}{\partial y} = \frac{1}{\text{Re}} \frac{\partial^2 v}{\partial y^2}, \\ \text{at } y=1, 0 \leq x \leq \frac{L}{H}: & \quad u=0, v=0, \frac{\partial p}{\partial y} = \frac{1}{\text{Re}} \frac{\partial^2 v}{\partial y^2}. \end{aligned}$$

## 2. Modeling of the melt flow in the inclined gutter

Now let's consider the melt flow in the inclined gutter. A general form of the equations is given in [3]. For a particular design they can be treated and written down as follows. Let's direct the  $Oz$  axis along the gutter axis assuming that the gutter design is infinitely long and the melt flow is directed along the gutter axis so that only one of the three velocity components  $u, v, w$ , remains. Therefore, let the melt flow be isothermal, then the density  $\rho$  and the viscosity coefficient  $\mu = \text{const}$ .

Therefore, the Navier-Stokes equations can be written in the form:

$$-\frac{1}{\rho} \frac{\partial p}{\partial x} = 0, -\frac{1}{\rho} \frac{\partial p}{\partial y} = 0, w \frac{\partial w}{\partial z} = -\frac{1}{\rho} \frac{\partial p}{\partial z} + \gamma \left( \frac{\partial^2 w}{\partial x^2} + \frac{\partial^2 w}{\partial y^2} + \frac{\partial^2 w}{\partial z^2} \right), \frac{\partial w}{\partial z} = 0. \quad (6)$$

Thus, as can be seen from system of equations (6), velocity represents a function only of the  $x, y$ , coordinates. In addition, the pressure function  $p$  is a function of  $z$ . On the basis of (6) we obtain the equation:

$$\frac{dp}{dz} = \mu \left( \frac{\partial^2 w}{\partial x^2} + \frac{\partial^2 w}{\partial y^2} \right). \quad (7)$$

The right part of (7) represents a function of  $x, y$ , and the left part is a function of  $z$ . From the basic aspects of hydrodynamics it follows:

$$\frac{dp}{dz} = -\frac{\Delta p}{\ell},$$

where  $\Delta p$  – is pressure drop on the arbitrarily selected section,  $\ell$  – is the gutter length.

In addition, due to the presence of the melt free surface in the gutter, pressure is equal to the atmospheric pressure [4]. Since the gutter is inclined to the horizon at some angle  $\alpha$ , there appears a volume force which projection on the  $Oz$  axis is equal to  $F_z = g \sin \alpha = \frac{\Delta p}{\ell}$ . Then equation of motion (7) in the  $Oz$  direction becomes:

$$\mu \left( \frac{\partial^2 w}{\partial x^2} + \frac{\partial^2 w}{\partial y^2} \right) + \rho g \sin \alpha = 0. \quad (8)$$

To solve this equation we need some boundary conditions. These conditions will be determined by the adhesion of the melt to the bottom of the gutter and the absence of friction on the melt free surface. We denote the depth of the flow as  $h_1$ , the width of the gutter as  $h_2$ . Then the boundary conditions of the problem are written as follows:

$$w = 0 \text{ at } y = 0, \quad \frac{\partial w}{\partial y} = 0 \text{ at } y = h_1, \quad \frac{\partial w}{\partial x} = 0 \text{ at } x = h_2. \quad (9)$$

Thus, equation (8) with boundary conditions (9) will describe the process of the melt flow in concrete gutter type structures. This model is made for the smelting equipment of the SCR – 2000 line which diagram is presented in accordance with Figure 2.

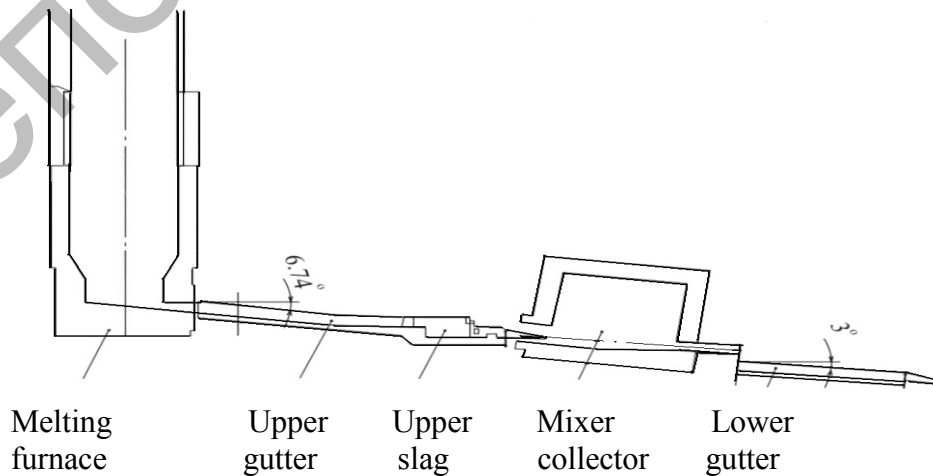

**Fig.2.** Diagram of the SCR – 2000 line melting equipment arrangement

The calculations have been performed for a lower gutter with the inclination angle of  $3^\circ$ . The section of the lower gutter is presented in accordance with Figure 3 and shows the level of the melt.

Numerical parameters have been determined according to the following calculations: the segment area is  $S = \frac{[lr - a(r - h)]}{2}$  where  $l$  – is the arc length,  $a$  – is bisecant,  $h$  – is the segment sagitta:

$$a = 83\text{mm}, h = 18\text{mm}, l \approx \sqrt{a^2 + (16h^2/3)} = \sqrt{83^2 + (16 \cdot 18^2/3)} = 92,8\text{mm}.$$

It follows that:

$$S = \frac{\left[ 92,8 \cdot \frac{115}{2} - 83 \left( \frac{115}{2} - 18 \right) \right]}{2} = 1029\text{mm}^2.$$

Then, the second flow rate of the melt is:  $Q = 3.61 \frac{\text{kg}}{\text{s}}$ . Taking this into account, it is possible to determine the average melt flow velocity that is equal to  $v_{cp} = 0.45 \frac{\text{m}}{\text{s}}$ .

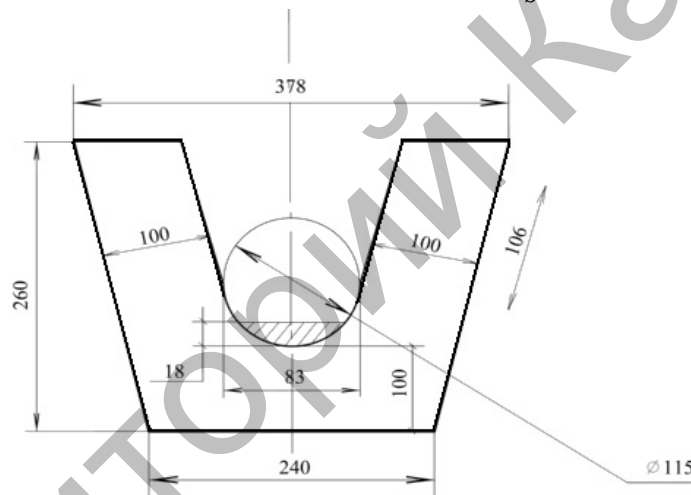

Fig.3. Lower gutter section

The constant steps  $\Delta x = \Delta y = 0,02$  were used in the calculations. The time step in the calculations was selected to be equal to  $\Delta t = 0,001$ . The established results for velocity profiles  $v$  and  $u$  of the melt flow in a flat channel are shown in Figure 4.

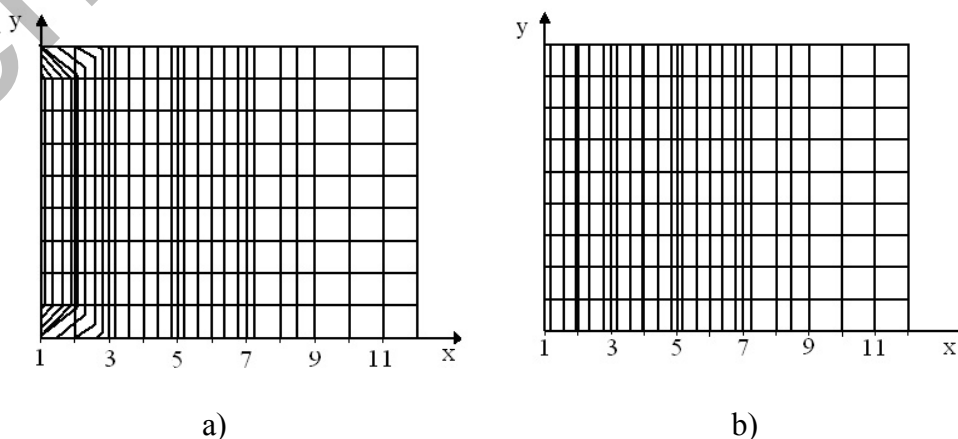

Fig.4. Profiles of: a) – transverse  $v$  and b) – longitudinal  $u$  velocities

Achieving the steady flow required 3000 steps. The analysis of the results shows the following facts regarding the accuracy of the numerical calculations used. Firstly, when calculating the flow in the input grid cell, the computational error leads to the mass loss of 8-9%. As soon as we reduce the cell size by 10 times, the mass loss is reduced to 4-6%. When calculating with great accuracy, taking into account the features of the boundary conditions, a special numerical scheme was required.

Secondly, the maximum velocity in the central current line is equal to  $0.63 \frac{m}{s}$ .

This value is approximately 15% higher than the experimental value. The obtained results show that the proposed computational scheme is quite economical and can be used without special problems to calculate the flow for sufficiently small Reynolds numbers. The analysis of the data obtained shows that replacing the continuity condition with an equation for Poisson type pressure, as done in [3], leads to a numerical scheme free from a complicated computational procedure. As it is shown in [5], molten metals can be represented as two-component liquids that consist of ionic and electronic components. This statement permits to apply the virial theorem, thereby assessing the part of the pressure associated with the dynamics and interaction of the ion subsystem, i.e.:

$$p_u = \frac{1}{3\Omega} \left\{ 2K - \sum_{i<j} R_{ij} \frac{\partial V}{\partial R_{ij}} + R_S \frac{\partial V(R_{ij})}{\partial R_S} \right\},$$

where  $K$  is kinetic energy.

At this full pressure is determined by the sum of the ion gas pressure  $p_u$  and the electronic gas pressure  $p_{eg}$ , i.e.:  $p = p_u + p_{eg}$ .

The ways of their calculation are shown in [5]. The ion gas pressure  $p_u$  will be written down in an integral form taking into account the radial distribution function of the atoms  $R(r)$ . Then for  $p_u$  we obtain:

$$p_u = \frac{1}{6\Omega} \int_0^{\infty} R(r) \left[ R \frac{\partial V}{\partial R} + R_S \frac{\partial V}{\partial R_S} \right] dR + \frac{KT}{\Omega}.$$

In this case, it is necessary to pay special attention to the  $\frac{\partial V}{\partial R_S}$  behavior because  $V(R, R_S)$  is a function of the distance, as well as the  $\Omega = \Omega(R_S)$  function that results from the dielectric constant. It is known that the dielectric constant characterizes indirect interaction of ions from the screening electronic subsystem. Thus, the equilibrium state must be considered simultaneously for both subsystems, ionic and electronic.

On the basis of the "sum of compressibility rules" there can be determined how much the model of the molten system is self-consistent. If the value of the volume modulus is determined correctly, the reciprocal value is equal to compressibility. Compressibility is important when considering physical and chemical properties of molten metals. On the basis of [5] it can be asserted that in a crystalline substance the bulk modulus of elasticity is equal to the energy derivative by volume. The static modulus must be coordinated with the dynamic modulus. The dynamic modulus is calculated from the phonon dispersion relation in the long-wave approximation. Consequently, it is closely related to the interatomic interaction. This assertion is the essence of the compressibility rule and is well verified for crystalline metals [5]. Further studies have shown that the sum rule is not completely satisfied for the model of metals constructed by perturbation theory in the second order in terms of empirical potentials. Then the terms of the third and fourth orders appearing in the dynamic matrix give the second-order contribution. The discrepancy results from inclusion of these contributions only when calculating static module and neglecting them when calculating dynamic module.

As it is shown in [6], the inclusion of the higher terms of expansion in the construction of the dynamic matrix approximates the experimental data to theoretical data. This is logical, since the

higher terms of expansion correspond to dispersion interaction. In addition, it can be established that neglecting the dependence of the pair potentials on density results in the dynamic volume modulus  $\beta_{din}$  being the one calculated in the computer model. Taking into account self-consistency, the static modulus can be equal to the dynamic modulus. Calculations carried out for tin have shown that for experimental reconciling the calculated static modulus  $\beta_{st}$  it is necessary to vary experimentally the Hartree energy. But with such a variation the dynamic modulus  $\beta_{din}$  that is well coordinated with the experiment turns out to be too high. A possible explanation for this is that the terms of the third and fourth orders become more important in the dynamic matrix in the region for small  $q$ . In this case, in order to maintain the agreement with the experiment, it is necessary to modify the pseudopotential in the indicated region. In this case, the variation of the Hartree energy will correspond to the modified pseudopotential. This is evidenced by the fact that the values obtained for tin turned out to be equal to  $3.5 \cdot 10^{-11} \frac{m^2}{N}$ .

The data are in good agreement with the experimental data within 10%. These assumptions make it possible to estimate the relaxation time of structural viscosity (that is, bulk viscosity). According to Ya.I. Frenkel, the time of the settled life of an atom is  $t = 10^{-11} s$ . This value agrees well with the relaxation time of bulk viscosity found. According to the hole theory, it can be assumed that volume deformation of the melt is composed of two types of deformation. The first is instantaneous and delayed. The second is associated with the changing number of holes during the melt motion. The delayed part of the compressibility can be calculated from the formula:

$$\beta_{del} = \frac{\Delta V^2}{VRT} e^{-\Delta H/RT},$$

where  $\Delta V$  – is a change of the hole volume,  $\Delta H$  – is the enthalpy increment due to the hole formation.

Then, if the delayed part of compressibility is known, then by the formula given in [7], it is possible to determine bulk viscosity:

$$\mu_V = \frac{t}{\beta_0},$$

where  $\beta_0$  is equilibrium compressibility,  $t$  is the delay time.

### 3. Results and discussion

Thus, knowing the  $\beta_0$  value, it is possible to determine the value of bulk viscosity, the nature of the copper melt flow is completely determined by the presence of the melt viscosity, the theoretical and experimental [8] values of which are presented in accordance with Figure 5. Taking into account shear and bulk viscosities of the copper melt, the distribution of flow velocities in the lower gutter at temperatures of 1358 K, 1398 K, 1438 K, 1478 K, 1518 K, 1558 K, 1598 K, 1638 K in projections onto the XOY plane, as well as in the XYZ space are presented in accordance with Figures 6-13 and Appendix B. It can be seen that the lines of constant velocity, isovels, vary from  $0.64 \frac{m}{s}$  up to  $0.01 \frac{m}{s}$ .

$$\mu_{sh} = \rho_0 k_B T \left[ 1 + \frac{4}{15} I_1 + \frac{1}{15} I_2 \right] \tau, \quad \mu_V = \rho_0 k_B T \left[ \frac{3}{5} - \frac{2}{9} I_1 + \frac{1}{9} I_2 \right] \tau - k_0 \tau, \quad (10)$$

Moreover, the maximum flow velocity is reached at the surface itself, and at the bottom of the gutter it is practically zero, that is completely consistent with the conditions of equations (6), (7).

The average value of the isovelocity contour is approximately equal to the average melt flow rate

$$v \approx 0,40 \frac{m}{s}.$$

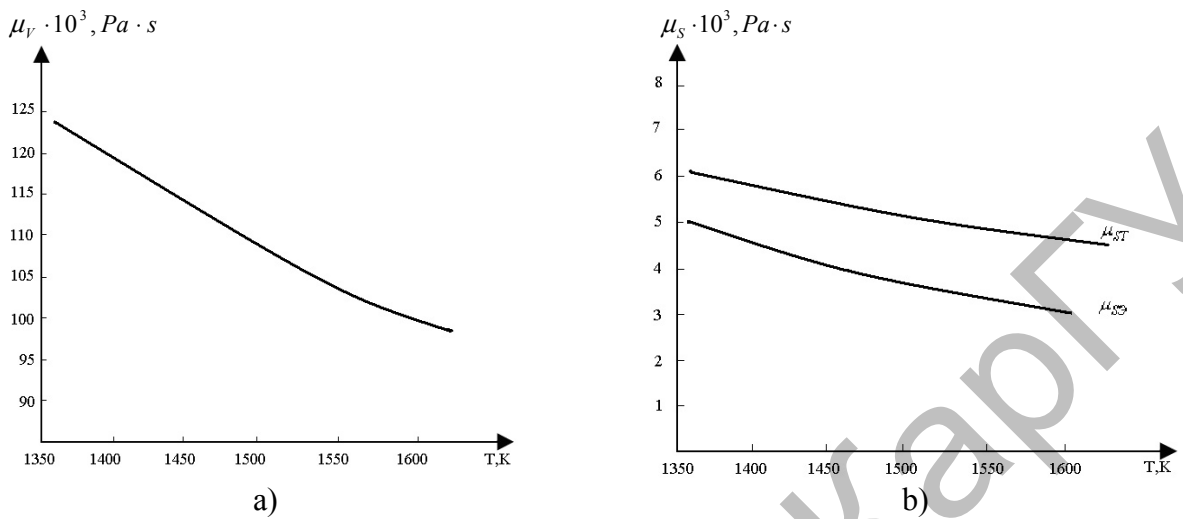

**Fig.5.** a) Theoretical value of bulk viscosity; b) experimental  $\mu_{S\Omega}$  [8] and theoretical values of shear viscosity according to formulas (10).

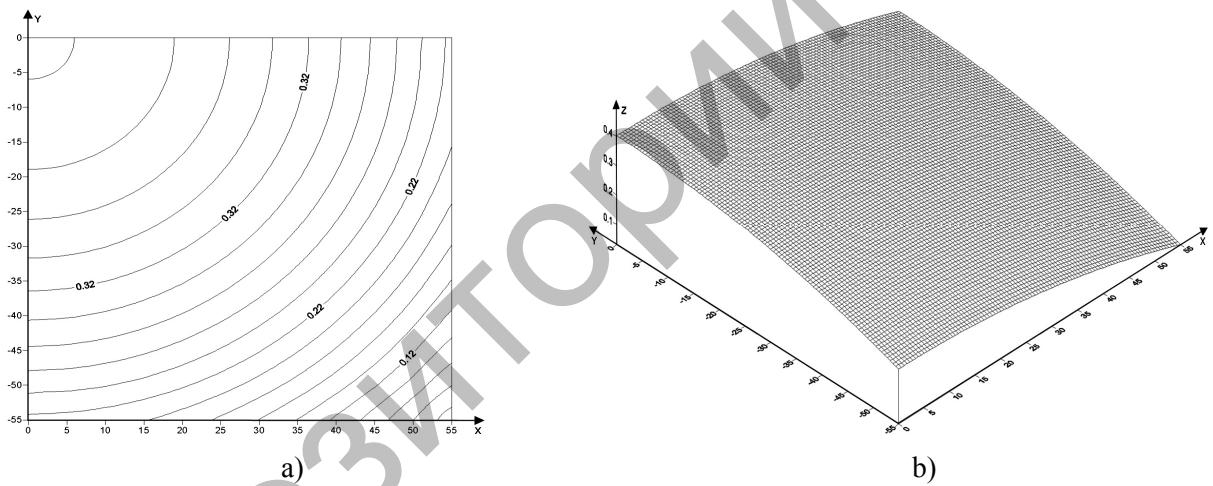

**Fig.6.** Velocity contour: a) and surface; b) at 1358 K

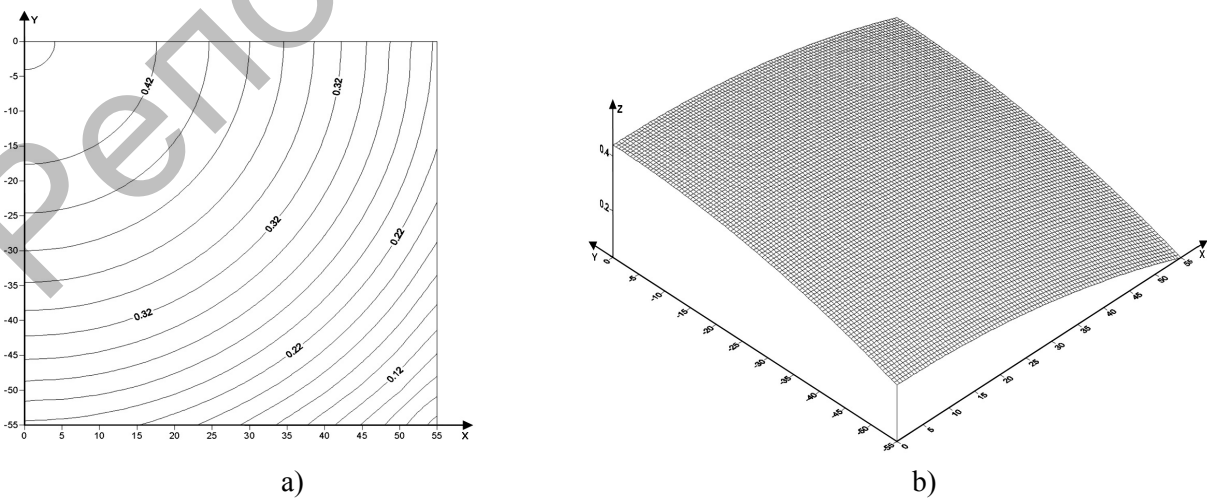

**Fig.7.** Velocity contour: a) and surface; b) at 1398K

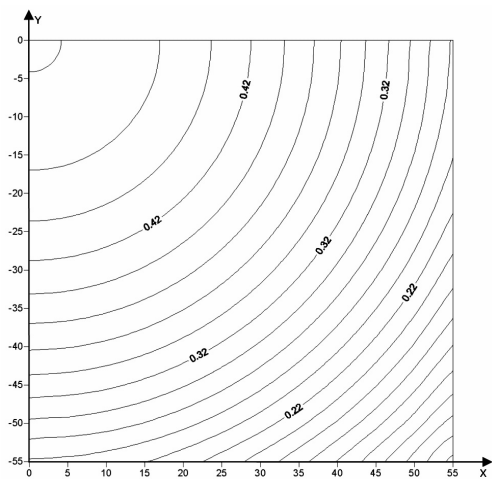

a)

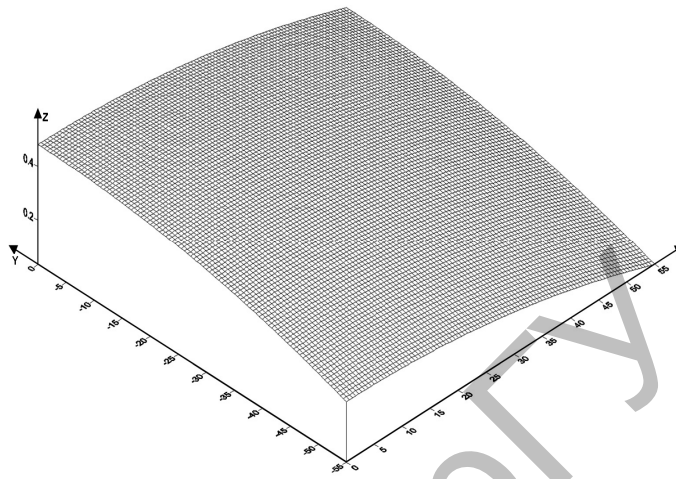

b)

Fig.8. Velocity contour: a) and surface; b) at 1438K

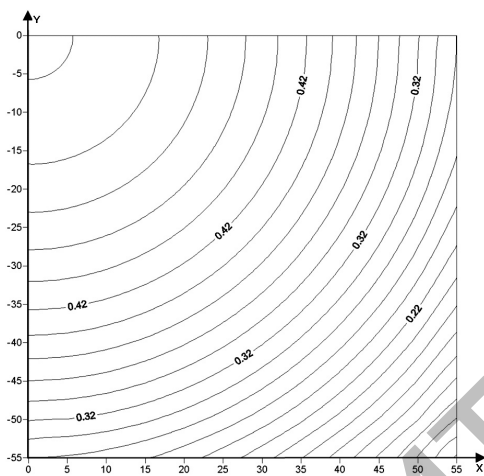

a)

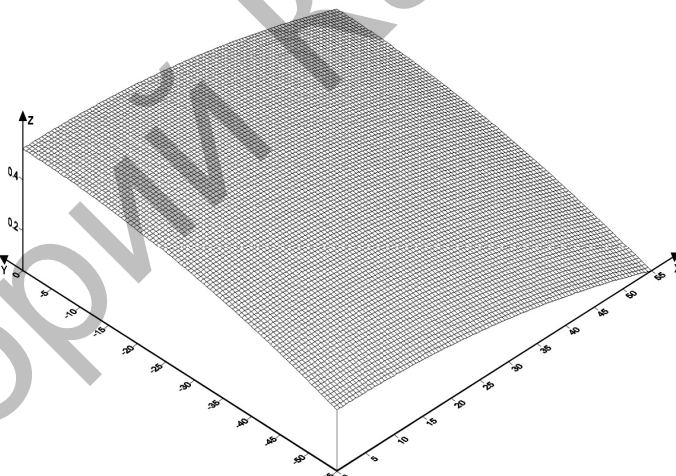

b)

Fig.9. Velocity contour: a) and surface; b) at 1478K

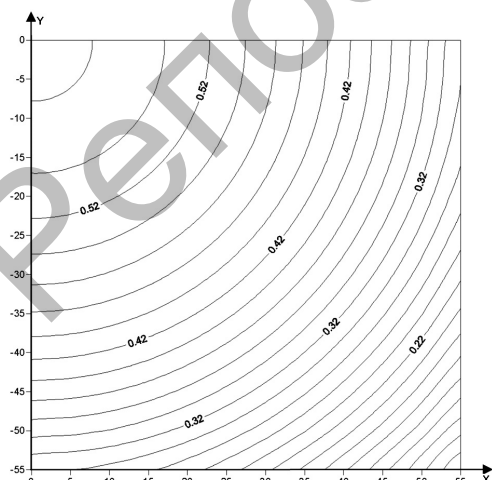

a)

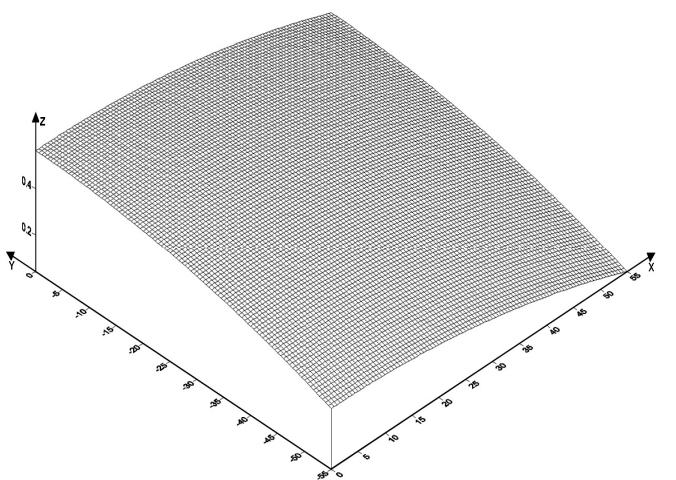

b)

Fig.10. Velocity contour: a) and surface; b) at 1518K

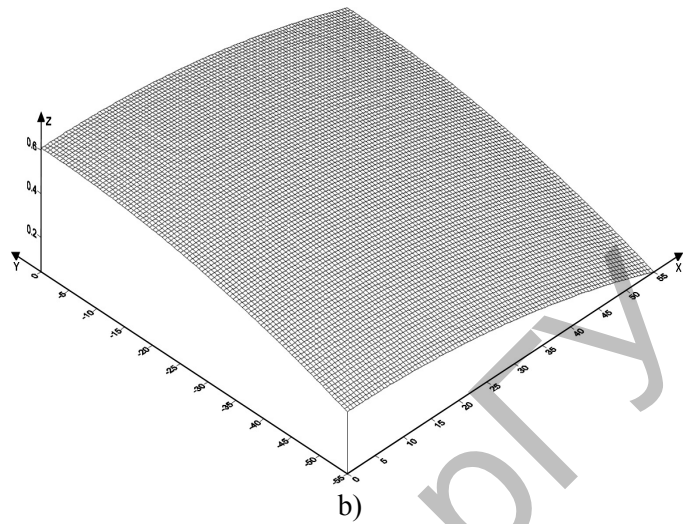
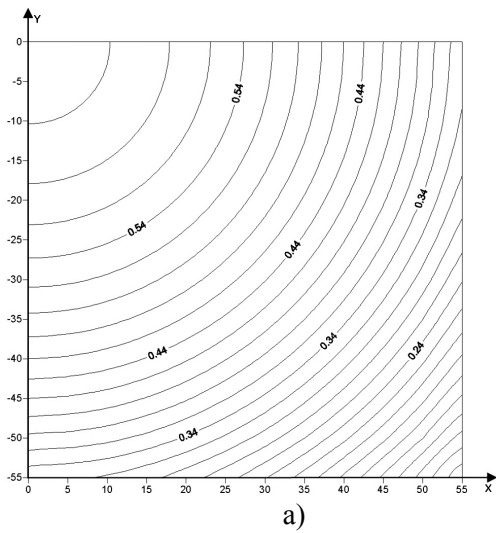

Fig.11. Velocity contour: a) and surface; b) at 1558K

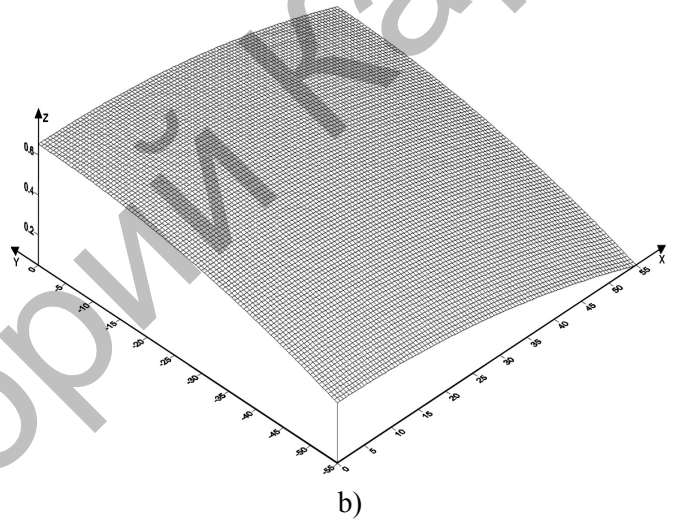
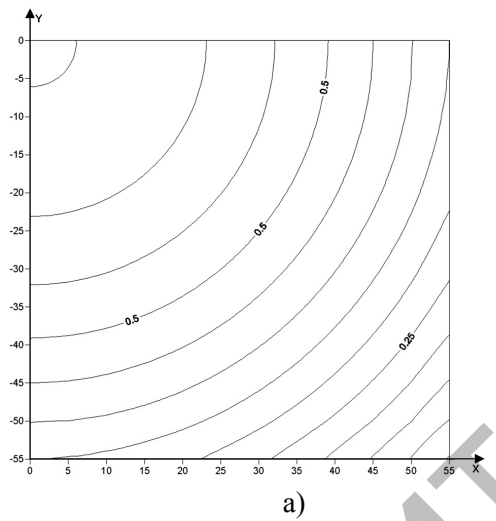

Fig.12. Velocity contour – a) and surface – b) at 1598K

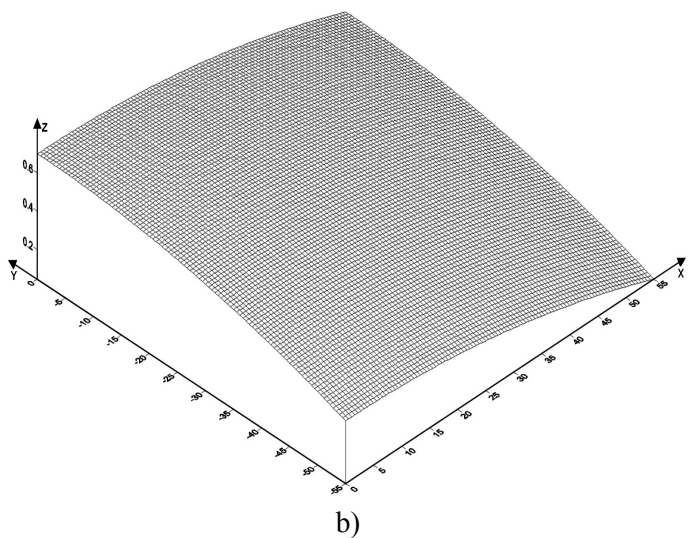
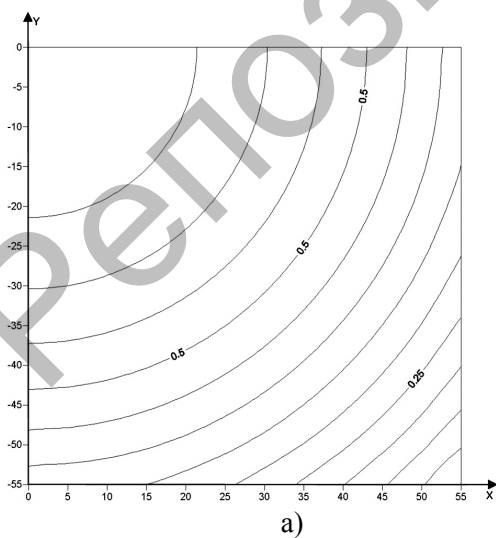

Fig.13. Velocity contour: a) and surface; b) at 1638K

The calculation step for all temperatures remained constant. According to the logic of constructing isovelocity contours, the number of them must remain constant. But in this case the situation is different. The number of contours at the corresponding temperatures is as follows:

T, K	1358	1398	1438	1478	1518	1558	1598	1638
n – number of contours	19	21	23	24	26	28	12	12

These data show that the number of contours passes through the maximum at the temperature of 1558 K. At lower temperatures, for example at 1358 K, as well as at high temperatures, for example at 1598 K, the velocity distribution is not so dense. This may be due to the fact that the melt near the melting point is not homogeneous due to the existence of formation clusters in it. Heterogeneity at temperatures of 1598 K and above is associated with the thermal loosening of the molten metal structure and is not technologically expedient, since it leads to forming mechanical defects of finished products.

### Conclusion

This method of calculation can be used to calculate the motion of a copper melt during filling from converters, from anode furnaces, as well as in the line of continuous casting and rolling in the production of copper wire rod. It is noteworthy that this temperature is close to the optimum copper pouring temperature at JV Kazkat in Zhezkazgan [9].

Thus, theoretical calculations of the optimum flow temperature (viscosity) in the equilibrium system taking into account the melt velocity are consistent being in the interval of the 1423-1558 K optimum, close to the real melting temperatures in industrial conditions.

### REFERENCES

- 1 Regel A.R., Glazov V.M. Physical properties of electron melts. Moscow, 1980, 296 p. [in Russian]
- 2 Akhiezer A.I., Petleminsky S.V. Methods of statistical physics. Moscow, RFM Science, 1977, 368 p.
- 3 Kazhikenova S. Sh. Monitoring of Process Flow Diagrams in the Production of Ferrous Metals. *Refractories and Industrial Ceramics*. Springer Link, 2016. Vol.57, No. 4, pp. 360 – 363. <http://link.springer.com/article/10.1007/s11148-016-9984-8>
- 4 Maksimov Ye.V, Torgovets A.K. Mechanics of liquids, gases and friable medium. Almaty, RIC, 1997, 254 p. [in Russian]
- 5 Suleimenov T. *Quantum chemical nature of short-range order in disordered systems*. Thesis for the degree of Doctor of Chemistry. Karaganda, DGP HMI named after Zh. Abishev, 2004, pp. 191.
- 6 Yan X. Wei L, Lei Yao, Xin Xue, Yanbin Wang, Gang Zhao, Juntao Li, Qingyan Xu. Numerical Simulation of Meso-Micro Structure in Ni-Based Superalloy During Liquid Metal Cooling. *Proceedings of the 4th World Congress on Integrated Computational Materials Engineering (ICME 2017). The Minerals, Metals & Materials Series*. 2017, pp. 249-259 [https://doi.org/10.1007/978-3-319-57864-4\\_23](https://doi.org/10.1007/978-3-319-57864-4_23)
- 7 Lobodyuk, V.A., Koval', Y.N. & Pushin, V.G. Crystal-structural features of pretransition phenomena and thermoelastic martensitic transformations in alloys of nonferrous metals. *The Physics of Metals Metallography*. 2011, Vol.111, pp. 165 – 189. <https://doi.org/10.1134/S0031918X11010212>.
- 8 Shpilrain E.E., Fomin V.A., Skovorodko S.N., Sokol G.F. *Studying viscosity of liquid metals*. Moscow, Nauka, 1983, 244p. [in Russian]
- 9 Kazhikenova S.Sh., Shaltakov S.N., Issagulov A.Z. *Physical and chemical aspects of theory of metallurgical processes*. Monograph. Karaganda. KSTU Publisher, 2010, 257 p. [in Russian]