

ELECTROHYDRAULIC METHOD FOR PROCESSING OF THE PHOSPHORUS CONTAINING SLUDGES

Nussupbekov B.R., Sakipova S.E., Edris A., Khassenov A.K., Nussupbekov U.B., Bolatbekova M.

E.A. Buketov Karaganda University, Karaganda, Kazakhstan, bek_nr1963@mail.ru

The creation of an effective method for processing toxic waste from phosphorus production, as well as the suppression of the sludge formation process itself, are still relevant. This article discusses a method for processing toxic phosphorus sludge using electro hydraulic impulses. The phosphorus sludge structures before and after treatment with electric discharges are shown. The histograms of the distribution of phosphorus sludge particles by size after processing with electrohydraulic pulses are considered. It's established the content of large droplets is low and on the contrary the high content of droplets of small size in the phosphorus sludge at the electro hydraulic treatment result.

Keywords: phosphorus, sludges, electro-hydraulic processing, structure, pulses number, dispersed composition, toxic waste

Introduction

The development of an effective method for extracting phosphorus from phosphorus sludges and processing the residues into safe waste is still one of the urgent problems due to their high toxicity. At large phosphorus plants, up to a thousand tons of phosphorus sludge is produced, and large mechanized installations are being built to process it [1-7]. The toxic and flammable properties of phosphorus, the storage of sludge in storage tanks worsen the ecological situation in the surrounding area, and also require free space and large investments. The increasing needs for phosphoric salts and feed phosphates are one of the reasons for the intensive development of the electrothermal method of phosphorus production [1].

The main raw materials for the electrothermal phosphorus production are the phosphorites mined from the deposits of Karatau. Currently, in the city of Zhanatas, the chemical complex of «EuroChem» is operating, where mining complexes have been built including units of medium crushing and dry grinding [2]. The phosphorites of the Karatau basin contain low useful components, approximately 25%, but a high content of impurities. At the same time, the specific weight of the necessary products is about 24.7% [3], and up to 30% of phosphorus was produced in the form of phosphoric sludge [4]. Therefore, the use of a pulsed high-voltage discharge to extract marketable products from sludge is an urgent task for the industry, and the introduction of energy-saving technologies makes it possible to increase production efficiency [6].

Phosphorus plants in Kazakhstan mainly use two methods of sludge processing: stripping of phosphorus with water vapor (distillation method) and direct combustion of sludge in special furnaces to obtain sludge phosphoric acid [7]. The first method is characterized by a low intensity of sludge processing when obtaining low-quality phosphorus, the second - by the low quality of the resulting product. There are also several chemical methods for extracting phosphorus from water sludge. The phosphorus sludge is separated into an aqueous suspension containing suspended particles of phosphorus and contaminants, and coarse solid particles. The reagent is added. The coarse solids are mixed with hot water to melt the phosphorus sludge in them, which is then separated from the inert solids. The solids are heated to burn off any residual elemental phosphorus. Molten phosphorus sludge is mixed with a solution of chromic acid to extract phosphorus as a separate phase. Then they again act with other reducing agents. The reaction mass is filtered and then in the form of a cake can be buried as safe waste.

Without listing all the features and details, we can conclude that almost all methods use exposure to the aquatic environment at high temperature and pressure. These effects can be provided by using the electrohydraulic (EH) method of processing phosphorus sludge. Let us consider some aspects of the application of an EH processing of the phosphorus sludge.

1. Method for processing phosphorus sludge using electro-discharge action

When using an electric discharge effect for the treatment of phosphorus sludge in an aqueous medium, the structure of its dispersed particles is destroyed, the shells of phosphorus droplets are destroyed, preventing the process of coalescence [8-11]. To implement this process, a high-voltage pulse is applied to the electrodes placed directly in the phosphorus sludge medium, which causes the development and implementation of an electric discharge in a liquid medium. In this case, all the energy stored in the capacitor bank almost instantly enters the working gap in the liquid and is released in the form of a short electric pulse of high power. Further, a high-pressure zone appears around the discharge channel. The liquid, having received acceleration from the expanding discharge channel, moves in all directions at high speed. At the site of the discharge formation, a cavitations are formed, which generates shock waves. Shock waves or compression waves act on phosphorus droplets surrounded by a shell of the mineral part of the sludge and organic impurities and destroy these shells. Drops of phosphorus free from the shielding shell settle, then in the process of coalescence (fusion) of phosphorus particles, the phosphorus sludge is separated into pure phosphorus and impurities.

It is possible to intensify the process of obtaining phosphoric acid from phosphorus sludge because the mineral shell of phosphorus particles is destroyed. Then phosphorus sludge with a strong stabilized structure is processed into an emulsion-suspension of phosphorus particles and solid mineral impurities cleaned from the shell. It should also be noted that in the EH processing method it is possible to adjust the parameters of the electric discharge (energy, power, number of pulses, pressure at the front of the shock wave, ect.) depending on the type of phosphorus sludge [10].

2. Experimental part

The experiments were carried out on a bench consisting of a thermostat, a measuring cell with a plane-parallel capacitor (Fig.1.), an impedance meter that measures the total resistance modulus and phase angle within the resistance range of $1 \div 10^7$ Ohm in the frequency range of $5 \div 10^8$ Hz. This instrument can be used to directly measure the inductance and capacitance of dispersed particles by measuring the reactance at various frequencies. To eliminate the effect of electrode polarization in the case of high conductivity of the test substance, measurements can be carried out by varying the distance between the electrodes [11].

On fig. 1 is the scheme of the measuring block into which the phosphorus sludge samples are placed. The bottom electrode 1 is grounded, and the top electrode 2 moves in the vertical-axial direction. To maintain the temperature regime, the sensors are placed in a thermostatically controlled metal cup 4, the body 3 is made of fluoroplast-4. Electrode 2 is insulated with a sleeve 5. There are branch pipes 6 on the glass for connection to a thermostat.

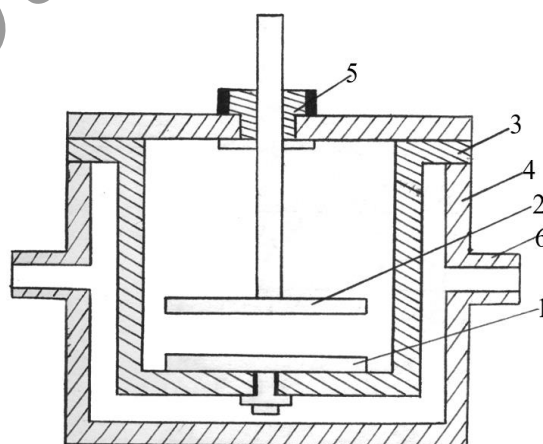

Fig.1. Measuring block of a laboratory electro-hydraulic installation.

In the experiments, the values of the particles electric capacitance were obtained for various EH processing parameters. These results obtained can be used to calculate the energy losses at the stage of formation of a high-voltage discharge in the aqueous medium of phosphorus sludge. It is also possible to determine the optimal values of the parameters of the electric discharge pulse for sludges of various

compositions. Practice shows that in the process of phosphorus production slimes of various composition are formed and the choice of a reliable method for their processing is impossible without a detailed analysis of the properties, structure and dispersed composition of slimes.

3. Results and discussion

The structure was analyzed using a scanning microscope. Data on changes in the microstructure as a result of electropulse processing have been obtained. Using EH processing, you can change the number of discharges. Now consider microscopic analysis and histograms of the distribution of phosphorus sludge particles by size after processing with electrohydraulic pulses. For microscopic studies, a hermetically sealed preparation with a thin section of solidified «monolithic» phosphoric slime or a layer of granular slime was placed in an «Epiquant» structural analyzer, examined visually and selectively photographed in transmitted light using a photo attachment. To complete the picture, microscopic studies of samples of phosphorus sludge with phosphorus content of 70%, 50%, 30% and the mineral part of the sludge were carried out. Microphotography of initial samples of sludge with a P_4 – 30% content before treatment with electric discharges was also performed (Fig.2). On the Fig. 3 shows microphotography of the sludge during settling after electric discharge treatment, and it can be seen from the predominance of large droplets that there is a process of micelle formation and phosphorus coalescence with its subsequent separated.



Fig.2. Microphotography of the initial sludge before treatment with electric discharges

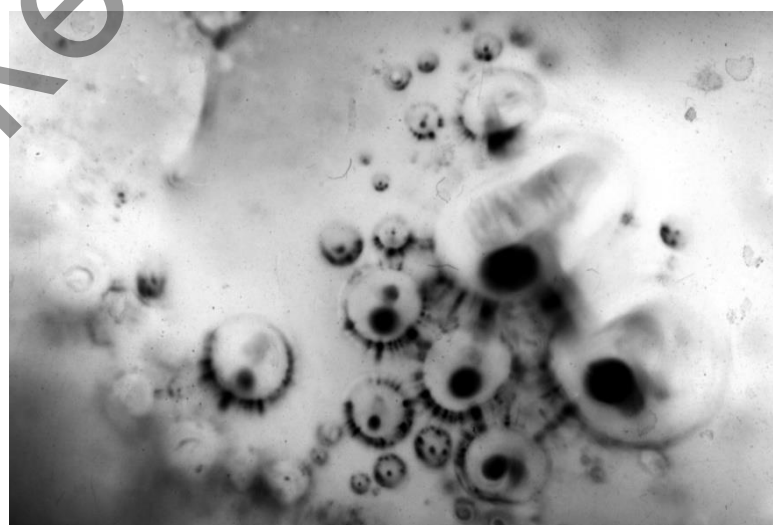

Fig.3. Microphotography of phosphorus droplets after treatment with electric discharges during micelle formation and coalescence

Figure 4 shows a microphotograph of the mineral part of the sludge after settling. Photoprints were used to determine the size distribution of phosphorus droplets by the method of A.G. Spector chords method, the volume fraction of phosphorus droplets in the sludge was determined by A. Rozival's linear method, and the specific surface area was determined by the random secant method for the space of S.A. Saltykov [1, 6].

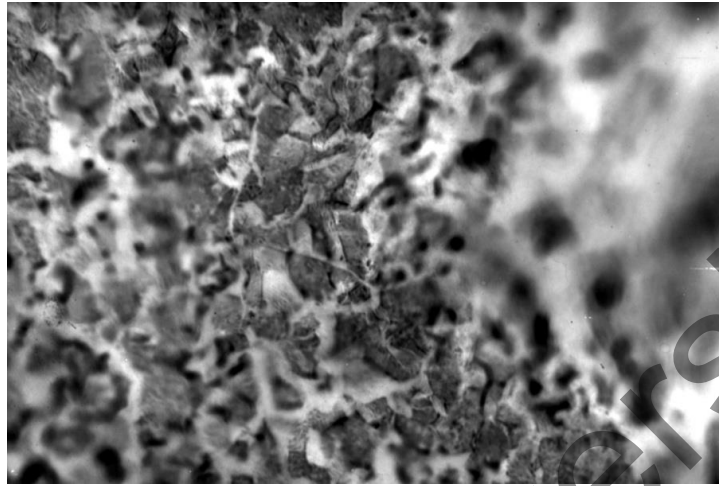

Fig.4. Microphotographs of the mineral part of the sludge after electric discharge treatment and sedimentation

A typical histogram obtained by microscopic analysis of the sludge is shown in figure 5. Dimensionless values of the number of dispersed sludge particles are plotted on the vertical axis n_i/n . Statistical processing of the analysis results showed that the most accurate description of the histogram is the differential distribution function that obeys the logarithmically normal distribution law.

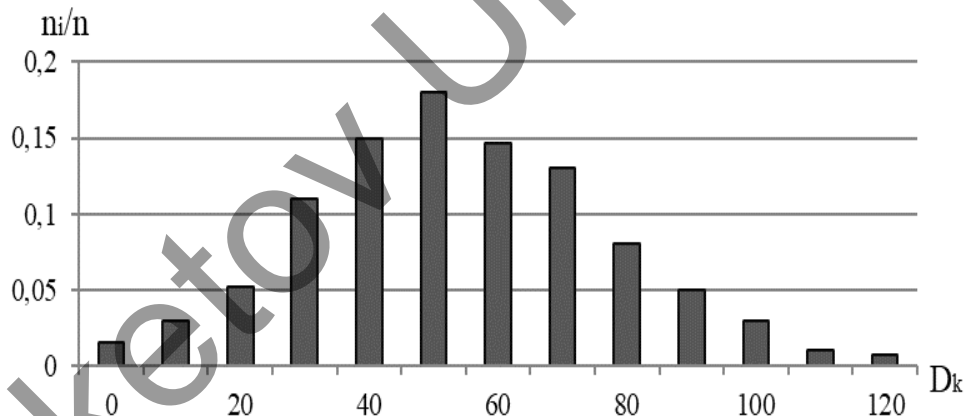

Fig.5. Typical histogram obtained by microscopic analysis of sludge.

In fact, larger droplets are aggregatively and sedimentally unstable, since the force of gravity becomes greater than the forces of flocculation interaction between the particles and the phosphorus drop, overcoming the structural and mechanical barrier, settles to the bottom of the vessel. Apparently, this is why the content of large droplets is low. On the contrary, the smaller the droplet diameter D_k , so they are stable and sedimentation stable, this explains the high content of droplets of small size.

All these factors determine the skewness of the histogram to the left of the maximum, which is characteristic for the logarithmically normal distribution law. Figure 6 shows a histogram of the size distribution of sludge particles after treatment with an electric discharge pulse of average power ($U_0=20$ kV, $C=0.15$ μ F). Figure 7 shows a histogram of the distribution of sludge particles after exposure to a more powerful high-voltage pulse ($U_0=30$ kV, $S=0.35$ μ F). A significant increase in the content of smaller droplets (0 – 40 microns) after exposure to a powerful discharge pulse, which indicates an intensive process of dispersion of phosphorus particles and the dependence of this process on the pulse parameters. During the shockwave effect on the phosphorus emulsion in water, the stabilizing shell of the phosphorus droplets is destroyed, after which, during the subsequent settling, the phosphorus droplets coalesce (merge), they settle,

and now the phosphorous sludge has an oil/water emulsion structure, that is, water droplets (the dispersed phase), the so-called reverse-type emulsion, are distributed in the dispersion medium of phosphorus. The phosphorus content in this type of sludge is more than 70%. Here the water droplets are already stabilized by a shell of organic and mineral impurities.

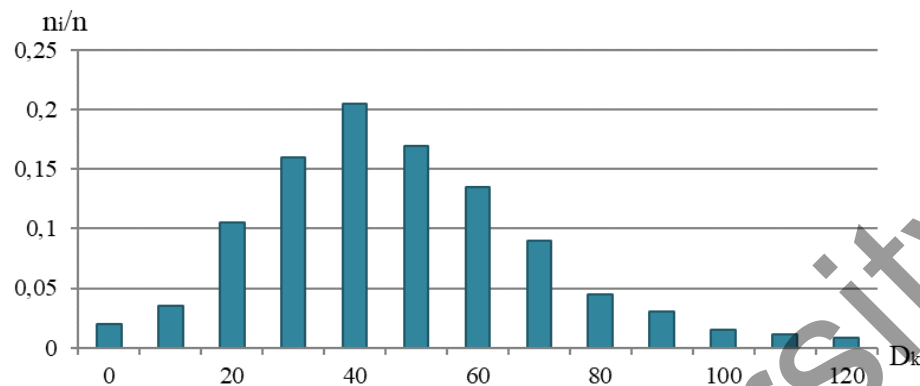

Fig. 6. The size distribution of sludge particles after treatment with an electric discharge pulse of average power.

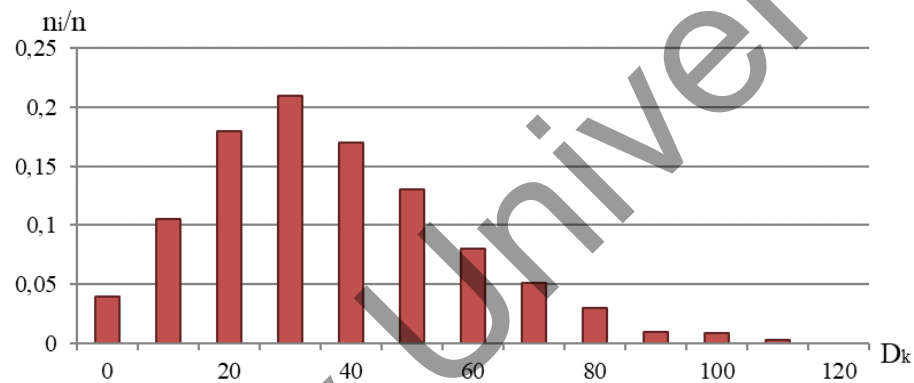

Fig. 7. The distribution of sludge particles after exposure to a powerful high-voltage pulse

Of particular interest are the dependences of the dispersed characteristics of phosphoric sludge on the parameters of processing pulses. In subsequent experiments, the value of the initial voltage varied in the range of 15÷40 kV, with the value of the interelectrode gap, mm-11. As can be seen, that the main factor determining the process of dispersion of phosphorus drops is the energy released in the discharge channel during the first half-period of the discharge current oscillation. This value, in turn, determines the value of the pressure amplitude at the front of the compression wave, which is the main tool for crushing phosphorus droplets. The dependence of the dispersed characteristics of phosphoric sludge on the number of processing pulses is studied. Figure 8 shows the dependence of the average diameter of the phosphorus sludge particles D on the number of processing pulses N .

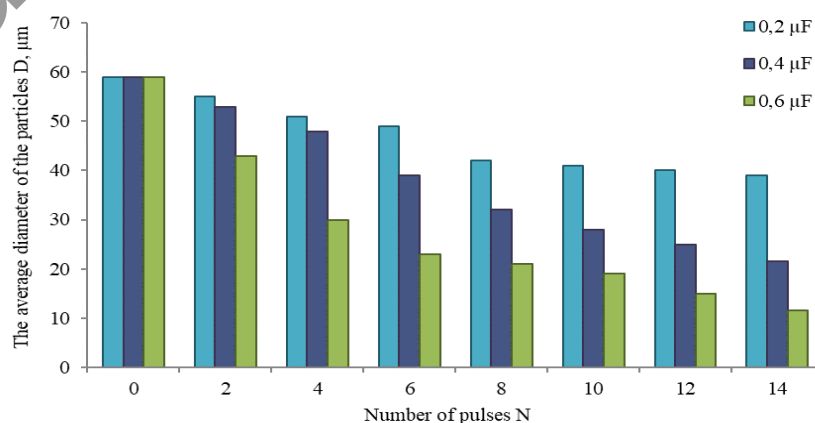

Fig. 8. The average diameter of phosphorus sludge particles distribution at different capacitors.

The figures show that as the number of discharges increases, not only the average diameter decreases, but also the dispersion decreases. This shows that the sludge is becoming more uniform in its dispersed composition. Attention is also drawn to the fact that with an increase in the number of pulses, the average diameter and dispersion change less significantly, the crushing process slows down.

Conclusions

The effect of electro-pulse processing with different parameters is analyzed on the basis of a comparison of the properties and structure after processing. In conclusion, it should be noted, based on the analysis of the above results, the possibility of using high-voltage electrical discharges in the processing of emulsions. By adjusting the parameters and number of processing electric discharge pulses, you can adjust the particle size of the dispersed phase and prepare emulsions with the desired dispersion characteristics. Statistical analysis of the obtained curves shows that particles of a certain size obey the logarithmically normal distribution law. Moreover, during electrohydraulic treatment, some dispersion of phosphorus droplets is first observed, but after settling and coagulation and coalescence processes, the droplet diameter increases, after which the emulsifier separates with released phosphorus. The results of the experiments showed that the use of a pulsed high-voltage discharge makes it possible to extract environmentally friendly products from phosphorus sludge with specified sizes of dispersed particles. This means that the electrochemical processing of phosphorus sludge into high-quality products can improve technical and economic performance and improve environmental performance, in which the environment is less polluted by toxic waste.

REFERENCES

- 1 Cherepanova G.P. Extraction of phosphorus from sludge in a dynamic coagulation apparatus. Abstract dis. ... candidate of chemical sciences. St. Petersburg, 1992, 16 p. [in Russian]
- 2 Saran M.S., Laxbacker D.W. Method for extracting phosphorus from water sludge. Patent RU 2351665. Glenn spring holding, INC. (US). Publ. 03.21.2013, 6 p.
- 3 Mukashev B.N., Beketov B.A., Chokin K.Sh., Tamendarov M.F. *Method for processing phosphorus sludge*. Patent of the Republic of Kazakhstan No. 8628. Published: 03/15/2000, 4 p.
- 4 Tuyakbaev A.A., Tulebaev A.K., Beketov B.A. Method for processing phosphorus sludge. Patent RU 1816735C. Publ. 05/23/1993, 7 p.
- 5 Dormeshkin O.B., et al. Study of the process of hydraulic classification of phosphorus sludge in order to extract phosphorus for the production of glyphosate. *Proceedings of the National Academy of Sciences of the Republic of Kazakhstan. Chemistry and Technology Series*. 2017, No. 6 (426), pp. 97–102.
- 6 Zakolodina T.V. System analysis of phosphorus industry waste disposal based on the CALS concept. Abstract diss. candidate of technical sciences. 2008, 22p.
- 7 Aldashov B.A., Lisitsa V.I. *Utilization of Karatau phosphorite waste - the path to a competitive economy and environmental improvement*. Almaty: Gylym, 2007, 428 p.
- 8 Bekaev A.A., et al. Using the L.A. effect Yutkin in electrohydraulic devices. *Proceedings of the Intern. scientific and technical Conf. dedicated to the 145th anniversary of MSTU, "MAMI"*, 2010, pp. 22 - 32. [in Russian]
- 9 Yutkin effect. Spheres of application of electrohydraulic effect. *ElectroHydroDynamics*. Available at: <https://electro-hydrodynamics.rf/effect-yutkin/> [in Russian]
- 10 Sakipova S.E., Nussupbekov B.R., Ospanova D.A., et al. Effect of electric pulse processing on physical and chemical properties of inorganic materials. *IOP Conf. Series: Materials Science and Engineering*. 2015, Vol. 81, pp. 012051. doi:10.1088/1757-899X/81/1/012051
- 11 Satybalidin A.Zh., et al. The influence of a high-voltage discharge on the oil bottom sediments formed at the oil storage facilities of the Atasu-Alashankou station. *Eurasian phys. tech. j.* 2021, Vol.18, No.3(37), pp. 71 - 75.