

USE OF COLLIMATION REGIME OF CHARGED PARTICLE BEAM FOR EXPAND THE FUNCTIONAL CAPABILITIES OF CORPUSCULAR OPTICAL SYSTEMS

Saulebekov A.O.¹, Kambarova Zh.T.²

¹ Kazakhstan branch of Lomonosov Moscow State University, Nur-Sultan, Kazakhstan

² E.A. Buketov Karaganda University, Karaganda, Kazakhstan, kambarovazht@gmail.com

The approach for the modeling of corpuscular-optical systems for the analysis of charged particle flows is considered. For all the methods considered and used earlier, the condition of spatial focusing of the particle beam was required. However, this strict condition is not always feasible in combination with other requirements. When a cylindrical electrostatic mirror analyzer is used as the main element, spatial focusing of the beam is incompatible with focusing in time of flight in terms of energy. In the paper the possibility of using the collimation regime of charged particle beam is considered, thereby eliminating the need to fulfill the focusing condition.

Keywords: electron spectroscopy, collimation, energy analyzer, corpuscular-optical systems.

Introduction

At present, electron and ion optics have not lost their relevance and continue to develop. The use of electron spectroscopy methods in microelectronics, diagnostics of materials, processing and control of surfaces has a significant impact, while these methods are used in solving technological and scientific problems. For fully solve the problems of studying the surface of a solid body, it is necessary to use a set of mutually complementary methods. Methods such as X-ray photoelectron spectroscopy (XPS) or electron spectroscopy for chemical analysis, slow electron diffraction, Auger electron spectroscopy, secondary mass spectroscopy allow, in combination, to obtain complex information about the chemical, energy state and structure of the surface of a solid [1-7]. The XPS or ESCA method occupies a special place here [8-10].

Previously, the problems and existing directions for modeling energy analyzers of charged particle flows were considered. Since the limits of energy change in electron spectroscopy methods lie in the range from units of keV to eV, electrostatic systems are mainly used as energy analyzers. The choice of electrode configurations is dictated by the ease of fabrication, small dimensions, and evaluation of the expected electron-optical characteristics of the device.

Basically, when modeling and calculating corpuscular-optical systems, two directions were used, arising from the following formula $R = \frac{\Delta L}{D} \Gamma$, where R , ΔL , D , Γ are energy resolution, linear smearing of the image, linear energy dispersion and coefficient of linear longitudinal magnification, respectively. By varying these three parameters, problems were solved to achieve certain purposes. The first direction of research was related to reducing image smearing, that is, improving the quality of focusing a beam of charged particles or increasing the focusing order. For widely used analyzers of the type of cylindrical and spherical electrostatic mirrors (CM and SM), the limits and regions of angular focusing were found. For further development of this direction, it was necessary either to complicate the field-forming electrodes [11-16] or to use additional elements.

The second direction is associated with an increase in the magnitude of the linear energy dispersion [17, 18]. The basic principle in this case was as follows. An element with increased angular energy dispersion was used, which was converted into linear dispersion by subsequent cascades in a cylindrical mirror.

Accounting for the coefficient of linear longitudinal magnification in calculations also makes it possible to improve the quality of beam focusing. When modeling analyzers of charged particle beam, the imposition of additional conditions can significantly expand the functionality of the systems. Additional conditions are imposed for each system individually, based on the specific problems for which the device is created.

In multi-cascade systems used to increase the linear energy dispersion with each cascade, the aberrational smearing of the image also increases. Accordingly, it is not possible to improve the energy resolution of the analyzer.

1 Collimating devices based on cylindrical and spherical electrostatic mirrors

One of the functions of electron-optical elements of practical interest is the collimation of charged particle beams. In corpuscular optics, this problem makes it possible to drastically reduce the intensity loss during the transport of charged particle beams and is technically realized by using electrostatic lenses and mirrors. The collimator makes it possible to obtain parallel trajectories of charged particles, which can be transmitted over long distances and fixed on the detector at any point. According to the perturbation theory approach, the quality of collimation can be described by the order, the value of which is determined by the number of simultaneously vanishing derivatives $\frac{d^n \alpha_1}{d\alpha^n} = 0$. α and α_1 are the angles of inclination of the particle trajectories at the exit from the source and after reflection from the mirror, respectively.

In work [19], the problem of collimating charged particles in SM in the inner reflection regime was considered. The conditions for collimation in this regime are determined. It is shown that a high quality of parallelism of trajectories in the beam is achieved under conditions of second-order collimation.

The collimating properties of the SM were studied by the methods of perturbation theory in [20]. The conditions for collimating charged particle beams in SM with outer reflection of the beam are determined. It is shown that the second-order collimation regime is also achieved. Charged particle beam coming from a source and located on the axis of a spherical mirror becomes parallel under certain conditions after outer reflection from the mirror (Fig.1) [21].

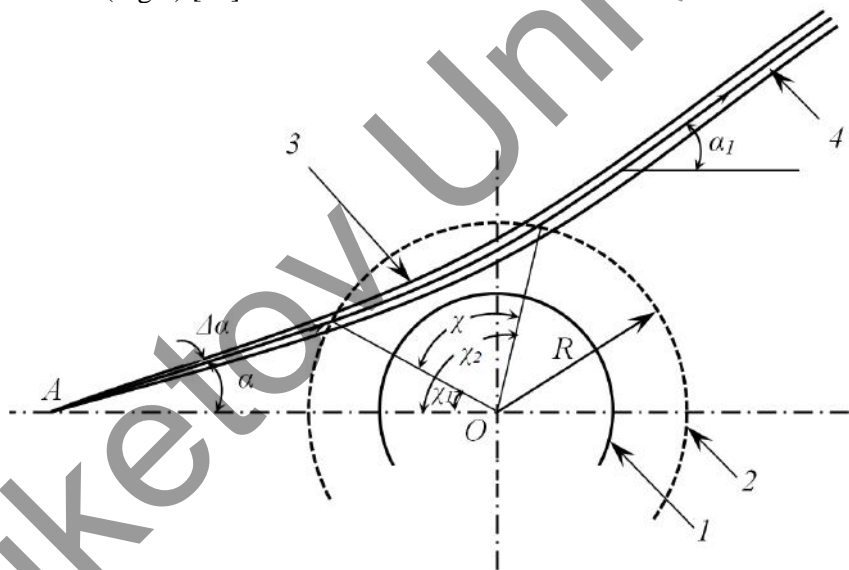

A – point source, 1 – inner spherical electrode, 2 – outer spherical electrode,
3 – trajectories of particles, 4 – parallel beams

Fig.1. The course of trajectories in the spherical mirror at the collimating regime

In Ref. [22], the collimating regime of charged particle beam at a symmetry angle in cylindrical, spherical, and hyperbolic (HM) electrostatic mirrors were calculated. The system of sequentially located CM and SM (Figs. 2 and 3), as well as a system of CM and GM in the regime of collimating charged particles at an angle to the symmetry axis of the system, is considered. It has been determined that the angular energy dispersion of the system of SM and CM significantly exceeds the angular dispersion of a single SM. This makes it possible to use it both independently and as an element with a large angular energy spread with its subsequent transformation into a linear dispersion by means of cylindrical mirrors (Fig. 4). Since, in the future, in this work, the GM is not used, then the regimes and schemes with this mirror are not presented in the work.

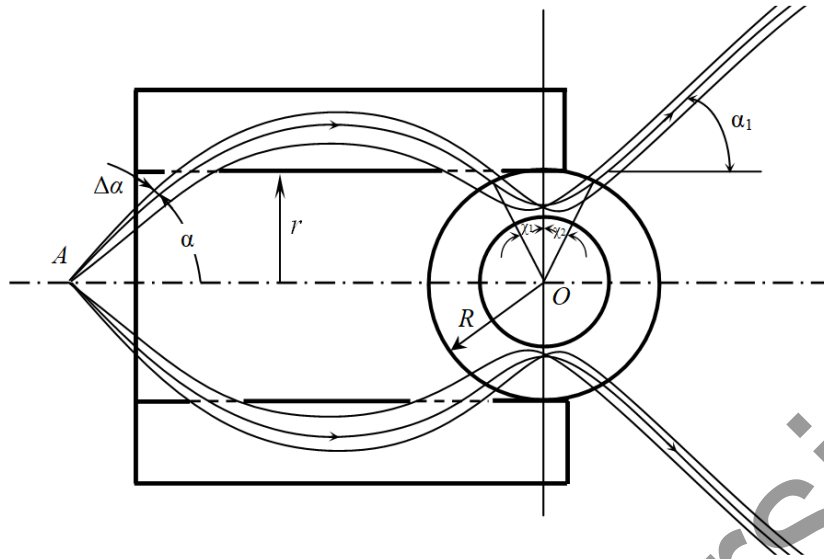

Fig.2. The system of CM and SM in the collimating regime of charged particle beam at an angle to the axis, the angular dispersion in energy is 4.6° per one percent change in the kinetic energy of the particle, the theoretical broadening of the beam at a path length of 1 m after the collimator is 0.6 mm.

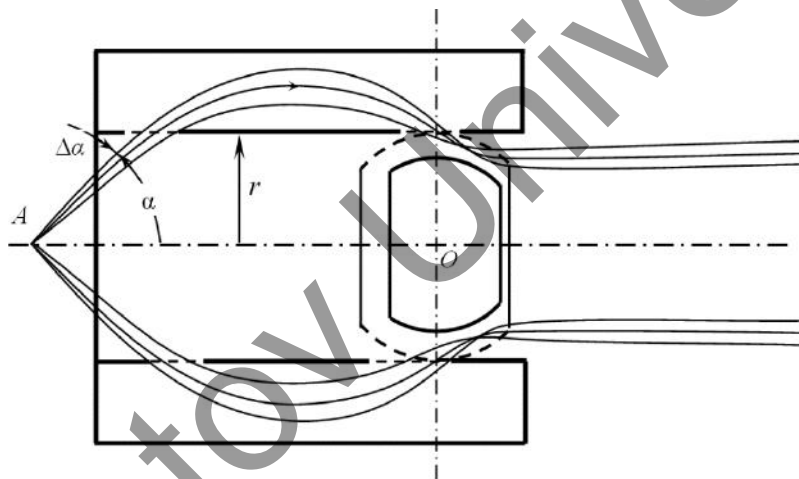

Fig.3. The system of CM and SM in the collimating regime of charged particle beam along the axis, the angular dispersion in energy is 5.4° per one percent of the change in the kinetic energy of the particle

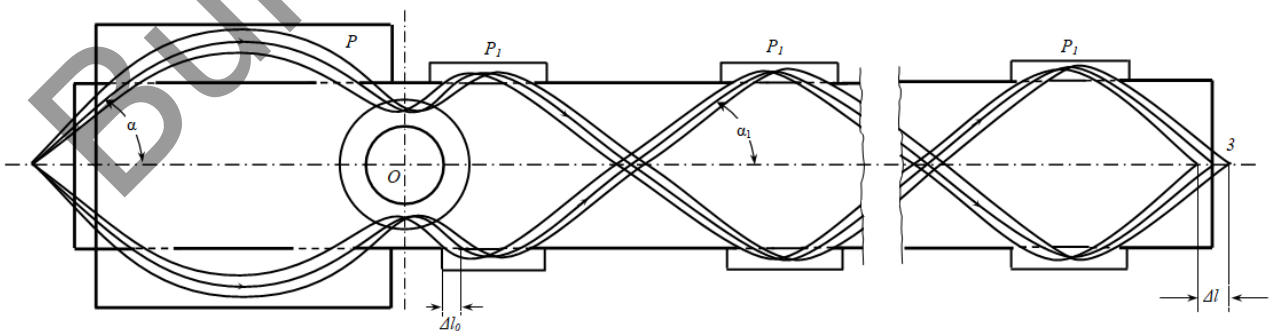

Fig.4. The energy analyzer of charged particle beam with high energy dispersion in the collimated regime, energy resolution 0.038% in the case of one cascade, with two stages 0.024% at luminosity 1.665% of 4π

2 Application of the collimation regime for provide the possibility of carrying out time-of-flight mass analysis in a system of SM and CM

Let's show that the condition of spatial focusing of charged particle beam is incompatible with focusing in time of flight in terms of energy. Let's consider the time-of-flight properties of the trajectories of charged particles in the CM. According to [22], the time of flight T of a charged particle with an initial velocity v , in the section between the points of entrance and exit from the CM field from "n" reflection cascades, is

$$T = 2 \frac{r}{v} \sqrt{1 + \operatorname{ctg}^2 \alpha} n \left[1 - \frac{\delta}{2n} + 2P\theta \right], \quad (1)$$

where δ is radius of ring source, α is angle of inclination of the trajectory to the symmetry axis of the system, W is particle kinetic energy, $p = \sqrt{\frac{W}{qv} \ln \frac{r}{r_0}} \sin \alpha$ is reflection parameter of CM,

$$\theta(p) = e^{p^2} \int_0^{p^2} e^{-x^2} dx, \quad q \text{ is particle charge [23].}$$

Let's demand the independence of time from the energy in the first approximation with respect to ε , where $\varepsilon = \frac{W - W_0}{W_0}$ [24]. It follows from this condition that

$$1 - \frac{\delta}{2n} = 2P^2 (1 + 2P\theta). \quad (2)$$

Since $0 \leq \delta \leq 1$, then all solutions of equation (2) are contained within the boundaries from $P=0.5404$ ($\delta=0$) to $P=0.4222$ ($\delta=1, n=1$). The time-of-flight changes due to the spread in the angle of inclination of the trajectories are determined by the derivatives of T with respect to α . Differentiating (1) twice with respect to α , we obtain [24]

$$\frac{v}{r} \frac{dT}{d\alpha} = 2 \operatorname{ctg} \alpha \sqrt{1 + \operatorname{ctg}^2 \alpha} n \left[-1 + \frac{\delta}{2n} + 2P^2 (1 + 2P\theta) \right], \quad (3)$$

$$\begin{aligned} \frac{v}{r} \frac{d^2T}{d\alpha^2} = & 2 \sqrt{1 + \operatorname{ctg}^2 \alpha} n \left\{ -(1 + 2 \operatorname{ctg}^2 \alpha) \left(1 - \frac{\delta}{2n} + 2P\theta \right) + \right. \\ & \left. + 4P^2 \operatorname{ctg}^2 \alpha \left[(1 + 2P\theta)(1 + P^2) + P\theta \right] \right\} \end{aligned} \quad (4)$$

If condition (2) is satisfied, then, as follows from Eq. (3):

$$dT/d\alpha = 0.$$

Thus, in the CM, in the first approximation in ε and α , temporal focusing is carried out, both in energy and in the angle of inclination of the trajectories.

Let us now turn to angular focusing in terms of the opening angle of beam at the source exit. Let's take the derivative with respect to the angle α of the axial path function [23]

$$L = 2n \operatorname{ctg} \alpha \left[1 - \frac{\delta}{2n} + 2P\theta \right] \quad (5)$$

and equate it to zero, then we obtain the condition for spatial focusing of charged particles beam in the first approximation in the divergence angle [24,25]

$$\operatorname{ctg}^2 \alpha = \frac{1 - \frac{\delta}{2n} + 2P\theta}{2P^2(1 + 2P\theta) - 1 + \frac{\delta}{2n}} \quad (6)$$

When condition (2) is satisfied, when $2P^2(1 + 2P\theta) \rightarrow 1 - \frac{\delta}{2n}$, $\operatorname{ctg}^2 \alpha \rightarrow \infty$ and $\alpha \rightarrow 0$. Consequently, in a CM, the spatial focusing of the beam is incompatible with the time-of-flight- focusing in terms of energy. If the analyzed beam has an initial angular divergence, then the time-of-flight mass-analysis under conditions of temporary energy focusing is accompanied by a longitudinal smearing of the beam, which increases with an increase in the number of cascades “ n ”.

To avoid increasing smearing of the image at the entrance to the CM, narrow beams collimated at an angle to the symmetry axis of the CM should be formed; then, even with multiple reflections from the CM, the longitudinal smearing will be small.

Conclusions

Thus, method is presented that expands the functionality of the CM by implementing the function of time-of-flight mass analysis with a wide transmission range of charged particle energies. This became possible by replacing the condition of spatial focusing of the beam, which is impossible in this case, by the collimation regime. As a collimator placed at the entrance to the CM, the systems shown in Fig. 1 and 2 can be used.

The trajectories of charged particles beam of the same energy W_0 collimated at an angle α to the CM symmetry axis must be identical. The time of flight along these trajectories of charged particles of mass m must be the same. Since the condition of temporal focusing in energy is satisfied in the CM, then for a collimated beam of charged particles of mass m , but of a different energy, in the first approximation in ε , the time of flight remains the same. Due to the linear dispersion in energy D , the collimated energy W beam at the entrance to the slit of the receiving diaphragm will shift along the symmetry axis. This shift is proportional to D and the energy range ε in the particle beam passing through the analyzer. Charged particles of the same mass but different energies arrive at different parts of the receiving slit at the same time. This significantly increases the transmission of the analyzer in the time-of-flight mass analysis regime.

Acknowledgements

The research was supported by the Ministry of Education and Science of the Republic of Kazakhstan, Grant number AP09058188

REFERENCES

- 1 Woodruff D.P., Delchar T.A. *Modern Techniques of Surface Science*. Cambridge University Press; 2nd edition: 1994, 608 p.
- 2 Siladi M. *Electron and ion optics*. Moscow. Mir. 1990, 639 p. [in Russian]
- 3 Weiland C., Rumaiz A.K., Pianetta P. Recent applications of hard x-ray photoelectron spectroscopy. *Journal of Vacuum Science & Technology A*, 2016, Vol.34, Is.3, pp. 030801. doi: 10.1116/1.4946046
- 4 Chen L.X., Zhang X., Shelby M.L. Recent advances on ultrafast X-ray spectroscopy in the chemical sciences. *Chemical science*, 2014, Vol.5, Is.11, pp. 4136-4152. doi: 10.1039/c4sc01333f
- 5 HON, DNS. Fourier-Transform IR Spectroscopy And Electron-Spectroscopy For Chemical-Analysis - Use In The Study Of Paper Documents. *Advances in chemistry series*. 1986, Is. 212, pp. 349-361.
- 6 Baer D.R., Gaspar D.J., Nachimuthu P., et al. Application of surface chemical analysis tools for characterization of nanoparticles. *Analytical and Bioanalytical Chemistry*, 2010, Vol. 396, Is. 3, pp. 983-1002. doi: 10.1007/s00216-009-3360-1
- 7 Barthes-Labrousse, MG. Auger electron spectroscopy and X-ray photoelectron spectroscopy - Principle and applications. *Vide-Science Technique Et Applications*, 2003, Vol.58, Is.308, pp. 353.
- 8 Zigban K., Nordling K., Falman A., et al. *Electron Spectroscopy*. Moscow, Mir, 1971, 493 p. [in Russian]
- 9 Penent F, Lablanquie P, Hall RI. Coincidence Auger spectroscopy. *Journal of Electron Spectroscopy and Related Phenomena*, 2005, Vol. 144, pp. 7-11. doi: 10.1016/j.elspec.2005.01.187

10 Ohno, Masahide. Many-body theory of the Auger Auger-electron coincidence spectroscopy (AAECS) spectra of solids. *Chemical Physics*, 2012, Vol.393, Is.1, pp. 74-79. doi: 10.1016/j.chemphys.2011.11.028

11 Saulebekov A.O., Vénos D., Kambarova Zh.T., et al. Development of energy analyzer of charged particles based on the basis non-uniform electrostatic field. *Eurasian Physical Technical Journal*, 2019, Vol.16, No.1 (31), pp. 24-29.

12 Kambarova Zh.T., Saulebekov A.O. Development of a mirror energy analyzer of charged particles beams based on a modified electrostatic field. «Book Series: 7th International Congress «Energy Fluxes and Radiation Effects» (IEEE Xplore Digital Library).», pp.1028-1030. doi: 10.1109/EFRE47760.2020.9242029

13 Kambarova Zh.T., Saulebekov A.O. Analyzer of charged particles based on the electrostatic quadrupole-cylindrical field in the «axis-ring» focusing regime. «Book Series: 7th International Congress «Energy Fluxes and Radiation Effects» (IEEE Xplore Digital Library), pp.1031-1033. doi: 10.1109/EFRE47760.2020.9242088

14 Kambarova Zh.T., Trubitsyn A.A., Saulebekov A.O. Axially symmetric energy analyzer based on the electrostatic decapole-cylindrical field. *Technical Physics*, 2018, Vol.63, No.11, pp.1667–1671. doi: 10.1134/S1063784218110142

15 Baranova L.A. Charged particle energy analyzer based on a modified cylindrical mirror in the ring-axis focusing mode. *Technical physics*, 2014, Vol. 59. Iss. 3, pp. 463-465. doi:10.1134/s1063784214030049

16 Baranova L.A. Cylindrical mirror energy analyzer with the input of charged particles through end-surface diaphragm. *Technical physics*, 2016, Vol. 61, Iss. 8, pp. 1272-1274.

17 Ashimbaeva B.U., Chokin, K.Sh., Saulebekov A.O., Kambarova Zh.T. The combined energy analyzer composed of electrostatic mirror fields. *Journal of Electron Spectroscopy and Related Phenomena*, 2012, V.185, №11, pp.518-522.

18 Ashimbaeva B.U., Chokin, K.Sh., Saulebekov A.O., Kambarova Zh.T. Modeling of an electrostatic system from cylindrical and hyperbolic mirrors. *Prikladnaya fizika*, 2012, № 4, pp . 73-78. [in Russian].

19 Zashkvara V.V., Yurchak L.S., Bylinkin A.F. Electron-optical properties of electrostatic spherical mirror and systems based on it (I). *Zh. Tekh. Phys.*, 1989, V.58, № 10, pp. 2010-2020. [in Russian].

20 Zashkvara V.V., Saulebekov A.O., Ashimbaeva B.U. Electron-optical properties of electrostatic spherical mirror and systems based on it. II. The electrostatic spherical mirror in external reflection of charged particles beam. *Zh. Tekh. Phys.*, 1989, V.59, № 7, pp.1-9. [in Russian].

21 Saulebekov A.O., Assylbekova S.N., Kambarova Zh.T., Orakbai A. Modeling of electrostatic collimator of charged particles beams on the basis of spherical mirror. *Eurasian phys. tech. j.*, 2016, V.13, No 1 (25), pp. 22-26.

22 Saulebekov A.O., Assylbekova S.N., Tazhibaeva S.D., et al. Collimation of charged particles beam in electrostatic cylindrical, spherical and hyperbolic mirrors. *Bulletin of University of Karaganda*, 2004, №2 (34), pp.50-55.

23 Zashkvara V.V., Ilyin A.M., Ashimbaeva B.U. Time-of-flight mass separator based on electrostatic cylindrical mirrors. *Zh. Tekh. Phys.*, 1980, T.50, №7, pp.1464-1470. [in Russian].

24 Gurov V.S., Saulebekov A.O., Trubitsyn A.A. *Approximate-Analytical and Numerical Methods in the Design of Energy Analyzers/ Advances in imaging and electron physics*. Analytical Editor-in-chief Peter W. Hawkes CEMES-CNRS Toulouse, France. - Academic Press is an imprint of Elsevier, 2015. - Volume 192.- 224p.

25 Ashimbaeva B.U., Chokin K.Sh., et al. Energy analysis and time-flight mass- analysis of spherical and cylindrical mirrors system. *Eurasian phys. tech. j.*, 2007, V.4., No 2(8), pp.45-51.