

A.A.Semenov, G.M.Kozhushko, T.V.Sakhno

*Poltava University Economy and Trade, Ukraine
(E-mail: sakhno2001@mail.ru)*

Device for germicidal disinfection of drinking water by using ultraviolet radiation

The results of the physical implementation of nonchemical methods of bactericidal water disinfection by UV irradiation are presented. The necessary calculations dose inactivation of bacteria, depending on the size of the camera exposure, the power of the radiation source and the irradiation time are carried out. On the basis of theoretical calculations and experimental data the device for bactericidal inactivation of drinking water has been proposed.

Key words: UV-method, ultraviolet disinfection of drinking water, a dose of bactericidal disinfection, ultraviolet irradiation.

Introduction

The method of ultraviolet disinfection of water is one of the physical, reagentless methods [1]. These methods have a number of significant advantages over chemical reagent method [2–4], most of which is the lack of changes in the composition and organoleptic properties (smell, taste). In cases of overdose the chemical reagent method also may have some negative effects. Ultraviolet radiation allows destroy viruses and fungi which do not apply the traditional chemical methods, including chlorination [5].

Bactericidal effect of ultraviolet radiation acts on the wavelength range of 205–315 nm which leads to photochemical damage of DNA [6]. Changes in the DNA of microorganisms accumulate and lead to a slow-down in their breeding and subsequent extinction in the first and subsequent generations [7]. The most effective impact energy of UV radiation from germicidal perspective occurs at a wavelength of 253.7 nm [8].

Materials and methods

The main purpose of using new methods and technical approaches is to improve the bactericidal disinfection of drinking water. However, achieving this goal is accompanied, as a rule, by complexity of construction and increasing operating costs.

There are several examples of the well-known devices of similar function. For instance, [8] described a device decontamination of aqueous media by treatment with ultraviolet radiation generated by the UV lamp. The source of UV radiation is a vacuum ultraviolet lamp barrier discharge filled with xenon, which emits monochromatic beam with a wavelength of 172 nm placed inside the reactor containing the inner and outer electrodes which are connected to the power source. The described device can be used to purify water from organic compounds. Disadvantages of this method include the following: when the vacuum ultraviolet barrier discharge lamp that emits monochromatic beam with a wavelength of 172 nm is used in the installation for disinfecting, the bactericidal effect is very small, because the action spectra have a pronounced maximum at wavelengths between 260 ÷ 283 nanometers [9].

In [10] the effectiveness of bactericidal disinfection of water is achieved by simultaneous exposure to ozone and ultrasonic waves. The use of ozone [7], however, leads to complication of the design and installation of additional costs for its maintenance. In addition, the design of the installation cannot create a significant overpressure, which significantly limits its performance.

The purpose of the proposed technical solution is to simplify the design and reduce maintenance costs while maintaining the efficiency of disinfection of water.

Results and discussion

In the known structures devices of productivity and the size of the Rays camera calculated by standard methods [11, 12] using the experimentally determined volumetric dose to inactivate various types of microorganisms H_V . The disadvantage of this approach is that the volume dose H_V depends on the geometry of the camera for exposure and degree of mixing water during irradiation in laminar flow. The layers of water that are closer to the UV lamp — the radiator will get «excessive» dose, and the layers of water are near the chamber walls — not receive required dose (if there is a sufficient the average value H_V). To obtain the required dose of disinfection H_S , the size of the camera for radiation (diameter and length) should provide the

required minimum radiation E_{\min} . Other areas will receive «excessive» exposure that only increases the reliability of disinfection.

The required dose H_s ($W \cdot cm^2$) is achieved variation E_{\min} ($W \cdot m^2$) or time t (s):

$$H_s = E_{\min} \cdot t.$$

Effective time t (s) for residence of water in the installation is determined by the formula

$$t = \frac{V_a}{3600 \cdot Q} = \frac{V - V_1}{3600 \cdot Q},$$

V — cavity, capacity irradiated, m^3 ; V_1 — the volume of the submerged part of the outer bulb of lamps, m^3 ; Q — performance installation $m^3 \cdot h^{-1}$.

For installation in which the lamp is immersed in water and its length (see Fig.) is comparable to the length of cavity that irradiated minimum irradiation E_{\min} (irradiation on a cylindrical surface of radius R^2) can be determined from the expression:

$$E_{\min} = \frac{E_1 \cdot R_1}{R_2 \cdot e^{-k(R_1 - R_2)}},$$

E_1 — Irradiation on the surface of the radius R_1 (on the outer surface of the bulb lamp); R_2 — inner diameter cavity that irradiated; k — attenuation of radiation passing through the water.

Time for acquiring the required dose H_s is:

$$t_{\min} = \frac{H_s \cdot R_2 \cdot e^{-k(R_1 - R_2)}}{E_1 R_1}.$$

The minimum rate of water movement in cavity that irradiated is:

$$g_{\min} = \frac{l \cdot E_1 \cdot R_1}{H_s \cdot R_2 \cdot e^{-k(R_1 - R_2)}},$$

l — arc discharge of germicidal lamps.

Plant capacity for disinfection process is determined from the equation

$$V = \frac{E_2 \cdot l \cdot \pi \cdot R_1 \cdot e^{-k(R_1 - R_2)}}{H_s R_2} (R_2^2 - R_1^2).$$

Under these conditions, even in the case of laminar flow (when layers of water do not mix), layers of water that are far from the ultraviolet lamp, will receive the required dose for inactivation [13].

The proposed installation for bactericidal disinfection of drinking water (Fig.) is equipped with mercury arc lamp which serves as irradiator. The lamp is a source of ultraviolet radiation, which has a detrimental effect on bacteria, viruses and other microorganisms [14, 15].

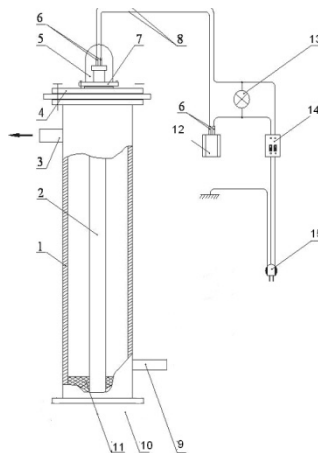

Figure. The experimental setup for bactericidal disinfection of drinking water: 1 — the camera; 2 — lamp; 3 — upper pipe; 4 — the top flange of the lamp; 5 — cap; 6 — blocks; 7 — flange with seal ring; 8 — wire; 9 — lower pipe; 10 — solid bottom flange; 11 — buffer stop; 12 — electromagnetic ballast; 13 — the indicator light; 14 — circuit breaker; 15 — plug with connecting wire and grounding wire

The installation consists of a cylindrical chamber 1, which has a germicidal lamp 2 placed in the cavity. Water in the chamber is supplied through inlet 9, which is located at the bottom of the camera, and removal sanitized water occurs through pipe 3. Lamp 2 is connected via 15 of the connecting plug wire and grounding wire through the circuit breaker 14, an electromagnetic ballast 12, wires 8 and pads 6. Circuit breaker, electromagnetic ballast and LED lamp 13 are covered with plastic boxes attached to the frame. To control the voltage on the lamp, there is an indicator LED [16].

Water disinfection is carried out during its flow through the chamber due to UV exposure. The control panel consists of a motor-starting devices for lights and alarms when deviations from the desired mode. Disinfection can be accomplished within 2 minutes after starting the process (the time required for primary disinfection of the water in the chamber exposure).

Conclusions

The principle of operation of the device for germicidal disinfection of drinking water based on the following — E_{\min} is calculated from the condition: $H_s \geq 100 \frac{m \cdot J}{cm^2}$.

As can be seen from the description of the installation, its design is safer, significantly more simple, and requires no additional costs for maintenance, compared to known devices.

Based on the proposed technical solution the series of installations for bactericidal disinfection of drinking water have been developed and successfully used by a number of companies in Ukraine. The ability to pass water through the installations depends on the pressure of the water and can vary from 1,000 to 5,000 liters per hour. Actual performance of disinfection process depends on the concentration and type of harmful microorganisms, the desired degree of disinfection and water transparency, and can be determined empirically by the results of microbiological analysis of water.

References

- 1 Gray N.F. Ultraviolet Disinfection. In: S.L. Percival, M.V. Yates, D. Williams, R. Chalmers, N. Gray Editor (Eds.), *Title of book: Microbiology of Waterborne Diseases: Microbiological Aspects and Risks (Second Edition)*. Chapter Thirty-Four. — 2014. — P. 617–630.
- 2 Jeong J., Kim C., Yoon J. The effect of electrode material on the generation of oxidants and microbial inactivation in the electrochemical disinfection processes // *Water Research*. — 2009. — Vol. 43 (4). — P. 895–901.
- 3 Lin S., Huang R., Cheng Y., Liu J., Lau B.L.T., Wiesner M.R. Silver nanoparticle-alginate composite beads for point-of-use drinking water disinfection // *Water Research*. — 2013. — Vol. 47 (12). — P. 3959–3965.
- 4 Huang J., Wang L., Ren N., Ma F., Juli. Disinfection effect of chlorine dioxide on bacteria in water // *Water Research*. — 1997. — Vol. 31 (3). — P. 607–613.
- 5 Liu W., Zhang Z., Yang X., Xu Y., Liang Y. Effects of UV irradiation and UV/chlorine co-exposure on natural organic matter in water // *Science of The Total Environment*. — 2012. — Vol. 414. — P. 576–584.
- 6 Shaban A.M., El-Taweel G.E., Ali G.H. UV ability to inactivate microorganisms combined with factors affecting radiation // *Water Science and Technology*. — 1997. — Vol. 35 (11–12). — P. 107–112.
- 7 Presnell M.W., Cummins J.M. Effectiveness of ultra-violet radiation units in the bactericidal treatment of seawater // *Water Research*. — 1972. — Vol. 6 (10). — P. 1203–1212.
- 8 Naunovic Z., Lim S., Blatchlev III E.R. Investigation of microbial inactivation efficiency of a UV disinfection system employing an excimer lamp // *Water Research*. — 2008. — Vol. 42 (19). — P. 4838–4846.
- 9 Christofi N., Misakyan M.A., Matafonova G.G., Barkhudarov E.M., Batoev V.B., Kossyi I.A., Sharp J. UV treatment of microorganisms on artificially-contaminated surfaces using excimer and microwave UV lamps // *Chemosphere*. — 2008. — Vol. 73 (5). — P. 717–722.
- 10 Dahl E. Physicochemical aspects of disinfection of water by means of ultrasound and ozone // *Water Research*. — 1976. — Vol. 10 (8). — P. 677–684.
- 11 Wasserman A.L., Shandala M.G., Yuzbashev V.G. Ultra-violet radiation in prophylaxis infectious diseases. — M.: Medicine, 2003. — 208 p.: silt. ISBN 5-225-04324-0.
- 12 Elyasi S., Taghipour F. Simulation of UV photoreactor for water disinfection in Eulerian framework // *Chemical Engineering Science*. — 2006. — Vol. 61 (14). — P. 4741–4749.
- 13 Silva A.B., Filho N.M.L., Palha M.A.P.F., Sarmiento S.M. Kinetics of water disinfection using UV-C radiation // *Fuel*. — 2013. — Vol. 110. — P. 114–123.
- 14 Vidar L., Hongve D. Ultraviolet irradiated water containing humic substances inhibits bacterial metabolism // *Water Research*. — 1994. — Vol. 28 (5). — P. 1111–1116.
- 15 Semenov A.A., Kozhushko G.M. Bactericidal irradiators for ultraviolet disinfection of indoor air // *European Applied Sciences*. — 2013. — Vol. 1 (13). — P. 226–228.
- 16 Kozhushko G.M., Semenov A.A., Berlinova L.V. Installation bactericidal disinfection of drinking water, Ukraine Patent № 71953, the IPC S02F 1/32 (2006.01). from 21/03/2012.

А.А.Семенов, Г.М.Кожушко, Т.В.Сахно

Ультракүлгін сәуле көмегімен ауыз суды бактерицидті залалсыздандыру құрылғысы

Мақалада ультракүлгін сәуле көмегімен ауыз суды бактерицидті залалсыздандыруды жүзеге асырылғандығы туралы деректер берілген. Бактериялардың уақытша тежелуінің сәуленің қуатына, әсер ету ұзақтығына және сәуле әсер ететін ортаның көлеміне тәуелділігі есептелген. Теория және тәжірибе жүзінде жүргізілген зерттеулердің деректеріне сүйеніп, ауыз суды бактерицидті тазартуға мүмкіндік беретін құрылғы ұсынылған.

А.А.Семенов, Г.М.Кожушко, Т.В.Сахно

Устройство бактерицидного обеззараживания питьевой воды ультрафиолетовым излучением

В работе представлены результаты внедрения физического безреагентного метода бактерицидного обеззараживания воды ультрафиолетовым облучением. Проведены необходимые расчеты дозы инактивации бактерий в зависимости от размеров камеры облучения, мощности источника излучения и времени облучения. На основе проведенных теоретических и экспериментальных расчетов предложено устройство бактерицидного обеззараживания питьевой воды.