

V. A. Bogomolov¹, V. I. Klimenko¹, D. N. Leontiev¹, S. V. Ponikarovska¹,
A.A. Kashkanov^{2*}, V.Yu. Kucheruk²

¹*Kharkiv National Automobile and Highway University, Ukraine;*

²*Vinnitsia National Technical University, Ukraine*

(*E-mail: a.kashkanov@gmail.com)

Plotting the adhesion utilization curves for multi-axle vehicles

The paper presents a method for calculating normal reactions of the road bearing surface along the axles of a multi-axle wheeled vehicle, upon which it is possible to construct the adhesion utilization curves for all vehicle axles, considering that both independent axles and axles combined in balancing trolleys are present in the vehicle suspension. The main idea of this method is developing a universal mathematical model for determining the horizontal coordinate of the center of elasticity (center of rotation) of a multi-axle vehicle body with reference to which the normal reactions along the axles of the vehicle during its braking are determined. In addition, with a known distribution of braking forces, the adhesion utilization curves are plotted. In the overview part, an analysis is given that showed that there is no single methodology or recommendations today regarding determination of normal road reactions on the axles of a multi-axle wheeled vehicle. The developed methodology can be applied in engineering calculations when checking multi-axle wheeled vehicles for compliance with international requirements for brake systems (Appendix 10 to UN / ECE Regulation No. 13). The universality of the proposed methodology allows recommendation for its implementation in the given Rules No. 13. The calculations of the adhesion utilization curves made on the example of a 4-axle vehicle showed that consideration of the design features of a multi-axle wheeled vehicle suspension significantly affects the nature of the geometry of the adhesion utilization curves within the permissible limits specified by UN / ECE Regulation No. 13 (Appendix 10).

Keywords: multi-axle vehicle, distribution of braking forces, braking force, braking performance, adhesion utilization curves, off-road vehicle, multi-axle.

Introduction

From the theory of car, we know that during the designing process and serial tuning all wheeled vehicles (WV) must be provided with the necessary braking performance in various conditions of their operation. To control the assessment of this performance, the standards and regulations have been developed in international practice [1, 2]. They provide for checking the geometry of the adhesion utilization curves of the WV axles [3–10] in predetermined so-called «corridors», that ensure road safety due to the rational choice of the brake system characteristics and implementation of the proper process of vehicle braking [11–17].

In regulatory documents [1, 2] evaluating the braking performance of a WV, the adhesion utilization curve of the i -th axle (f_i) of the wheeled vehicle can be determined based on the equation:

$$f_i = \frac{T_i}{N_i}, \quad (1)$$

where T_i is the braking force on the corresponding i -th axle of a WV, N; N_i is the road reaction to the i -th axle of the WV, N.

The exact solution for (1) in the regulatory documents [1, 2] is proposed only for two-axle vehicles:

$$f_i = \frac{T_i}{P_i \pm z \frac{h}{L} G}, \quad (2)$$

where P_i is the normal road reaction to the corresponding i -th axle of the WV in static conditions, N; h is the height of the WV center of gravity, m; L is the distance between the axles of the WV, m; z is the braking coefficient of the WV; G is the WV weight, N.

An expression similar to formula (2) can also be obtained for a three-axle WV in which the rear two axles are combined by the suspension in one so-called «balancing trolley» [18–20].

For multi-axle WVs [21], with three or more independent axles, it is necessary to develop original methods for each individual case of layout of their axles when determining the reaction of the road.

This approach is not always convenient when plotting adhesion utilization curves and determining the braking performance of a vehicle, consequently the aim of this work is creating a methodology for calculating the reaction of road on the i -th axle of a multi-axle WV when constructing its adhesion utilization curves.

The object of this study is the process of determining the reaction of road on the i -th axle of a multi-axle WV. The relevance lies in the rational determination of the nature of the distribution of the adhesion utilization curves of the multi-axle vehicles in order to ensure road safety and increase the braking efficiency of such vehicles.

Methodology for determining the road reaction on the i -th axle of a multi-axle WV

Work [22] offers to determine the reactions of road N_i in the following form:

$$N_i = P_i + \Delta N_i, \tag{3}$$

where ΔN_i is a dynamic component of the normal reaction of the road to the corresponding i -th axle of the WV, caused by the appearance of the total braking force, which is equal to the inertia of the car, N ;

The main advantage of this representation of quantity N_i is the possibility of applying the so-called principle of superposition of forces acting on the WV. Therewith, value P_i in equation (3) is a reference and depends on the distribution of the car weight relative to its center of gravity. Thus, when determining ΔN_i , the mathematical and physical model of the WV is greatly simplified due to the lack of P_i and G quantities.

Structurally, such a physical model of a multi-axle vehicle can be represented in the form of a circuit depicted in Fig. 1.

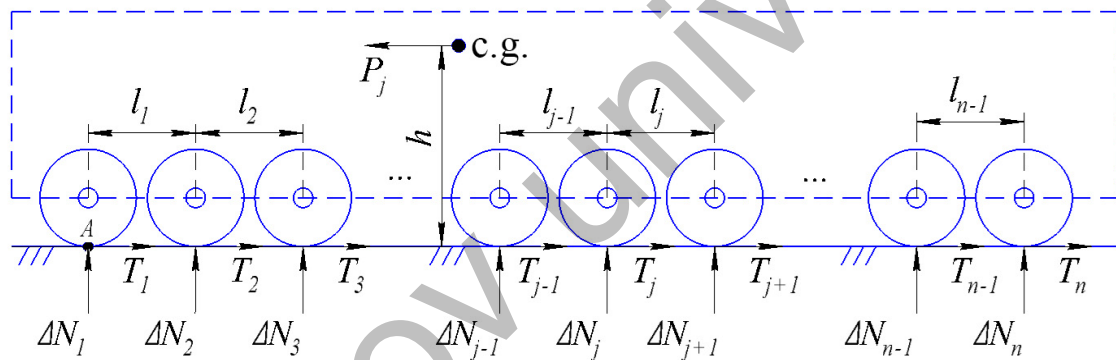

($T_1, T_2, T_3, T_{j-1}, T_j, T_{j+1}, T_{n-1}, T_n$ are braking forces on the corresponding axles of the n -axle WV;
 $l_1, l_2, l_{j-1}, l_j, l_{n-1}$ are the distances between the corresponding axles of the n -axle WV; h is the height of the center of gravity (c.g.) of the WV; P_j is the inertia force of the braking n -axle WV).

Figure 1. Diagram of the structural physical model of the n -axle braking WV

Based on the studies [18], it is obviously possible to accept:

$$P_j = j \cdot \frac{G}{g} = z \cdot G = \sum_{i=1}^n T_i. \tag{4}$$

It is well known from mathematics and theoretical mechanics that in order to find n of unknown quantities (3), it is necessary to obtain a system of n equations.

Since the weight of a WV does not change during braking, we can write the first equation in the following form:

$$\sum_{i=1}^n \Delta N_i = 0. \tag{5}$$

From the sum of the moments relative to point A (Fig. 1), we obtain the second equation in the form:

$$\sum_{k=2}^n \left(\Delta N_k \cdot \sum_{m=1}^{k-1} l_m \right) = -z \cdot G \cdot h. \tag{6}$$

From the scientific and technical literature [2, 18] we know that if, for example, some two axles j and $j + 1$ are combined into a balancing trolley, then we can assume the equality for them:

$$\Delta N_j - \Delta N_{j+1} = 0. \quad (7)$$

Equation (7) may also have a different form, depending on the design of the balancer suspension. There are as many such equations in the system as there are balancing trolleys in the design of the WV.

The practice of calculations [2, 18] shows that under the accepted assumption (7) the axles combined into the balancing trolley can often be conditionally replaced by a reduced axle with loads:

$$\begin{aligned} N_{j,(j+1)} &= N_j + N_{j+1}; \\ P_{j,(j+1)} &= P_j + P_{j+1}; \\ \Delta N_{j,(j+1)} &= \Delta N_j + \Delta N_{j+1}; \\ T_{j,(j+1)} &= T_j + T_{j+1}, \end{aligned} \quad (8)$$

which is located at distance $0,5 \cdot l_j$ from the corresponding axle (Fig. 1).

In this case, the displacement (rotation) of the WV body during braking can be schematically represented in the form of a diagram, which is shown in Fig. 2.

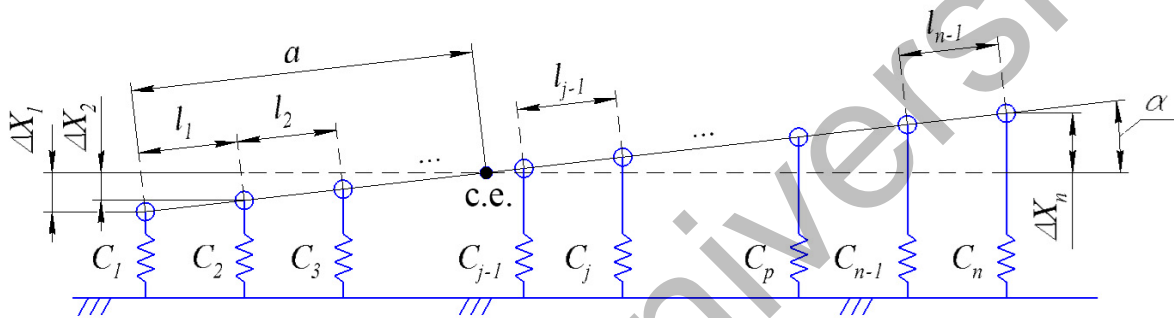

a is the distance from the center of elasticity (c.e.) to the first axle; $C_1 \dots C_n$ are stiffness of the suspensions of the corresponding WV axles; $\Delta X_1 \dots \Delta X_n$ are deformation of the suspensions of the corresponding axles; α is the angle of the body inclination relative to its initial position before the WV starts braking

Figure 2. Diagram of the rotation of the WV body during braking

From the diagram in Fig. 2 it is obvious that expression (5) can be rewritten in the form

$$\sum_{i=1}^n (\Delta X_i \cdot C_i) = 0. \quad (9)$$

From Fig. 2 it is also obvious that:

$$\Delta X_i = \left(a - \sum_{k=1}^i l_{k-1} \right) \cdot \sin \alpha, \quad (10)$$

where if $i = 1$, the distance is $l_0 = 0$.

After substituting expression (10) in (9) and performing simple algebraic transformations, we obtain:

$$a \cdot \sum_{i=1}^n C_i = \sum_{i=1}^n \left(C_i \cdot \sum_{k=1}^i l_{k-1} \right). \quad (11)$$

Dividing the numerator and denominator of expression (11) by the stiffness of the front axle suspension and considering that at $i = 1$ the distance is $l_0 = 0$, we obtain:

$$a = \frac{\sum_{i=2}^n \left(\frac{C_i}{C_1} \cdot \sum_{k=1}^i l_{k-1} \right)}{1 + \sum_{i=2}^n \frac{C_i}{C_1}}. \quad (12)$$

Assuming that during the transition of a vehicle from a running order to a loaded state its body moves parallel to itself [23], we can assume that there is an equality:

$$\Delta X_i^n = const, \quad (13)$$

where ΔX_i^n is deformation in the i -th suspension when moving the body from the running order to the loaded state of the WV.

In that case, it is fair to accept:

$$\frac{C_i}{\Delta P_i} = const, \quad (14)$$

where ΔP_i is the difference between the loads on the i -th axle in the loaded state and running order of the WV.

Thus, we can assume that:

$$\frac{C_i}{C_1} = \frac{\Delta P_i}{\Delta P_1}, \quad (15)$$

after substituting expression (15) into (12), we finally obtain:

$$a = \frac{\sum_{i=2}^n \left(\frac{\Delta P_i}{\Delta P_1} \cdot \sum_{k=1}^i l_{k-1} \right)}{1 + \sum_{i=2}^n \frac{\Delta P_i}{\Delta P_1}}. \quad (16)$$

In equation (16), all components are the well-known reference data [24], which fact subsequently simplifies the calculation of the distance from the center of elasticity to the first axle by dependence (16).

In this regard, the missing equations for the target system of equations can be determined by the following procedure:

– after finding the distance from the center of elasticity to the first axle by dependence (16), we determine the position of the center of elasticity relative to the axles of the WV with index j and n . Moreover, from Fig. 1 and Fig. 2 we know that if:

$$a = \sum_{i=1}^{j-1} l_i, \text{ then for it } \Delta N_j = 0; \quad (17)$$

– for the axles to the left of the center of elasticity, from geometric relations and equation (10) for any m -th axle the following relation is right:

$$a \cdot \Delta X_m = \left(a - \sum_{i=1}^{m-1} l_i \right) \cdot \Delta X_1, \text{ где } m > 1. \quad (18)$$

Considering expressions (5) and (9), after the corresponding transformations for the m -th axle, we obtain the equation:

$$\left(1 - \frac{\sum_{i=1}^{m-1} l_i}{a} \right) \cdot \frac{\Delta P_m}{\Delta P_1} \cdot \Delta N_1 - \Delta N_m = 0; \quad (19)$$

– for the axles located to the right of the center of elasticity, from geometric relationships for any p -th axle the following is valid:

$$\Delta X_p \left(\sum_{i=1}^{n-1} l_i - a \right) = \Delta X_n \left(\sum_{i=1}^{p-1} l_i - a \right). \quad (20)$$

After the transformations, which are similar to the transformations made earlier for expression (18), we obtain the equation:

$$\Delta N_p - \frac{\Delta P_p}{\Delta P_n} \cdot \left(\frac{\sum_{i=1}^{p-1} l_i - a}{\sum_{i=1}^{n-1} l_i - a} \right) \cdot \Delta N_n = 0. \quad (21)$$

Thus, from expressions (19), (21) we can obtain their missing number for the target system of equations.

Plotting the adhesion utilization curves for multi-axle WV

After solving the statically indeterminable system by the method described above and determining the increments of vertical loads on each WV axle during its braking, we find all values of vertical loads N_i from expression (3), and using expression (1) we plot the adhesion utilization curves.

As an example, we address the plotting of adhesion utilization curves for a four-axle truck, schematically shown in Fig. 3, with the parameters [22]:

- the distances between the axles are $l_1 = 2,03$ m, $l_2 = 2,62$ m, $l_3 = 1,4$ m;
- two rear axles are combined by a balancing trolley;
- axle loads in running order $P_{n1} = 25000$ N, $P_{n2} = 25000$ N, $P_{n3} = 49000$ N, $P_{n4} = 49000$ N (axle loads in loaded state $P_{g1} = 73500$ N, $P_{g2} = 73500$ N, $P_{g3} = 131320$ N, $P_{g4} = 131320$ N);
- position of the coordinate of the center of gravity from the road surface when WV is in loaded state $h_n = 1,05$ m (position of the center of gravity coordinate from the road surface when WV is in loaded state $h_g = 1,55$ m);

Thus: $\Delta P_1 = P_{g1} - P_{n1} = 23500$ N, $\Delta P_2 = P_{g2} - P_{n2} = 23500$ N, $\Delta P_3 = \Delta P_4 = 51320$ N.

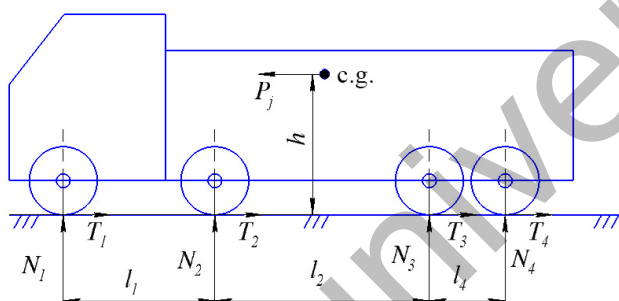

Figure 3. The scheme of the forces acting on the four-axle truck when braking

We assume that the braking forces are realized the same on all axles, i. e.: $T_1 = T_2 = T_3 = T_4 = 0,25 \cdot \sum_{i=1}^4 T_i$. In this case, the system of equations, for example, for the WV in running order, will have the following form:

$$\begin{cases} \sum_{i=1}^4 \Delta N_i = 0; \\ \sum_{j=2}^4 \left(\Delta N_j \cdot \sum_{i=1}^{j-1} l_i \right) = -z \cdot h_n \cdot \sum_{i=1}^4 P_{ni}; \\ \Delta N_3 - \Delta N_4 = 0; \\ \left(1 - \frac{l_1}{a} \right) \cdot \frac{\Delta P_{n2}}{\Delta P_{n1}} \cdot \Delta N_1 - \Delta N_2 = 0. \end{cases} \quad (22)$$

The results of calculations of the utilized adhesion made on the basis of the system of equations (22) using equations (1) and (3) are presented in Fig. 4 (a).

If we consider the same multi-axle vehicle, but without a balancing trolley, then the system of equations (22) will take the form (23). The results of calculations of the utilized adhesion performed according to the system of equations (23) using equations (1) and (3) are presented in Fig. 4 (b).

A comparative analysis of the results of calculations performed according to the systems of equations (22) and (23) shows their significant discrepancy. This allows us to conclude that neglecting the type of suspension when calculating the adhesion of a multi-axle vehicle is unacceptable, since this leads to significant errors in calculating distribution of braking forces between the axles of such WVs.

The calculations of the utilized adhesion for a loaded vehicle according to equations (22) and (23) using equations (1) and (3) also showed a significant discrepancy between the results. For convenience of analysis, the results of calculations of a loaded WV utilized adhesion are depicted in the form of graphs in Fig. 5.

$$\begin{cases} \sum_{i=1}^4 \Delta N_i = 0; \\ \sum_{j=2}^4 \left(\Delta N_j \cdot \sum_{i=1}^{j-1} l_i \right) = -z \cdot h_n \cdot \sum_{i=1}^4 P_{ni}; \\ \Delta N_3 - \frac{\Delta P_{n3}}{\Delta P_{n4}} \cdot \left(\frac{\sum_{i=1}^2 l_i - a}{\sum_{i=1}^3 l_i - a} \right) \cdot \Delta N_4 = 0; \\ \left(1 - \frac{l_1}{a} \right) \cdot \frac{\Delta P_{n2}}{\Delta P_{n1}} \cdot \Delta N_1 - \Delta N_2 = 0. \end{cases} \quad (23)$$

As the analysis of the curves of the utilized adhesion of an n -axle WV showed, its distribution of braking forces depends significantly on the chosen calculation method.

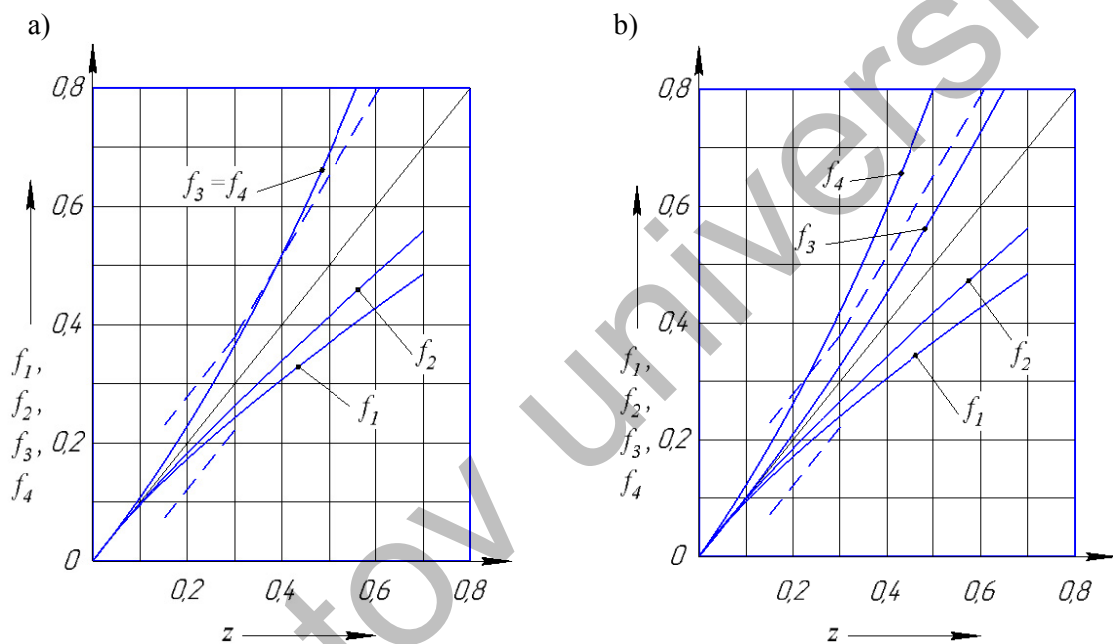

a) two rear axles are combined into a balancing trolley; b) two rear axles are not combined into a balancing trolley

Figure 4. The curves of the utilized adhesion of a four-axle WV in running order

The design of the axle suspensions of the n -axle WVs also affects the nature of the change in its utilized adhesion; therefore, the methodology for calculating the curves of the utilized adhesion of a multi-axle WVs must consider this when fulfilling the requirements of the UN / ECE Rules [1].

The analysis of the deviation in the average value of the utilized adhesion on the front axes for a four-axle vehicle with a balancing trolley and with independent axles is determined from the expression:

$$\Delta = \frac{\max(f_a^u; f_{cp}^b) - \min(f_a^u; f_a^b)}{\max(f_a^u; f_a^b)} \cdot 100\%, \quad (24)$$

where f_a^u is an average adhesion utilized on the front or rear axles of a multi-axle wheeled vehicle with independent axles; f_a^b is the average value of the adhesion utilized on the front or rear axles of a multi-axle wheeled vehicle with a balancing trolley in its design.

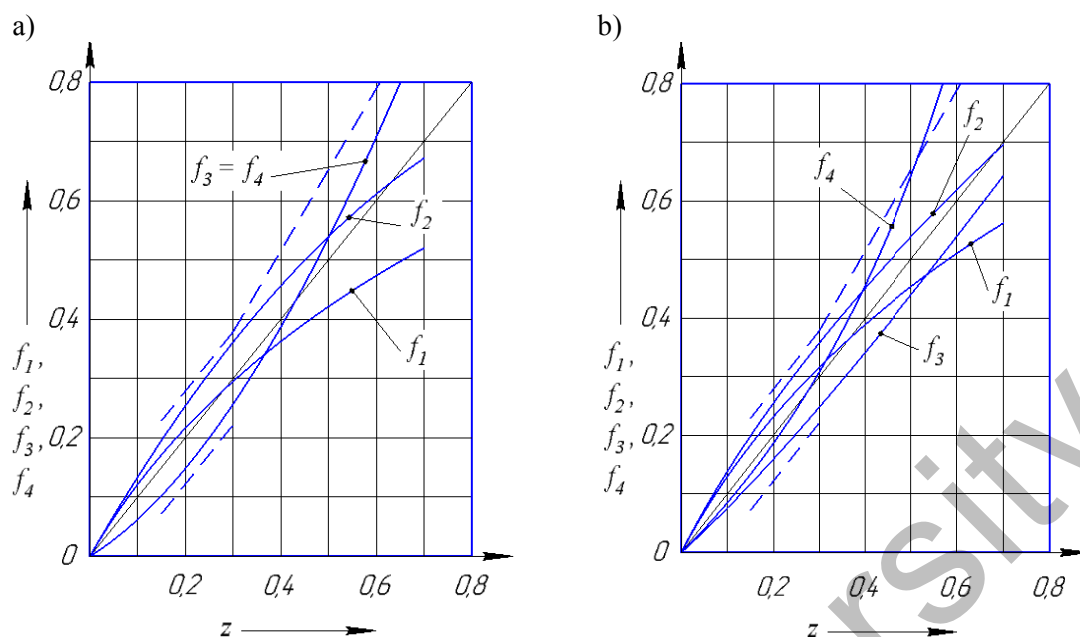

a) two rear axles are combined into a balancing trolley; b) two rear axles are not combined into a balancing trolley

Figure 5. The curves of the utilized adhesion of a loaded four-axle WV

The results of the calculated deviation in the average value of the utilized adhesion on the front axles and rear axles of a four-axle WV, when z equals 0.5, are summarized for convenience in Table 1.

Table 1

The average deviation of the utilized adhesion of a four-axle WV

Parameter	f_a^b	f_a^u	$\Delta, \%$	f_a^b	f_a^u	$\Delta, \%$
Mode	WV in running order			WV in loaded state		
Front	0,39	0,395	1,27	0,48	0,495	3,03
Rear	0,7	0,69	1,43	0,53	0,54	1,85

The table shows that, with an average deviation in the calculation results not exceeding 1.5 %, the curves of utilized adhesion shown in Fig. 4 significantly differ from each other by the nature of their geometry within the established limits [1].

A similar trend is also observed for a loaded multi-axle wheeled vehicle (Fig. 5). Moreover, the percentage deviation of the average utilized adhesion is almost doubled in comparison with the average value of the utilized adhesion of the WV in running order.

Table 2

Deviation of the WV utilized adhesion from its average value

Parameter	f_a^b	f_a^u	$\Delta_b, \%$	$\Delta_u, \%$	f_a^b	f_a^u	$\Delta_b, \%$	$\Delta_u, \%$
Mode	WV in running order				WV in loaded state			
f_1	0,36	0,37	7,69	6,33	0,42	0,45	12,5	9,09
f_2	0,42	0,42	7,14	5,95	0,54	0,54	11,11	8,33
f_3	0,7	0,58	0	15,94	0,53	0,43	0	20,37
f_4		0,8		13,75		0,64		15,63

The deviation of the utilized adhesion from its average value (Table 2) showed that in calculation of the utilized adhesion for the WV with a balancing trolley in suspension the error Δ_b will be bigger when calculat-

ing the utilized adhesion of the front axles; and without such a trolley in the suspension the deviation Δ_u will be bigger when calculating the utilized rear axle adhesion.

It should be noted that the error in determining the utilized adhesion above 15 % is not permissible for engineering calculations, since under actual operating conditions of a multi-axle wheeled vehicle this can lead to a violation of road safety and, as a result, to injury of the road users.

Conclusions

The proposed method for calculating the distribution of normal reactions between the axles of an n -axle wheeled vehicle allows taking into account the design features of the car suspension when determining the adhesion utilization curves on its respective axles.

The universality of the proposed methodology for calculating the distribution of normal reactions between axles of an n -axle wheeled vehicle makes it possible to optimize the process of assessing the distribution of brake forces of a vehicle, both with a balancing trolley and with vehicle axles independent of each other.

The developed methodology for calculating the distribution of normal reactions between the axles of an n -axle wheeled vehicle can be used in engineering calculations when testing multi-axle vehicles for compliance with the international requirements of brake systems, Appendix 10 to Regulation No. 13 UN / ECE.

The performed calculations of the adhesion utilization curves, using the example of a 4-axle WV, showed that consideration of the design features of the multi-axle wheeled vehicle suspension significantly affects the nature of the geometry of the adhesion utilization curves within the permissible limits established by UN / ECE Regulation No. 13 (Appendix 10).

Analysis of the average deviation in the results of calculating the adhesion utilization curves with an error not exceeding 1.5 % for the WV in running order and 3 % for the WV in loaded state showed that the nature of the geometry of the adhesion utilization curves within the zone established by international rules UN / ECE No. 13 depends significantly on the type of a multi-axle wheeled vehicle suspensions.

References

- 1 Regulation No 13 of the Economic Commission for Europe of the Combined Nations (UN/ECE) Uniform provisions concerning the approval of vehicles of categories M, N and O with regard to braking: on condition 18.02.2016 // Official Journal of the European Union. UN/ECE, 2016. — 262 p.
- 2 ГОСТ Р 41.13–2007. Единые предписания, касающиеся транспортных средств категорий *M, N и O* в отношении торможения. — М.: Стандартинформ, 2009. — 170 с.
- 3 Zalohin M.Y. Study of Proportional Pressure Modulator on the Basis of Electromagnetic-Type Linear Motor / M.Y. Zalohin, B.A. Liubarskiy, S.N. Schuklinov, M.G. Mychalevych, D.V. Leontiev // Science & Technique. — 2018. — 17(5). — P. 440–446.
- 4 Leontiev D. N. About Application the Tyre-Road Adhesion Determination of a Vehicle Equipped with an Automated System of Brake Proportioning / D. N. Leontiev, L. A. Ryzhyh, S. I. Lomaka, I. N. Nikitchenko, O. I. Voronkov, I. V. Hritsuk, S.V. Pylshchik, O. V. Kuripka // Science & Technique. — 2019. — 18(5). — P. 401–408.
- 5 Bogomolov V. Improving the brake control effectiveness of vehicles equipped with a pneumatic brake actuator / V. Bogomolov, V. Klimenko, D. Leontiev, L. Ryzhyh, O. Smyrnov, M. Kholodov // Science & Technique. — 2020. — 19(1). — P. 55–62.
- 6 Shaoyi B. Adhesion state estimation based on improved tire brush model / B. Shaoyi, L. Bo, Z. Yanyan // Advances in Mechanical Engineering. — 2018. — 10(1). — P. 1–9. doi: 10.1177/1687814017747706
- 7 Meljnikov D. Use of Simpack at the DaimlerChrysler Commercial Vehicles Division. Truck Product Creation (4P) / D. Meljnikov // Daimler Chrysler. — 2006. — 16 p.
- 8 Jazar R.N. Tire Dynamics / R.N. Jazar // Vehicle Dynamics: Theory and Application, Berlin, Springer. — 2008. — P. 95–163.
- 9 Braun O. M. On the Dependency of Friction on Load: Theory and Experiment / O. M. Braun, B. N. Persson, B. Steenwyk, A. Warhadpande // EPL (Europhysics Letters). — 2016. — 113 (5). https://doi.org/10.1209/0295-5075/113/56002.
- 10 The tyre. Grip / Michelin Technology Society. — France: Clermont-Ferrand. — 2001. — 96 p.
- 11 Li Shengbo Predictive lateral control to stabilise highly automated vehicles at tire-road friction limits / Li Shengbo, Chen Hailiang, Li Renjie, Liu Zhengyu, Wang Zhitao, Xin Zhe // Vehicle System Dynamics. — 2020. — 58:5. — P.768–786. 58, DOI: 10.1080/00423114.2020.1717553.
- 12 Bode O. Possibilities and Limits of a Simple Tire-road Adhesion Determination — Represented at the Example of Brake Testing in Accordance with ECE-R 13 / O. Bode // Hannover Conference on Tires, Chassis, Roads. — 2001. — P. 69–86.
- 13 Miao Yu Tire-Pavement Friction Characteristics with Elastic Properties of Asphalt Pavements / Miao Yu, Guoxiong Wu, Lingyun Kong, Yu Tang // Applied Sciences. — 2017. — 7(11).
- 14 Artyomov N. Analyzing the dynamics of a single car wheel / N. Artyomov, M. Podrigalo, A. Abdulgaziz // MATEC Web of Conferences 224, 02102, 2018. https://doi.org/ 10.1051/mateconf/201822402102

15 Kashkanov A. A. Inertial evaluation of the tyre-road interaction during emergency braking / A. A. Kashkanov, V.M. Diorditsa, V. Yu. Kucheruk, D. Zh. Karabekova, A. K. Khassenov, A. M. Sharzadin // Bulletin of the university of Karaganda-Physics. — 2019. — 2(94). — P. 82–91. DOI: 10.31489/2019Ph2/82–91.

16 Kashkanov A. A. Tyre-Road friction Coefficient: Estimation Adaptive System / A. A. Kashkanov, A. P. Rotshtein, V.Yu. Kucheruk, V. A. Kashkanov // Bulletin of the university of Karaganda-Physics — 2020. — 2(98). — P. 50–59. DOI: 10.31489/2020Ph2/50–59.

17 Saraiev O. Mathematical Model of the Braking Dynamics of a Car / O. Saraiev, Y. A. Gorb // SAE Technical Paper 2018–01–1893. — 2018. <https://doi.org/10.4271/2018-01-1893>

18 Туренко А.М. Функціональний розрахунок гальмівної системи автомобіля з барабанными гальмами та регулятором гальмівних сил / А.М. Туренко, В.О. Богомоллов, В.І. Клименко, С.Я. Ходирев, В.І. Кирчатий, М.Г. Михалевич // — Харків: ХНАДУ, 2003. — 120 с.

19 Leontiev D. Simulation of Working Process of the Electronic Brake System of the Heavy Vehicle / D. Leontiev, V. Klimenko, M. Mykhalevych, Y. Don, A. Frolov // Advances in Intelligent Systems and Computing. — 2020. — Vol.1019. — P. 50–61. Springer, Cham. DOI: 10.1007/978-3-030-25741-5_6

20 Методичні рекомендації з визначення осьових навантажень транспортних засобів з урахуванням сил, що діють у плямі контакту шини з поверхнею дорожнього одягу. МР В.2.3–37641918–887:2017. — Київ: Укравтодор, 2017. — 31 с.

21 Аксенов П.В. Многоосные автомобили / П.В. Аксенов. — 2-е изд. перераб. и доп. — М.: Машиностроение, 1989. — 280 с.

22 Провести дослідження та розробити методичні рекомендації з визначення осьових навантажень багатівісних транспортних засобів з урахуванням сил тертя в площі контакту шини з дорожнім покриттям. Звіт про науково-дослідну роботу за договором № 5/35–79–16. Науковий керівник д.т.н., проф. Жданюк В.К. — № держреєстрації 0116U005525. — ХНАДУ. — 2017. — 159 с.

23 Ротенберг Р.В. Подвеска автомобиля и его колебания: учеб. // Р.В. Ротенберг. — М.: Mashgiz, 1960. — 356 с.

24 Понизовкин А.Н. Краткий автомобильный справочник // А.Н. Понизовкин, Ю.М. Власко, М.Б. Ляликов и др. — М.: АО «Трансконсалтинг»; НИИАТ, 1994. — 779 с.

В.А. Богомоллов, В.И. Клименко, Д.Н. Леонтьев,
С.В. Поникаровская, А.А. Кашканов, В.Ю. Кучерук

Көпосьті көлік құралдары үшін ілінісуді жүзеге асыратын қисықтарды құру туралы

Жұмыста көпосьті доңғалақты көлік құралының осьтері бойымен жолдың тірек бетінің қалыпты реакцияларын есептеу әдісі ұсынылды, оның негізінде автомобильдің суспензиясында тәуелсіз осьтердің де, тепе-теңдік арбаларына біріктірілген осьтердің де болуын ескере отырып, көлік құралының барлық осьтері бойынша ілінісу қисықтарын құруға болады. Бұл әдістің негізгі идеясы көпосьті автомобиль корпусының серпімділік орталығының (айналу орталығының) көлденең координатасын анықтаудың әмбебап математикалық моделін жасау болып табылады, соның негізінде көлік құралының осьтері бойымен қалыпты реакциялар оның тежелу процесінде анықталады, ал тежегіш күштердің белгілі таралуымен жүзеге асырылатын ілінісу қисықтары да тұрғызылады. Шолу бөлімінде бүгінгі күні көп білікті доңғалақты көлік құралының осьтеріндегі жолдың қалыпты реакцияларын анықтауға қатысты бірыңғай әдістеме немесе ұсыныстар жоқ екенін көрсететін талдау келтірілген. Өзірленген әдістеме көп білікті доңғалақты көлік құралдарының тежегіш жүйелерге қойылатын халықаралық талаптарға сәйкестігін тексеру кезінде инженерлік есептеулерде қолданылуы мүмкін (UN/ECE №13 Ережесінің 10-шы қосымшасы). Ұсынылған әдістеменің әмбебаптығы жоғарыда аталған Ережелерді енгізуде ұсыныс жасауға мүмкіндік береді. Төрт осьті көлік құралының мысалында жүзеге асырылатын ілінісу қисықтарының орындалған есептеулері көпосьті доңғелекті көлік құралының аспа құрылымының ерекшеліктерін есепке алу UN/ECE №13 Ережелерінде (10 Қосымша) белгіленген рұқсат етілген шектеулер шегінде жүзеге асырылатын ілінісу қисықтарының орналасу сипатына айтарлықтай әсер ететінін көрсетті.

Кілт сөздер: көпосьті көлік құралы, тежегіш күштердің таралуы, тежегіш күші, тежеу тиімділігі, ілінісу қисықтары, жоғары жылдамдықты автомобиль, көпосьті.

В.А. Богомоллов, В.И. Клименко, Д.Н. Леонтьев,
С.В. Поникаровская, А.А. Кашканов, В.Ю. Кучерук

О построении кривых реализуемого сцепления для многоосных транспортных средств

Предложен метод расчета нормальных реакций опорной поверхности дороги по осям многоосного колесного транспортного средства, на основе которого можно построить кривые реализуемого сцепле-

ния по всем осям транспортного средства с учетом наличия в подвеске автомобиля как независимых осей, так и осей, объединенных в балансирные тележки. Основная идея этого метода заключается в разработке универсальной математической модели определения горизонтальной координаты центра упругости (центра поворота) кузова многоосного автомобиля, на основе чего и определяются нормальные реакции по осям транспортного средства в процессе его торможения, а при известном распределении тормозных сил строятся и кривые реализуемого сцепления. В обзорной части приведены данные анализа, который показал, что на сегодняшний день отсутствуют единая методика или рекомендации в отношении определения нормальных реакций дороги на осях многоосного колесного транспортного средства. Разработанная методика может быть применена в инженерных расчетах при проверке многоосных колесных транспортных средств на соответствие международным требованиям к тормозным системам (Приложение 10 к Правилам № 13 UN/ECE). Универсальность предложенной методики позволяет рекомендовать ее к внедрению в указанных выше Правилах. Расчеты кривых реализуемого сцепления на примере четырехосного транспортного средства показали, что учет особенностей конструкции подвески многоосного колесного транспортного средства существенно влияет на характер расположения кривых реализуемого сцепления в пределах допустимых ограничений, установленных Правилами № 13 UN/ECE.

Ключевые слова: многоосное транспортное средство, распределение тормозных сил, тормозная сила, эффективность торможения, кривые реализуемого сцепления, автомобиль повышенной проходимости, многоосник.

References

- 1 UN/ECE. (2016). Regulation № 13 of the Economic Commission for Europe of the United Nations (UN/ECE) — Uniform provisions concerning the approval of vehicles of categories M, N and O with regard to braking: on condition 18.02.2016 — Official Journal of the European Union.
- 2 HOST R 41.13–2007. (2009). *Edinoobraznye predpisaniia, kasaiuschiesia transportnykh sredstv katehorii M, N i O v otnoshenii tormozheniia [Uniform regulations concerning M, N and O vehicles for braking]*. Moscow: Standartinform [in Russian].
- 3 Zalohin, M.Y., Liubarskyi, B.A., Schuklinov, S.N., Mychalevych, M.G., & Leontiev, D.V. (2018). Study of Proportional Pressure Modulator on the Basis of Electromagnetic-Type Linear Motor. *Science & Technique*, 17(5), 440–446.
- 4 Leontiev, D.N., Ryzhyh, L.A., Lomaka, S.I., Nikitchenko, I.N., Voronkov, O.I., Hritsuk, I.V., et al. (2019). About Application the Tyre-Road Adhesion Determination of a Vehicle Equipped with an Automated System of Brake Proportioning. *Science & Technique*, 18(5), 401–408.
- 5 Bogomolov, V., Klimenko, V., Leontiev, D., Ryzhyh, L., Smyrnov, O., & Kholodov M. (2020). Improving the brake control effectiveness of vehicles equipped with a pneumatic brake actuator. *Science & Technique*, 19(1), 55–62.
- 6 Shaoyi, B., Bo, L., & Yanyan, Z. (2018). Adhesion state estimation based on improved tire brush model. *Advances in Mechanical Engineering*, 01. doi:10.1177/1687814017747706
- 7 Meljnikov, D. (2006). Use of Simpack at the DaimlerChrysler Commercial Vehicles Division. *Truck Product Creation (4P)*. DaimlerChrysler.
- 8 Jazar, R.N. (2008). *Tire Dynamics*. *Vehicle Dynamics: Theory and Application*, Berlin, Springer, 95–163.
- 9 Braun, O. M., Persson, B. N., Steenwyk, B., & Warhadpande, A. (2016). On the Dependency of Friction on Load: Theory and Experiment. *EPL (Europhysics Letters)*, 113 (5), <https://doi.org/10.1209/0295-5075/113/56002>.
- 10 The tyre. Grip. (2001). Michelin Technology Society, France, Clermont-Ferrand.
- 11 Li, Shengbo, Chen, Hailiang, Li, Renjie, Liu, Zhengyu, Wang, Zhitao, & Xin, Zhe. (2020). Predictive lateral control to stabilise highly automated vehicles at tire-road friction limits. *Vehicle System Dynamics*, 58, 768–786. DOI: 10.1080/00423114.2020.1717553
- 12 Bode, O. (2001). Possibilities and Limits of a Simple Tire-road Adhesion Determination — Represented at the Example of Brake Testing in Accordance with ECE-R 13. Hannover Conference on Tires, Chassis, Roads, Hannover, Germany, 69–86.
- 13 Miao, Yu, Guoxiong, Wu, Lingyun, Kong, & Yu, Tang (2017). Tire-Pavement Friction Characteristics with Elastic Properties of Asphalt Pavements. *Applied Sciences*, 7(11).
- 14 Artyomov, N., Podrigalo, M., & Abdulgazis, A. (2018) Analyzing the dynamics of a single car wheel. *MATEC Web of Conferences* 224, 02102, <https://doi.org/10.1051/mateconf/201822402102>.
- 15 Kashkanov, A. A., Diorditsa, V. M., Kucheruk, V. Yu., Karabekova, D. Zh., Khassenov, A. K., & Sharzadin, A. M. (2019). Inertial evaluation of the tyre-road interaction during emergency braking, *Bulletin of the university of Karaganda-Physics*. 2(94), 82–91. <https://doi.org/10.31489/2019Ph2/82-91>.
- 16 Kashkanov, A. A., Rotshtein, A. P., Kucheruk, V. Yu., & Kashkanov, V. A. (2020). Tyre-Road friction Coefficient: Estimation Adaptive System. *Bulletin of the university of Karaganda-Physics*. 2(98). P. 50–59. DOI: 10.31489/2020Ph2/50-59.
- 17 Saraiev, O., & Gorb, Y. (2018). A Mathematical Model of the Braking Dynamics of a Car. *SAE Technical Paper* 2018-01-1893. <https://doi.org/10.4271/2018-01-1893>.
- 18 Функціональні розрахунки халмивної системи автотранспорту з барабанными халми та регулятором халмивних сил [Functional calculation of the car brake system with drum brakes and regulator of braking forces]. (2003). / [A.M. Turenko, V.O. Bohomolov, V.I. Klymenko ta insh.] — Kharkiv: KhNADU [in Ukrainian].
- 19 Leontiev, D., Klimenko, V., Mykhalevych, M., Don, Y., & Frolov, A. (2020) Simulation of Working Process of the Electronic Brake System of the Heavy Vehicle. *Advances in Intelligent Systems and Computing*, 1019, P. 50–61. Springer, Cham. DOI: 10.1007/978-3-030-25741-5_6

20 Metodichni rekomendatsii z vyznachennia osovykh navantazhen transportnykh zasobiv z urakhuvanniam syl, shcho diut u pliami kontaktu yoho shyn z poverkhneiu dorozhnoho odiahu [Methodological recommendations for determining the axial loads of vehicles taking into account the forces acting in the spot of contact of its tires with the road surface]. (2017). MR V.2.3–37641918–887:2017. Kyiv: Ukravtodor [in Ukrainian].

21 Aksenov, P.V. (1989). *Mnohoosnye avtomobili [Multi-axle vehicles]*. (2d Ed.). Moscow: Mashinostroenie [in Russian].

22 Zhdaniuk, V.K. (2017). Provesty doslidzhennia ta rozrobyty metodichni rekomendatsii z vyznachennia osovykh navantazhen bahatovisnykh transportnykh zasobiv z urakhuvanniam syl tertia v ploshchi kontaktu shyny z dorozhnim pokryttiam [Carry out research and develop methodological recommendations for determining axial loads of multi-axle vehicles, taking into account the friction forces in the contact area of the tire with the road surface]. *Zakliuchnyi zvit pro naukovo-doslidnu robotu za temoiu № 5/35–79–16 / Kharkivskiy natsionalnyi avtomobilno-dorozhnyi universytet. № DR 0116U005525* [in Ukrainian].

23 Rotenberg, R.V. (1960). *Podveska avtomobilia i eho kolebania [Suspension of the car and its oscillations]*. Moscow: Mashhiz [in Russian].

24 Ponizovkin, A.N., Vlasko, Yu. M., & Lyalikov, M.B. et al. (1994). *Kratkii avtomobilnyi spravochnik [A brief car directory]*. Moscow: AO «Transkonsaltinh»; NIIAT [in Russian].

BUKETOV UNIVERSITY