

UDC 621.7

B.A. Akhmadiev<sup>1,2</sup>, A. Tatybekov<sup>2</sup>, N.N. Shuyushbayeva<sup>3</sup>,  
N.K. Tanasheva<sup>5</sup>, G.S. Altayeva<sup>3</sup>, M. Stoev<sup>4</sup>

<sup>1</sup>*Ye.A. Buketov Karaganda State University, Kazakhstan;*

<sup>2</sup>*I. Razzakova Kyrgyz State Technical University, Bishkek, Kyrgyzstan;*

<sup>3</sup>*Sh.Ualikhhanov Kokshetau State University, Kazakhstan;*

<sup>4</sup>*South-West University «Neofit Rilsky», Blagoevgrad, Bulgaria;*

<sup>5</sup>*Institute of Applied Mathematics, Karaganda, Kazakhstan*

*(E-mail: nn\_shuish@mail.ru)*

### **Electrohydropulse technology of destruction and crushing of natural stones at different parameters**

The aim of the study is to develop scientific and practical principles of implementation of energy saving heat pump technology for heat and cold supply to residential, public and industrial premises on the basis of alternative and renewable sources of energy. One of the effective methods to generate heat from groundwater by means of heat pump technology is the use of wells for consolidation of heat exchange elements produced by drilling. Fundamentally new innovative method of making wells is electro-hydraulic drilling, when electrical energy directly in the bottomhole transforms into mechanical energy of shock waves that can break up rocks. This paper describes the results of studies of the impact of electro-hydraulic pulse on hard and superhard rock minerals. The quantitative dependency, characterizing the beginning of the process of destruction of rocks of various thickness depending on the number and energy of discharges was defined. The experimental work proved the possibility of achieving higher drilling speeds compared to those at conventionally used plants. The electric pulse destruction is implemented without using a drilling bit, it does not require special tightness of electrodes to bottomhole surface with considerable force; therefore, the wear of the electrodes at electro-hydraulic pulse drilling is relatively minor.

*Keywords:* Electrohydraulic drilling, hydraulic pressure, cavitation phenomena, pulse capacitor, high-voltage.

Has led the need for development of the new equipment, new highly effective technological processes and the equipment, means of mechanization and automation without which technical progress in mining industry became inconceivable to research and development of a number of new methods of destruction of the solid bodies based on various physical principles. The electropulse (EI) method of destruction of materials which essence consists in the destroying action of electric pulse discharges in solid nonconducting and semi-conducting bodies was one of the most perspectives.

Theoretical justification and laboratory researches EI of a way of the operated destruction of solid dielectrics and semiconductors which on the electrophysical properties the majority of natural stones is among is given by A.A. Vorobyov, G.A. Vorobyov, A.T. Chepikov et al.

Electrohydraulic drilling is essentially new way and hasn't found industrial application yet, the research problem and practical introduction of this technology remains relevant today.

Unique advantage of this technology are a possibility of work in the conditions of the limited spatial volume (the built buildings, the covered rooms, cellars, etc.) that is almost impossible when using traditional methods of drilling owing to bulkiness of the equipment. And also long reliable work due to lack of the rub-

bing and wearing out parts of installation and simplicity in operation and service that is provided with application as an active part of a generally available cable – an electrode – being an expendable material [1-3].

This technology, in comparison with traditional, allows more effectively and in short terms to destroy obstacles in the form of strong breeds at well-drilling of heat exchangers by influence by shock waves at high-voltage categories in the water environment [4].

The electrohydraulic effect represents high-voltage electric discharge in the liquid environment. When forming electric discharge in liquid allocation of energy happens during rather short period. The powerful high-voltage electric impulse with the abrupt forward front causes various physical phenomena. Such as emergence of ultrahigh pulse hydraulic pressure, electromagnetic radiation in a wide range of frequencies up to, under certain conditions, to x-ray, the cavitation phenomena [5]. The electrohydropulse phenomena as a physical basis of various electrotechnologies it is rather well studied [6].

Electric energy in mechanical without intermediate links with high efficiency it is possible to carry out transformation on the basis of electrohydraulic effect (blow). The high-voltage pulse category in liquid can be considered in the following sequence: electric breakdown and formation of the channel of the category, allocation of energy in the channel, strengthening of shock, ultrasonic and sound waves, the expansion of a cavity which is followed by generation of an impulse of pressure with formation of the dispersing liquid stream, a cavity pulsation. The electrohydraulic category arises at the annex to liquid of pulse tension of sufficient amplitude and duration therefore electric breakdown develops.

Electrohydropulse installation can carry out works in the following conditions: air temperature from 288 K to 313 K to from (+15<sup>0</sup> to +40 °C); relative humidity of air no more than 80 % at a temperature of 303 K (+30 °C);

Structurally the device will be executed in the form of the functional blocks consisting of the control panel, the condenser with the system of protection, the generator of pulse currents with the switchboard. The main knots of electrohydropulse installation are given in the Figure 1.

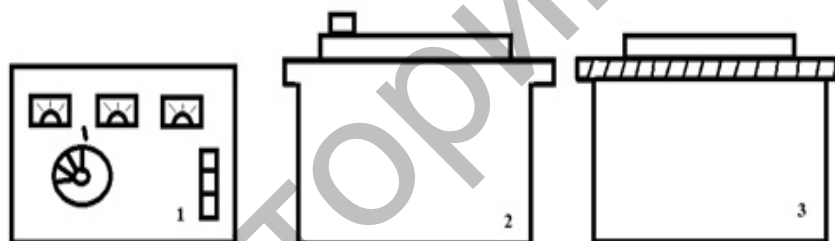

1 — control panels; 2 — system of protection with the condenser; 3 — generator with the arrester

Figure 1. EGIU main hubs

In the Figure 2 the scheme of creation of electrohydraulic pulses is submitted.

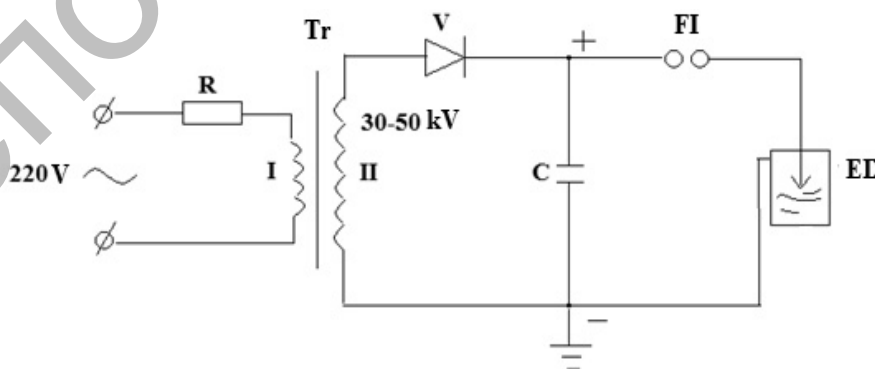

R — digit resistance; Tr — the high-voltage transformer; V — the rectifier; C — pulse capacitor; FI — the forming interval; ED — an electrohydropulse drill

Figure 2. The scheme of creation of electrohydro pulses shock with one forming interval

On (+) and (-) an exit parallel to the transformer the condenser under connects. Alternating voltage moves through digit resistance on primary winding of the raising transformer, on a secondary winding of the transformer there is a high voltage which becomes straight via the rectifier, further the direct current moves on the condenser. Tension on the condenser increases to a certain value at which energy through FP arrives on a working interval of ED where there is a high-voltage category in liquid, further process repeats with a certain frequency. Frequency of impulses changes depending on the output tension of the transformer, capacity of the condenser and distance in FI.

Figure 3 shows scheme of the electro-hydraulic drilling.

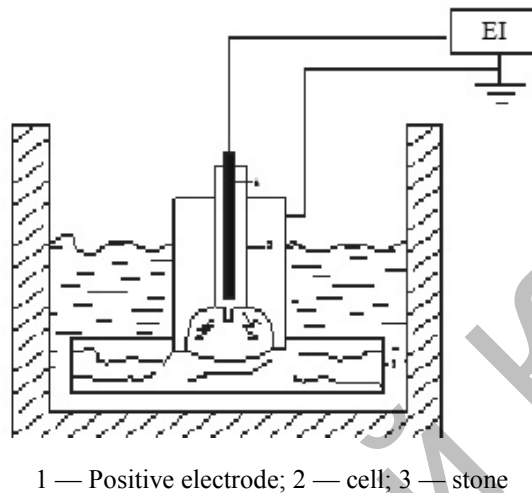

Figure 3. Scheme of the electro-hydraulic drilling

As a result of laboratory researches drilling parameters at which owing to increase in pressure, impact of a shock wave on stone soil leads to essential increase of intensity of lumpy crushing have been set.

Experiments were carried out for minerals of various structure and content. Figure 4 and 5 shows comparative graphs number of impact discharges for different capacitors at stone thickness of 60–70 mm) depending on the variation of the initial voltage  $U_0$  at constant capacitance of capacitor banks.

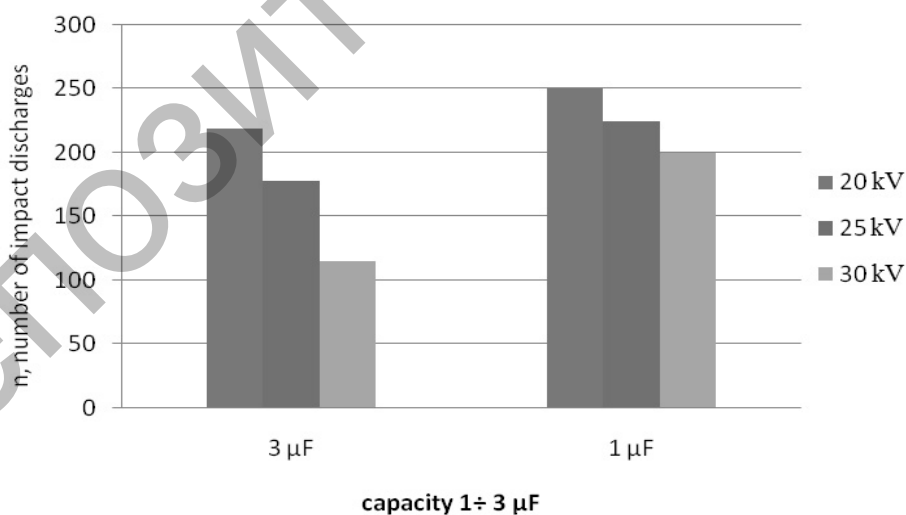

Figure 4. Comparative graph number of impact discharges for different capacitors (a stone thickness of 60 mm)

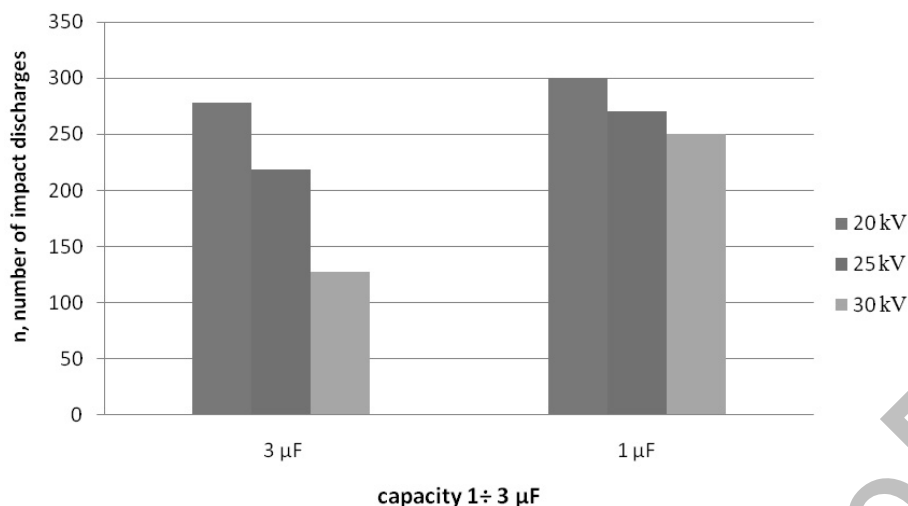

Figure 5. Comparative graph number of impact discharges for different capacitors (a stone thickness of 70 mm)

The results of laboratory technological experiments lead to the following conclusion: the maximum benefit from the use of electrical discharges for the destruction of natural stones is observed at the following parameters of the discharge circuit of a high-voltage pulse generator:  $U_0=35\text{ kV}$ ,  $C=3\text{ }\mu\text{F}$ ,  $l_{eg}=12\text{ mm}$ .

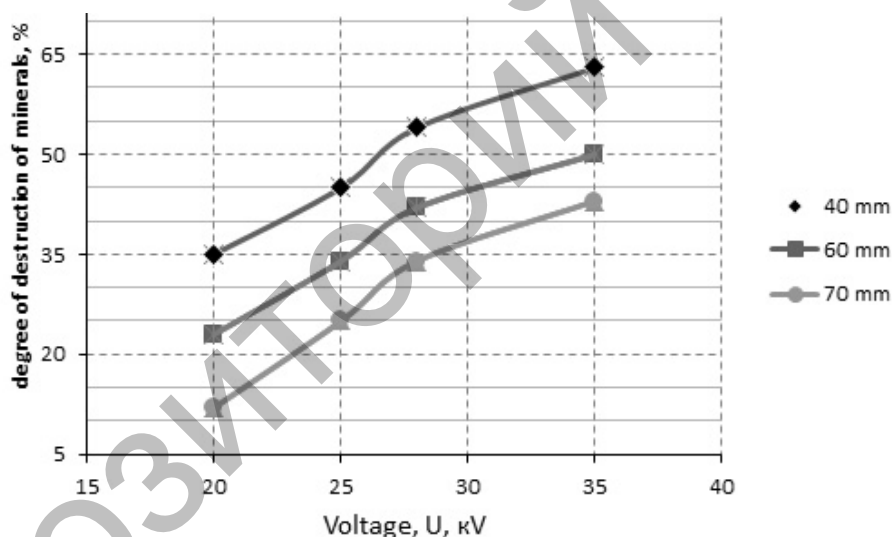

Figure 6. Voltage of digit contour of 20 ÷ 35 kV, Degree of destruction of minerals

It is defined that at a voltage of digit contour of 20 ÷ 35 kV, capacity 1 ÷ 3 μF, interelectrode distance of 7 ÷ 12 mm, destruction of stony soil of the well is in vitro most effective; in experiments the number of spark electrocategories and their frequency necessary for electrohydraulic drilling of the set thickness of stone soil is defined (Fig. 6) [7]. It is shown that funnel depth in stone soil in direct ratio depends on the number of spark categories. From here, parameters of shock waves which at the movement in breed cause violation of her continuity. And extent of destruction of rock, directly depend on electric characteristics of the channel of breakdown: tension of  $U$ , current of  $I$ , resistance of the channel of category  $R$ , time of course of current of  $t$ , power of  $P$  and energy of  $W$  emitted in the channel of the category.

On the basis of experimental studies we established limits for electrophysical parameters of the method, at which the intensive destruction of solid rock, i. e. natural stones starts.

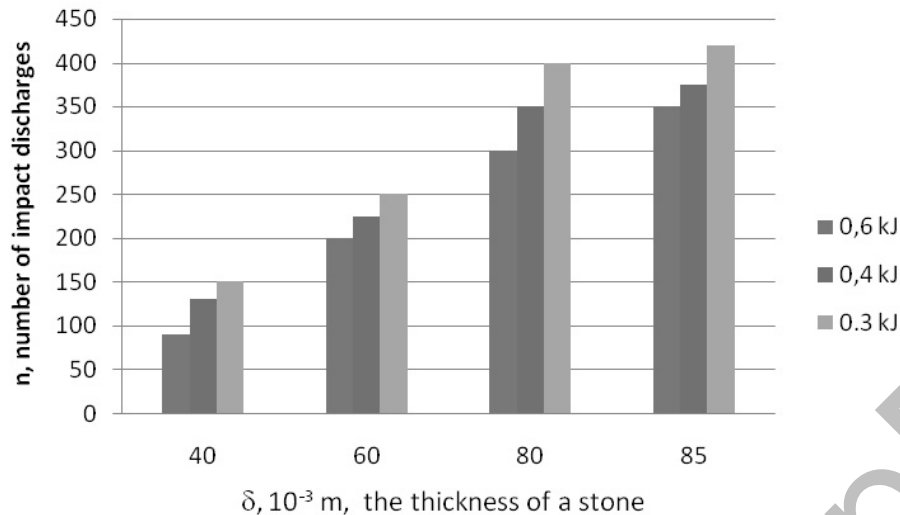

Figure 7. Optimal energy level of natural materials failure depending on their thickness

Optimum energy for breaking stones is from 0,3 kJ to 0,6 kJ. When discharge energy increases up to 612 J, a complete destruction of stones is observed (Fig.7). This fact proves the existence of some optimum value of the electric discharge energy.

Drilling depth depends on the number of impact discharges. At the maximum impact discharge, the rate of increase in drilling depth grows. The reason is that at the impact discharge an increase in pressure takes place, it causes the lump grinding on the surface of a stone. An increase in the impact of a discharge leads to pressure growth, so at the maximum impact of an electric discharge the depth of drilling is increased.

Using a result of the experimental study, the authors have defined the optimal values of electro-physical parameters, within which the intensive destruction of solid and super solid rocks starts. The dependence graphs characterizing the beginning of the process of destruction of rocks of different thickness depending on the number and energy discharges are plotted.

#### References

- 1 Кусаинов К. Разработка электрогидроимпульсной технологии бурения скважин для установки теплосъемных элементов тепловых насосов / К. Кусаинов, Н.Н. Шуюшбаева, К.М. Турдыбеков, Ж.А. Кужуханова // Современная наука: исследования, идеи, результаты, технологии. — 2013. — № 2(13). — С. 420–425.
- 2 Кусаинов К., Шуюшбаева Н.Н., Турдыбеков К.М., Ахмадиев Б.А. Электрогидроимпульсная технология разрушения природных минералов при бурении теплообменных скважин // Деформация разрушения материалов и наноматериалов: V Междунар. конф. (26—29 ноября 2013 г.). — М., 2013. — С. 660–662.
- 3 Kussainov K Electro—pulse technology of production heat exchangers for extracting the heat from the ground at shallow depths / K. Kussainov, S.E. Sakipova, N.N. Shuyushbayeva, B.A. Ahmadiev, J.A. Kuzhuhanova // Eurasian Physical Technical Journal. — 2012. — Vol. 9. — № 2(18). — P. 19–23.
- 4 Кусаинов К. Энергоэффективность электрогидравлического бура при создании скважин для теплообменных аппаратов / К. Кусаинов, Н.Н. Шуюшбаева, Б.А. Ахмадиев, Ж.А. Кужуханова // Вестн. Караганд. ун-та. Сер. Физика. — 2014. — № 1(73). — С. 39–45.
- 5 Юткин Л.А. Электрогидравлический эффект / Л.А. Юткин. — М.: Машгиз, 1955. — С. 51.
- 6 Юткин Л.А. Электрогидравлический эффект и его применение в промышленности / Л.А. Юткин. — Л.: Машиностроение, 1986. — С. 253.
- 7 Kussainov K. Optimization of technology of natural material destruction in the course of electrohydropulse drilling. Modeling for Electromagnetic Processing / K. Kussainov, N.N. Shuyushbayeva, K.M. Turdybekov, B.A. Ahmadiev // International Scientific Colloquium (September 16–19). — Hannover, 2014. — P. 345–349.

Б.А. Ахмадиев, А. Татыбеков, Н.Н. Шуюшбаева, Н.К. Танашева, Г.С. Алтаева, М. Стоев

### **Әртүрлі көрсеткіштерде табиғи тастарды бұзу және ұсақтаудың электргидроимпульстік технологиясы**

Зерттеудің мақсаты баламалы және жаңартылатын энергия көздері негізінде тұрғын үй, қоғамдық және өндірістік үй-жайларды жылу және суық жеткізу үшін энергияны үнемдейтін жылу сорғысы технологиясын енгізудің ғылыми және практикалық қағидаларын әзірлеу болып табылады. Жылулық сорғы технологиясымен жер асты суларынан жылу алудың тиімді әдістерінің бірі — бұрғылау арқылы шығарылатын жылу элементтерін шоғырландыру үшін ұңғымаларды пайдалану қажет. Ұңғымаларды құрудың түбегейлі жаңа инновациялық әдісі — электргидравликалық бұрғылау, бұл кезде электр қуаты тікелей ұңғымада тау жыныстарын бұза алатын соққы толқындарының механикалық энергиясына айналады. Мақалада электргидроимпульстің қатты және аса қатты жыныстарға әсері туралы зерттеулердің нәтижелері сипатталған. Әртүрлі қалыңдықтағы тау жыныстарының разрядтар саны мен энергиясына тәуелді ұсақталу үдерісінің басталуын сипаттайтын сандық тәуелділіктер анықталған. Тәжірибе жүзінде дәстүрлі бұрғылау қондырғыларына қарағанда бұрғылаудың бұл түрі жоғары бұрғылау жылдамдығына жету мүмкіндігіне ие болатындығы дәлелденді. Бұл кезде электримпульстік ұсақтау қашаусыз іске асырылады, ол ұңғыма түбіне электродтарды күштеп басуды қажет етпейді. Сондықтан электргидроимпульстік бұрғылау кезінде электродтардың желінуі салыстырмалы түрде аз болып табылады.

*Кілт сөздер:* электргидравликалық бұрғылау, гидравликалық қысым, кавитациялық құбылыстар, импульстік конденсатор, жоғарғывольтті.

Б.А. Ахмадиев, А. Татыбеков, Н.Н. Шуюшбаева, Н.К. Танашева, Г.С. Алтаева, М. Стоев

### **Электрогидроимпульсная технология разрушения и измельчения природных камней при разных параметрах**

Целью исследования является разработка научных и практических принципов внедрения энергосберегающей технологии тепловых насосов для тепло- и холодоснабжения в жилых, общественных и производственных помещениях на основе альтернативных и возобновляемых источников энергии. Одним из эффективных способов получения тепла из подземных вод с помощью технологии тепловых насосов является использование скважин для уплотнения теплообменных элементов, образующихся при бурении. Принципиально новым инновационным методом создания скважин является электрогидравлическое бурение, когда электрическая энергия непосредственно в забое преобразуется в механическую энергию ударных волн, которые могут разрушать породы. В настоящей работе описываются результаты исследований влияния электрогидравлического импульса на твердые и сверхтвердые горные минералы. Установлены количественные зависимости, характеризующие начало процесса разрушения горных пород разной толщины в зависимости от количества и энергии разрядов. Опытными работами была доказана возможность достижения более высокой скорости бурения, чем на традиционно используемых установках. Электроимпульсное разрушение является бездолотным, оно не требует специального прижатия электродов к забою со значительным усилием, а потому износ электродов при электрогидроимпульсном бурении сравнительно мал.

*Ключевые слова:* электрогидравлическое бурение, гидравлическое давление, кавитационные явления, импульсный конденсатор, высоковольтный.

#### References

- 1 Kussaiynov, K., Shuyushbayeva, N.N., Turdybekov, K.M., & Kuzhukhanova, Zh.A. (2013). Razrabotka elektrohimpulsnoi tekhnologii bureniia skvazhin dlia ustanovki teplosemnykh elementov teplovykh nasosov [Development of electrohydropulse technology of well-drilling for installation of heatremovable elements of thermal pumps]. *Sovremennaiia nauka: issledovaniia, idei, rezultaty, tekhnologii – Modern science: researches, ideas, results, technologies*, 2, 13, 420–425 [in Russian].
- 2 Kussaiynov, K., Shuyushbayeva, N.N., Turdybekov, K.M., & Akhmediyev, B.A. (2013). Elektrohimpulsnaia tekhnologiya razrusheniia prirodnykh mineralov pri burenii teploobmennykh skvazhin [Electrohydropulse technology of destruction of natural minerals when drilling heatexchange wells]. *Proceedings from Deformation of destruction of materials and nanomaterials: V mezhdunarodnaia konferentsiia (26-29 noiabria, 2013 hoda) – V International conference*. (pp. 660–662). Moscow [in Russian].
- 3 Kussaiynov, K., Sakipova, S.E., Shuyushbayeva, N.N., Ahmadiev, B.A., Kuzhuhanova, J.A. (2012). Electro-pulse technology of production heat exchangers for extracting the heat from the ground at shallow depths. *Eurasian Physical Technical Journal*, Vol. 9, 2, 18, 19–23.
- 4 Kusaiynov, K., Shuyushbayeva, N.N., Akhmediyev, B.A., Kuzhukhanova, Zh.A. (2014). Energoeffektivnost elektrohivavlichesko bura pri sozdanii skvazhin dlia teploobmennykh apparatov [Energoeffektivnost of an electrohydraulic drill

during creation of wells for heatexchange devices]. *Vestnik Karahandinskoho universiteta. Seriya Fizika – Bulletin of the Karaganda University. Physics series*, 1(73), 39–45 [in Russian].

5 Yutkin, L.A. (1955a). *Elektrohidravlicheskiy effekt [Electrohydraulic effect]*. Moscow: Mashhiz [in Russian].

6 Yutkin, L.A. (1986b). *Elektrohidravlicheskiy effekt i ego primeneniye v promyshlennosti [Electrohydraulic effect and its application in the industry]*. Leningrad: Mashinostroenie [in Russian].

7 Kussaiynov, K., Shuyushbayeva, N.N., Turdybekov, K.M., Ahmadiev, B.A. (2014). Optimization of technology of natural material destruction in the course of electrohydropulse drilling. Modelling for Electromagnetic Processing. *International Scientific Colloquium (September 16-19)*. (pp. 345–349). Hannover.

Репозиторий КАРГУ