

INVESTIGATION OF THE STRESS STATE OF MINE WORKINGS USING METHODS OF DEFORMABLE SOLID MECHANICS

Shaikhova G.S.¹, Belomestny D.V.², Kopbalina K.B.^{1*}

¹ A. Saginov Karaganda Technical University, Karaganda, Kazakhstan, kopbalina82@mail.ru

² University Duisburg-Essen, Germany, denis.belomestny@uni-due.de

The assessment of the reliability of a mining and technological scheme, taking into account the stress state of mine workings, depends on a combination of mining and geological, technical and technological factors. The article demonstrates the creation of a model of a rock mass and a scheme for calculating the stress state based on modern methods of mechanics of a deformable solid body. The object of study is a single mine working of great length, passed through the rock parallel to the strike of the coal seam (field drift) and located in the zone of influence of the support pressure. Due to the fact that the field drift is laid in the soil of the formation, which is a layered stratum in the zone of influence of clearing operations, the predominant load is the bearing pressure on the formation. The areas of application of the methods of complex potentials of integral equations and their combinations in solving applied problems are determined. The data of mine (field) measurements and observations, laboratory experiments and their generalizations are taken into account both when setting tasks and assigning boundary conditions, and when checking the results obtained. The mixed problem of the theory of elasticity about the contact stress on half-strips with varying along the longitudinal axis was solved; moving away from the ends, deformative properties, when these half-strips are clamped with friction between the layered half-planes.

Keywords: massif, stresses, model, coal seam, integration nodes, method of boundary integral equations, pressure.

Introduction

The aim of our study is: the selection of adequate models of such media in the form of a layered half-plane, anisotropic plane and half-strips between compressing heterogeneous half-planes, solving problems of the theory of elasticity for a layered half-plane with a hole and an anisotropic plane with two mutually affecting openings under given boundary conditions in the stresses; determination of contact stresses for half strips between clamped layered half-planes; establishing areas for the effective application of the methods of complex potentials of integral equations and their combinations in solving the applied problems. The following tasks are specifically set:

- to justify the reduction of the problem of the tensivity of the field drift in the zone of influence of coal seam mining by long columns in the fall to the first main plane problem of the theory of elasticity for a layered half-plane with a hole and a biconnected anisotropic plane;
- to determine the tensivity of the layered half-plane near the free circular hole with unbalanced loads at the upper boundary;
- to assess the distribution of contact tension on half-strips, divorced along the longitudinal axis and compressed by layered half-planes;
- to find the stress state of the anisotropic plane near a free hole of arbitrary shape at given voltages at infinity and on the contour of an elongated oblong hole;
- to perform multivariate calculations, analyze them and formulate practical recommendations.

The research methodology provides for the mandatory use of data from mine (full-scale) measurements and observations, laboratory experiments and their generalizations both in the formulation of tasks and the assignment of boundary conditions, and in verifying the results obtained during the solution. When solving boundary-value problems, both analytical and numerical methods of mechanics of a deformable solid are involved.

1. Research methodology

The correct choice of the method of maintaining the operational drifts located near the coal seam in working condition cannot be achieved without knowledge of the intense rock mass. A method for calculating stresses in the vicinity of a field preparatory drift based on the method of boundary integral equations for the theory of elasticity of an anisotropic body, taking into account the specifics of coal seam mining, is proposed. A diagram of the mutual arrangement of the grading and field drift is shown in Fig. 1. The rock mass is represented by an elastic homogeneous transversely isotropic body. The plane of isotropy of the body coincides with the bedding plane of the rocks, which makes an angle φ with the horizontal plane. We believe that in the vertical plane across the strike of the isotropy plane Oxy , the condition of plane deformation is fulfilled. The stresses in the pristine mass are homogeneous ($\sigma_x^0 = const$, $\sigma_y^0 = const$, $\tau_{xy}^0 = const$). The drift has a circular (R -radius) cross-section, the treatment output is rectangular (h -height, L -length).

Consider mining a coal seam by dip. Line KK' models the face moving along the formation. In this case, point K advances as coal are extracted from point A in a straight line DAE to the left (see Fig. 1). In real conditions, as the face moves in the vicinity of the mine working site, inelastic deformations develop, the roof settles down until it collapses completely [1-3]. So, in fig. 2 shows the pressure zone according to S.G. Avershin. It can be assumed that, over time, the destroyed and completely subsided rock masses establish stresses that coincide with the field of natural stresses of the rock mass (region $AA'B'B$, Fig. 2b). In the area $BB'C'C$ of voltage in the settled rocks have not been established, the area corresponds to the bottom hole zone, where coal is broken, people and mechanisms work.

The complexity of mathematical modeling of the coal seam mining process, even in the two-dimensional case, is due, first of all, to the presence of gaps of developing inelastic deformations. Direct consideration of these zones in the formulation of the problems of mechanics of a deformable solid leads to difficulties that are currently resolved only in some cases. Therefore, for simplicity of calculations, it makes sense to consider the problem in an elastic setting, taking into account the zones of destroyed rocks with the help of additional forces that act along the boundary of the mine. Based on the foregoing, the problem of determining the stress state of a rock mass can be described as a flat problem of the theory of elasticity of an anisotropic body. At the same time, we believe that, starting from a certain distance from the bottom (points C and C'), the forces increasing according to the linear law (on the lines CB and $C'B'$, see Figure 1) act on the boundary of the mine working. The forces increase until they reach a value characterizing the stresses in the untouched massif and then remain unchanged (on the lines BA , AA' , $A'B'$). The type of external forces characterizing the stresses in the untouched array is chosen from the following considerations. For simplicity, let us consider a single hole in an anisotropic plane loaded at “infinity” (Figure 3).

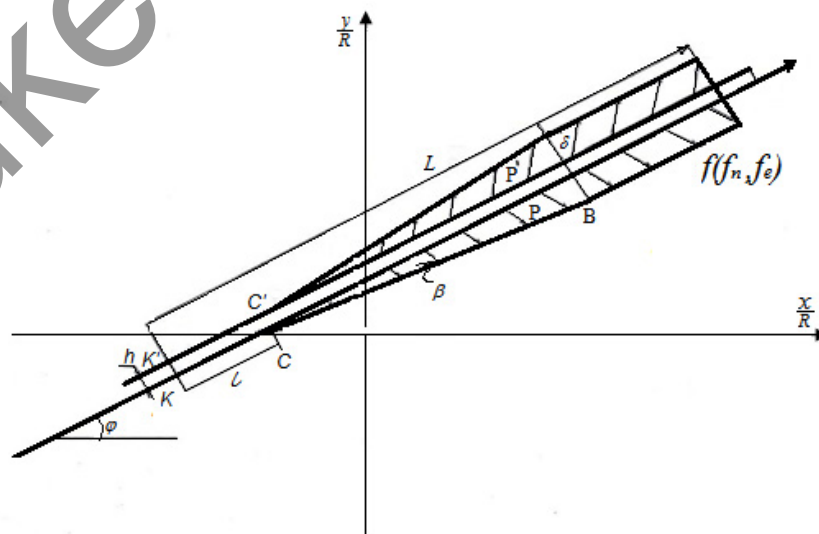

Fig.1. Scheme of the relative location of the treatment plant and drift.

The stress state of a plane is determined by the boundary element method [4,12]. In this case, we approximate the counter holes by a closed polygonal line consisting of line segments (elements). The resolving system of relative constant for each element of fictitious loads for the first main task of the theory of elasticity has the form.

$$\left. \begin{aligned} \sum_{j=1}^K (a_{nij} g_{nj} + a_{lij} g_{lj}) &= -\sigma_{ni}^0 - f_{ni}, \\ \sum_{j=1}^K (b_{nij} g_{nj} + b_{lij} g_{lj}) &= -\tau_{nli}^0 - f_{li} \end{aligned} \right\} \quad (i = 1, 2, \dots, K) \quad (1)$$

here g_{nj} and g_{lj} are the intensities of the friction loads; $a_{nij}, a_{lij}, b_{nij}, b_{lij}$ - system coefficients - are determined according to well-known formulas [5-7,11]; and σ_{ni}^0 , and τ_{nli}^0 voltage in a plane without a hole, converted accordingly for the i - element; f_{ni} and f_{li} respectively, the normal and tangential forces acting on the i - element; K - the number of approximating elements ($ij = 1, 2, \dots, K$).

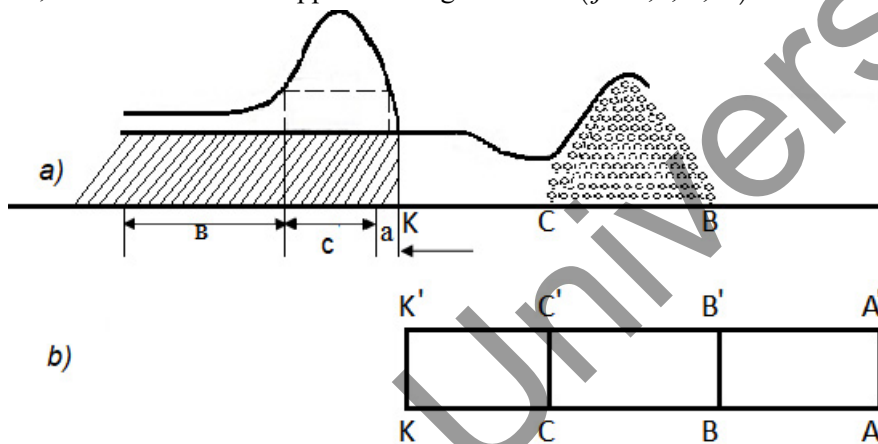

fig. 2. Characteristic areas in the worked – out space and their schematization.

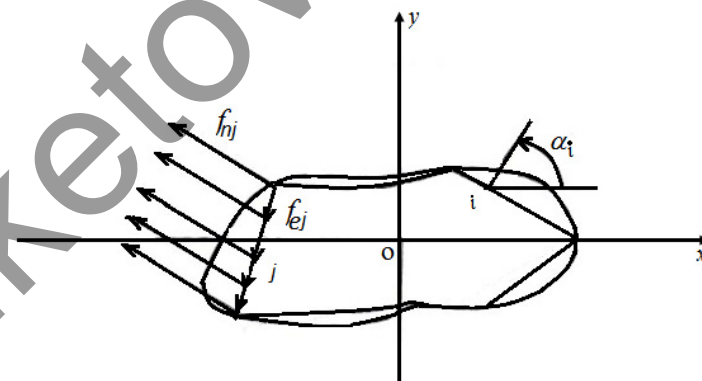

Fig. 3. Circuit approximation by broken lines, global and local coordinate systems.

Obviously, it is always possible to choose the intensity of efforts f_{ni} and f_{li} so that the vector of free terms, of system (1) will be zero. In this case $g_{nj} = g_{kj} = 0, (j = 1, 2, \dots, K)$, the stresses in the plane with the hole will not differ from the stresses in the flatness without a hole. For example, the voltage at some point in the plane is

$$\sigma_x = \sigma_x^0 + \sum_{j=1}^K (c_{xj} g_{nj} + d_{xj} g_{lj}) = \sigma_x^0 \quad (2)$$

Thus, making efforts

$$\left. \begin{aligned} f_{ni} &= -\sigma_{ni}^0 = -\frac{\sigma_x^0 + \sigma_y^0}{2} - \frac{\sigma_x^0 - \sigma_y^0}{2} \cos 2\alpha_i - \tau_{xy}^0 \sin 2\alpha_i, \\ f_{li} &= -\tau_{nli}^0 = \frac{\sigma_x^0 - \sigma_y^0}{2} \sin 2\alpha_i - \tau_{xy}^0 \cos 2\alpha_i \end{aligned} \right\}, (i = 1, 2, \dots, K) \quad (3)$$

Along the contour of the hole (see Figure 3), we achieve that the stresses in the plane loaded with “infinity” with the loaded hole do not differ from the stresses in the loaded plane without the hole. As you can see, the intensity and direction of external forces depends on the stresses in the plane without a hole and the orientation of the element (α_i - is the angle between the normal to the element directed to the region of the elastic body and the axis OX) [8-10].

Based on these considerations, we believe that the external forces acting on formulas (3) act on the elements making up the lines $BA, AA', A'B'$. On the lines CB and $C'B'$ the forces vary linearly, increasing from the nucleon (at points C and C') to the quantities characterizing the loads on the lines BA and $A'B'$. Note that expressions (3) are simplified for the hydrostatic distribution in an untouched massif ($\sigma_x^0 = \sigma_y^0, \tau_{xy}^0 = 0$). In this case $f_{li} = 0, (i = 1, 2, \dots, K)$, and external forces are determined only by the normal pressure equal σ_y^0 to the lines $BA, Aa', A'B'$, and linearly changing on the lines CB and $C'B'$.

Numerical results were obtained for three different lengths of the treatment plant ($L = 12R, L = 24R, L = 36R$). As a source for transversely isotropic sandy shale [11-13]. The angle of inclination of the plane of isotropy is $\varphi = 30^\circ$. The hydrostatic stress distribution in the pristine massif is accepted. The sizes $l = 6R, h = R$, as well as the coordinates of the point $A (X_0 = 20.8R; Y_0 = 15R)$ for all options are constant. A linear increase in external forces was carried out on the segments $CB = C'B' = 20R$, while it was set $\text{tg}\beta = 0.05$ (see figure 1). For $L = 12R$ and $L = 24R$ external forces do not reach their upper limit, but increase up to the points A and A' , which coincide in these cases with the points B and B' . When $l = 6R$ and $\text{tg}\beta = 0.05$ for $L = 12R$ on the line Aa' , these efforts are equal $0.3\sigma_y^0$, but for $L = 24R$, equal $0.9\sigma_y^0$. In figure 1 shows the locations of the feces for different $L: KK'$ for $L = 36R, SS'$ for $L = 24R, PP'$ for $L = 12R$.

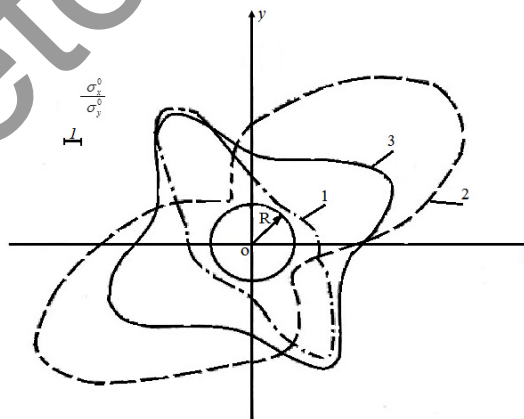

Fig.4. Plots of normal stresses on the contour of a field preparatory drift.

At $L = 12R$ (curve 1), the stresses on the circuit practically with the stresses for a single circular output, i.e. the effect of treatment work on the field drift remains insignificant. Because the face is still far enough away. The stress diagram changes significantly with $L = 24R$ (curve 2): the asymmetry of the stress distribution is visible and increase in the maximum stresses is noticeable. When $L = 36R$ (curve 3), the

maximum stresses decrease compared with the previous case and their maxima rotate approximately 90° relative to point 0.

2. Results and discussion

The calculation results indicate a significant effect of the net generation on stresses in the vicinity of the drift, the nature of the stress distribution varies depending on the distance and position of the bottom hole production, relative to the field drift, the maximum stresses on the drift circuit are achieved when the working face is located above the field drift, (at $L = 24R$).

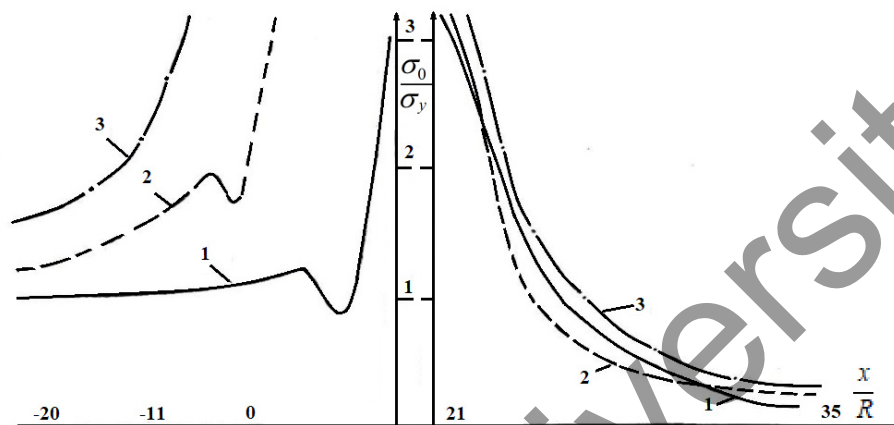

Fig. 5. Distribution of normal stresses on the lines

Figure 5 shows plots of normal stresses $\sigma_n \frac{\sigma_0}{\sigma_y}$ on the lines AE and AD for various calculation options. As we see, near the drift on the straight line AE for $L = 12R$ (curve 1) and $L = 24R$ (curve 2), the nature of the stress distribution differs from that of the straight line for $L = 36R$ (curve 3).

Conclusion

The obtained data indicate the influence of the drift on the mechanism of transfer of the support pressure before the bottom hole to the formation soil. The scheme for calculating the stress state of this mine in the dynamics of the manifestation of the support pressure on the seam takes into account the presence of heterogeneous layered soil of the coal seam, where the field drift is laid.

It contains the results of a study of the correct formulation of the problem of support pressure on an inclined-buried buried coal seam near the treatment space. It is advisable to use these methods, and it is necessary to link them with a specific system for developing coal seams and methods for preparing the mine field. Some conclusions on the choice of the location of field drifts and their content from the point of view of the "stress state" factor are recommended for implementation in mines.

Thus, the developed model of a drift embedded in a layered medium, in the zone of influence of the processing space, allows us to fully study the picture of the stress-strain state of rocks around the drift up to the processing output.

REFERENCES

- 1 Aitaliev Sh.M., Kayupov M.A. The method of boundary elements in plane problems of the concentration of elastic stresses in an anisotropic body. *In mechanics of tectonic processes*, 1983, p. 133-143. [in Russian]
- 2 Aitaliev Sh.M., Adilbekov N.A., Kayupov M.A. The investigation by the GIU method of the stressed state of a field drift during an underwork. *Izv. KazSSR, a series of physical. Math.*, 1983, No. 5, p. 78. [in Russian]
- 3 Aitaliev Sh.M., Adilbekov N.A. The solution of the elastic problem for a doubly connected anisotropic plane by the GNU method and calculation of the influence of the mine working on the field drift. *Differential equation and their applications*, 1994, pp. 96 – 105. [in Russian]
- 4 Adilbekov N.A., Shaikhova G.S., Zhurov V.V., Shegebayeva G.E. The numerical solution of one system of Fredholm integral equations of the third kind in the problem of support pressure near the mine. *Science News of Kazakhstan*, 2019, No. 3, pp. 98 – 105.

5 Issagulov A.Z , Belomestny D., Shaikhova G.S., et al. Functions of atoms radial distribution and pair potential of some semiconductors melts. *The Bulletin of the National Academy of Sciences of the Republic of Kazakhstan*, 2019, Vol. 4, No.380, pp.6-14. doi:10.32014/2019.2518-1467.86

6 Kavlakan M.V., Mikhailov A. M. On the distribution of pressure on the formation when the horizontal development. *Physical and technical problems of mineral development, Kazakhstan*, 1977, No. 5, pp. 48-53.

7 Kavlakan M.V. About one method of solving spatial problems about the reference pressure. *Physical and technical problems of mining*, 1981, No. 6, p. 17-27.

8 Shaikhova G.S. Explanation of the Cluster Structures Melting Mechanism And their influence on the molten state's physical and chemical nature. *Complex Use of Mineral Resources*, 2021, No.1(313), pp. 62 – 68. doi:10.31643/2021/6445.08

9 Suleimenov N.V, Shapalov Sh.K, Khodzhaev R.R, Shaikhova G.S. Computerized Analytical System for Assessing Fire and Environmental Safety of Mines in the Karaganda Coal Basin. *Intern. Journal of Engineering Research and Technology*, 2020, Vol.13, No. 6, pp. 1133-1136.

10 Akhmetov K.M., Shaikhova G.S, Zhurov V.V., et al Mathematical model of coal self-heating in a stack. *Complex Use of Mineral Resources*, 2021, No.3 (313), pp. 90 - 96. <https://doi.org/10.31643/2021/6445.32>

11 Kazhikenova S.Sh., Shaltakov S.N., Belomestny D., Shaikhova G.S. Finite difference method implementation for Numerical integration hydrodynamic equations melts. *Eurasian Physical Technical Journal*, 2020, Vol. 17, No.1(33), pp. 50 – 56. doi: 10.31489/2020No1/145-150

12 Bayer C., Belomestny D., Redmann M., Riedel S., Schoenmakers J. Solving linear parabolic rough partial differential equations. *Journal of Mathematical Analysis and Applications*, 2020, No. 490(1), pp. 124236. doi:10.48550/arXiv.1803.09488

13 Belomestny D., Schoenmakers J. *Multilevel Methods*. Palgrave Macmillan, London, 2018, Vol. 19, No.1(31), pp. 55-75.