

UDC 533.6.01; 621.548

## THE DEVELOPMENT OF A DOUBLE WIND TURBINE WITH SAIL WIND WHEELS PLACED AT RIGHT ANGLE TO ONE ANOTHER

Kussaiynov K.K., Sakipova S.E., Kambarova Zh.T., Turgunov M.M.

*To address the problem of increasing the operation efficiency of the wind turbine with dynamically changeable shape of blades when there is no constant wind direction, in work double wind turbines placed perpendicular to each other was studied. In this case, the entire working "circle" of wind directions is completely covered by two wind turbines. The total contribution of each wind turbine at all directions of the wind gives a permanent result of generated power. The results of the test model of the double wind turbine to determine the aerodynamic characteristics.*

**Keywords:** double wind turbine, sail wind wheel, renewable energy sources, aerodynamic characteristics, thrust force.

### Introduction

Currently, one of the priority directions of development of electric power industry and solving environmental problems in Kazakhstan is the use of renewable energy sources and implementation of energy saving and resource conservation programs. The Message of the President of the Republic of Kazakhstan, the Leader of the Nation N.A. Nazarbayev to the people of Kazakhstan of December 14, 2012 "Strategy "Kazakhstan-2050": a new policy line of the established state", states the need to develop alternative forms of energy production, and active introduction of technologies using solar and wind energy. The potential of renewable energy resources (hydro-, wind and solar energy) in Kazakhstan is very significant. But despite this, the share of alternative energy generation in Kazakhstan is only 0.4% of the total quantity [1].

In this regard, the establishment of wind power plants operating efficiently at low annual average wind speed is very topical for Kazakhstan. It is consistent with the priorities of development of science in the country. At the present stage of development of science in our country, this problem is urgent in connection with the preparation of Kazakhstan to the World Exhibition of Science and Technology «EXPO-2017". The main thematic areas of «EXPO-2017" are the concepts of "Energy of the Future" and "Ecologically clean energy".

### Problem statement

In actual practice, the developed in works [2, 3] wind turbine with a dynamically changeable blade shape is set to the wind rose in the prevailing direction of the local wind. The wind turbine can operate effectively at the rake angle change of the direct wind flow within the range  $-45^{\circ} \div +45^{\circ}$  and the reverse wind flow  $-135^{\circ} \div +135^{\circ}$ , i.e. half of the "circle" of all kinds of wind directions "is covered" by one wind turbine. In areas where there is no constant direction of the wind rose, where the wind direction changes around the "circle", the efficiency of the wind turbine falls; the problem calls for solution at later stages of the work.

To address the problem of increasing the operation efficiency of the wind turbine with dynamically changeable shape of blades when there is no constant wind direction, the authors studied double wind turbines placed perpendicular to each other. In this case, the entire working "circle" of wind directions is completely covered by two wind turbines. The total contribution of each wind turbine at all directions of the wind gives a permanent result of generated power.

The experimenters made a model of a double wind turbine with sail wind wheels, placed at a right angle to each other. The experimental model of the double wind turbine consists of two wind wheels made of metallic frame bars; each wind wheel comprises six triangular sail blades made of

light and durable material, one end of which is fixed to the top of the frame by a sturdy yarn; of support bars and a bearing. The model is fixed to the mount by support bars. Fig. 1 shows an overview of the wind wheel. The wind wheel includes six sail blades, frame rods and adjustable flexible fastening of the movable end of the blade made of a sturdy yarn. Fig. 2 shows a lateral-side view of a single wind turbine. The wind turbine consists of a shaft (1), support bars (2), support bar fasteners (3), a wind turbine rotation disc (4), a bearing (5), the frame bars (6), a sheave (7), sail blades (8). The wind wheel is made of six blades, the mid-section of the sail blades looks like a triangle. The blown surface equals to a circle area, which is equal to a double diagonal of the surface of the blade middle section.

Fig.3 shows the arrangement of the sail windwheels of the double wind turbine relative to one another on the support. The angle between the two sail windwheels is a right one (90 deg.)

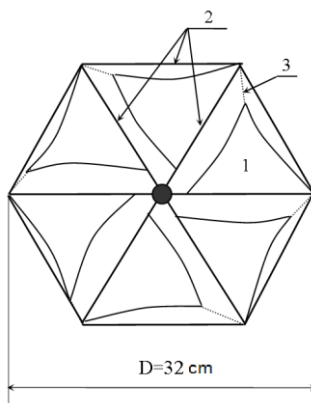

1 – a wind turbine blade with dynamically variable shape, 2 – frame, 3 – adjustable flexible fastening of the movable blade tip made of sturdy yarn

Fig.1. A wind wheel with six sail blades

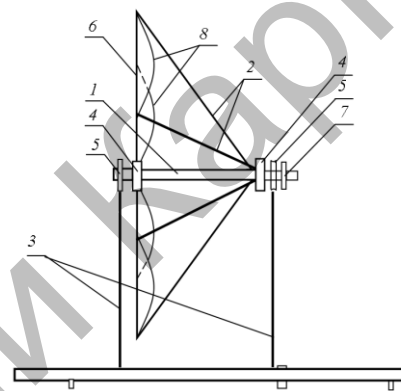

1 – shaft, 2 – support bars 3 – fasteners of support bars 4 – a wind turbine rotation disc, 5 – a bearing, 6 – frame bars, 7 – a sheave, 8 – sail blades

Fig.2. The model of a single wind turbine with sail blades

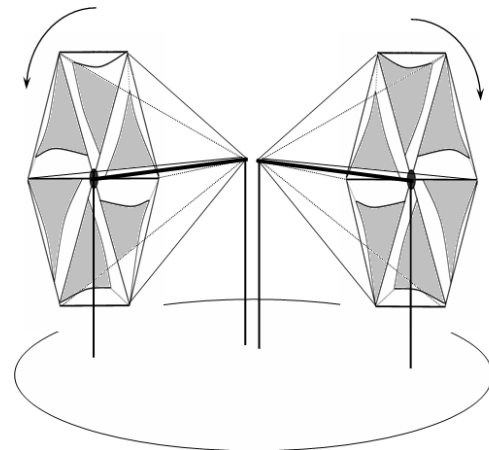
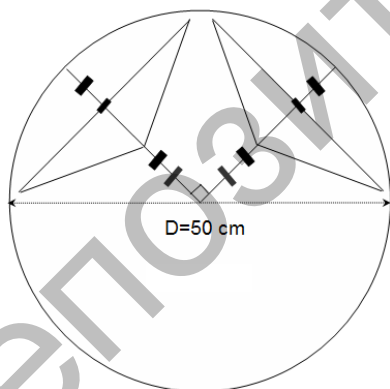

Fig.3. Arrangement of sail windwheels of the double wind turbine, relative to each other on the support: (a) a top view, (b) a front view

The wind turbine with a sail wind wheel operates as follows: the wind flow blows on the windwheel consisting of sail blades (8). When the wind blows on the sail blades, there aerodynamic forces arise, which through the bars (6) and (2) are transmitted to the wind turbine shaft, producing a torque at the latter. The emerging force is the thrust force transforming the wind energy into rotational motion of the wind turbine. The reverse of the wind does not change the direction of rotation of the wind turbine axis to the opposite one.

Exposed to straight wind flow and radial flow at rotary motion, the wind turbine has optimum aerodynamic characteristics due to the self-regulating shape of the blade surfaces. In a wind stream, the wind turbine is a self-organized unit, effectively converting the wind energy into the energy of rotational motion. The flexible design ensures minimal aerodynamic drag and leads to increased wind use efficiency. In a wide range of wind direction variations, the wind turbine remains in operation.

It is possible to maintain uniform wind turbine speed when the wind speed changes by varying the length of the fastening yarns of the movable blade tips depending on the wind speed. The bulk of the plant is concentrated in the wind turbine; this fact partially neutralizes the torsionals at rushes of wind. The load-bearing frame of the wind turbine ensures its stable operation in a non-uniform air flow, it makes possible to improve the strength and reliability of the design at high wind speeds.

The wind turbine is equipped with blades having a considerable sail surface that provides the aggregate capacity proportional to the size of the wind wheel. The advantage of the designed wind turbine is that the design does not require a reversal of the wind turbine when the direction of a wind flow changes.

In the case of operation of the double wind turbine with two sail wind wheels placed at a right angle to each other, the whole operating "circle" of the wind directions is completely covered by two wind turbines ( $-180^{\circ} \div +180^{\circ}$ ). One wind turbine will cover half of the "circle" of all possible wind directions, i.e. will efficiently convert the wind energy at a rake angle of a straight flowing wind  $-45^{\circ} \div +45^{\circ}$  and a back flowing wind  $-135^{\circ} \div +135^{\circ}$ ; and arranged vertical to it, the second turbine will cover the remaining half of the circle of all possible wind directions, i.e. it will operate effectively at the angle rake of the straight flowing wind flow from  $-135^{\circ} \div -45^{\circ}$  and  $+45^{\circ} \div +135^{\circ}$ .

Fig.4 shows a reduced model of a double wind turbine on the basis of two wind wheels placed vertically to each other with sail blades. The diameter of each wind wheel is 32 cm.



Fig.4. The overview of the reduced model of a double wind turbine in the operation area of a wind tunnel

### Test results

The double wind turbine model with sail wind wheels placed at right angles to each other was tested in a laboratory in order to determine its aerodynamic characteristics. The experimenters studied dependences of the thrust force of the model of the double wind turbine with sail wind wheels placed at right angles to each other on the rate and direction of the air flow.

Fig. 5 a) and b) show dependences of the thrust force of the wind turbine 1 and 2 on the direction of air flow at a constant rate 7 m/s. The shaded area indicates the effective operating area of wind turbines 1 and 2.

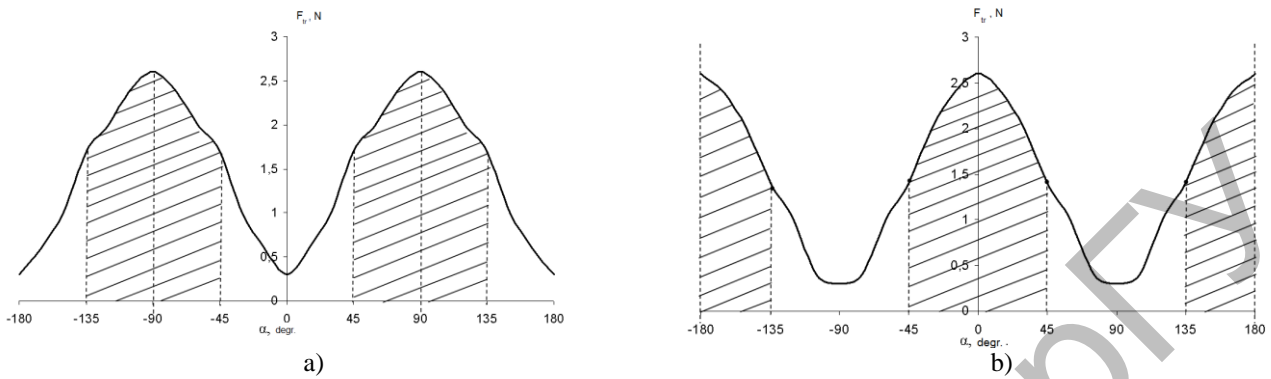

Fig.5. Dependences of the thrust force of the wind turbines 1 and 2 on the direction of air flow at a constant flow rate 7 m/s

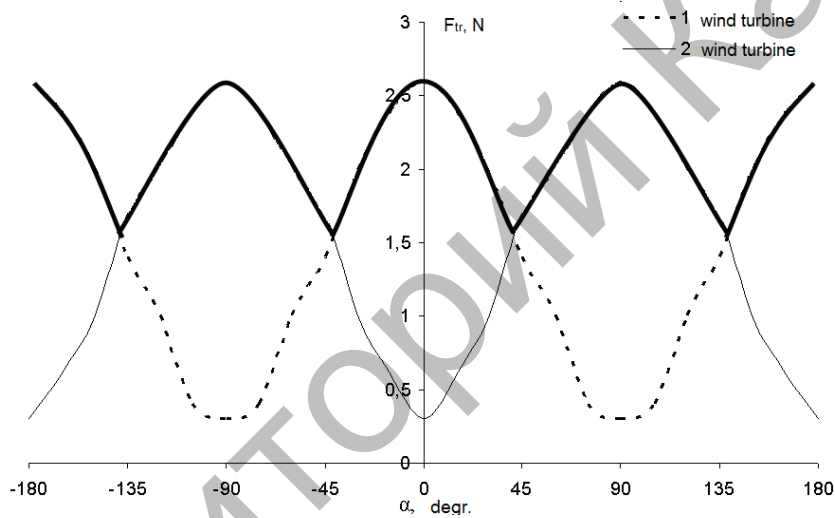

Fig. 6. Dependence of the thrust force of the double wind turbine at a constant air flow rate 7 m/s

Fig.7 presents a graph of thrust force dependences of the double wind turbine on the flow rate at different angles of attack of airflow. The thrust force was determined by the weighting method.

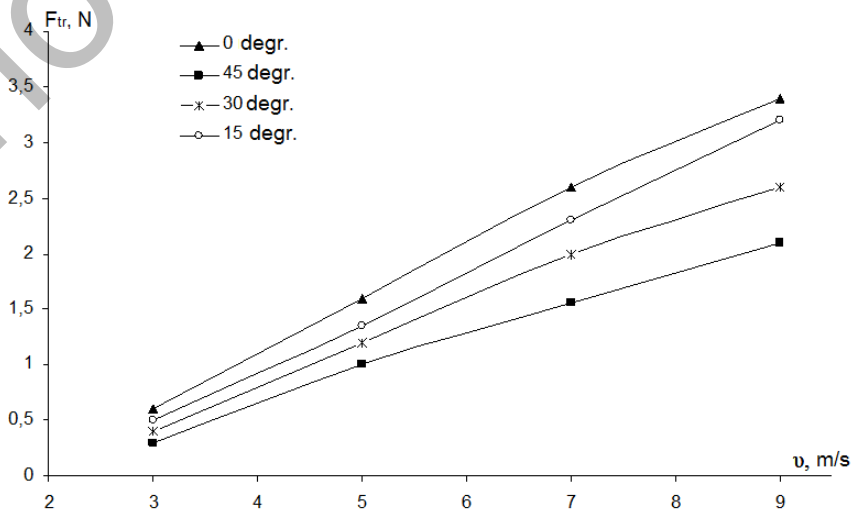

Fig.7. Dependence of the thrust force of the double wind turbine on the flow rate at different angles of attack of airflow

As seen in Fig. 7, when airflow rate grows, an increase in the trust force of the double wind turbine is observed. At the straight air flow direction (angle of attack  $\alpha = \pm 0^\circ$  or  $\pm 90^\circ$ ), the thrust force reaches its maximum at 9 m/s.

Fig.8 shows the graph of dependences of the thrust moment on the air flow rate at various angles of attack. Fig. 9 shows a graph of dependences of thrust coefficient  $C_M$  of the double wind turbine on the Reynolds number  $Re$  at different angles of attack of the air flow. This graph shows that the thrust coefficient of the double wind turbine does not depend much on the Reynolds number variations. Qualitative characteristics of the dependences on the Reynolds number for different angles of attack of the air flow are essentially the same.

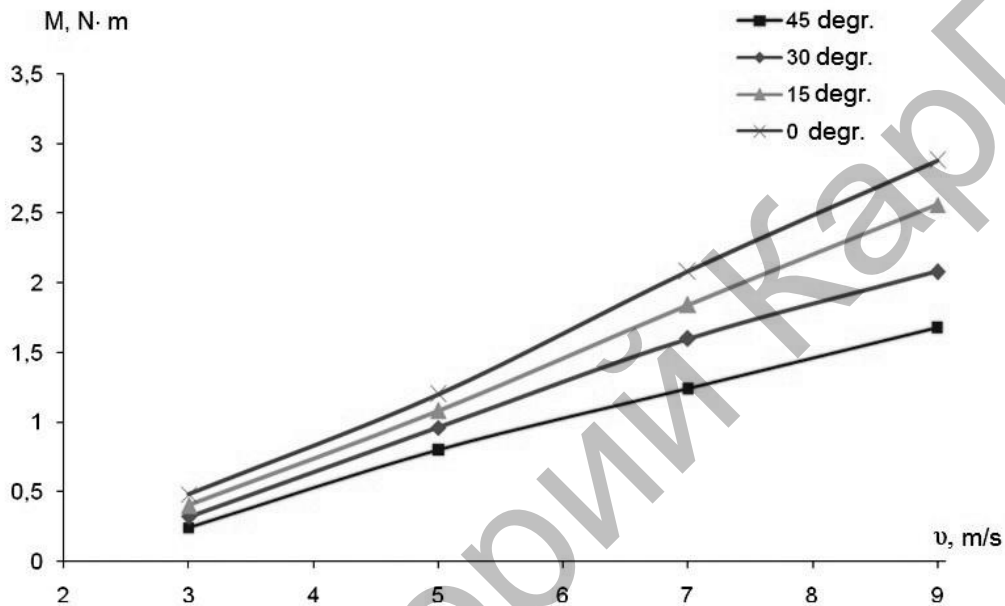

Fig.8. Graph of dependences of the thrust moment on the air flow rate at various angles of attack

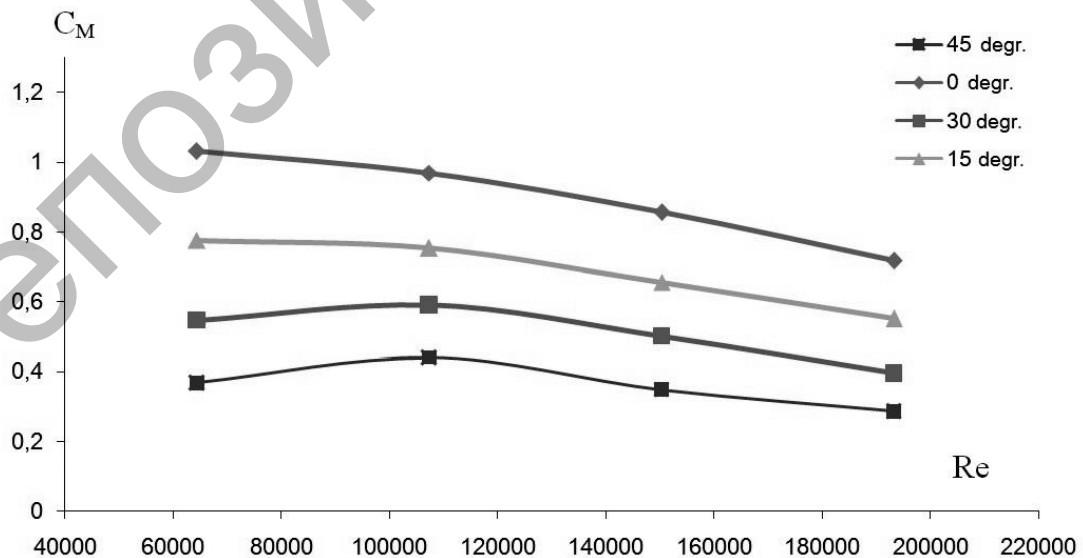

Fig. 9. The dependence of the thrust coefficient of the double wind turbine on the Reynolds number at different angles of attack of the air flow

Fig. 10 shows a graph of dependences of thrust coefficient of the wind turbine on the angle of attack at different rates of airflow. At a constant air flow rate, the value of thrust coefficient decreases when angle of attack changes. This is due to the decrease in the area of the mid-section of the wind wheel.

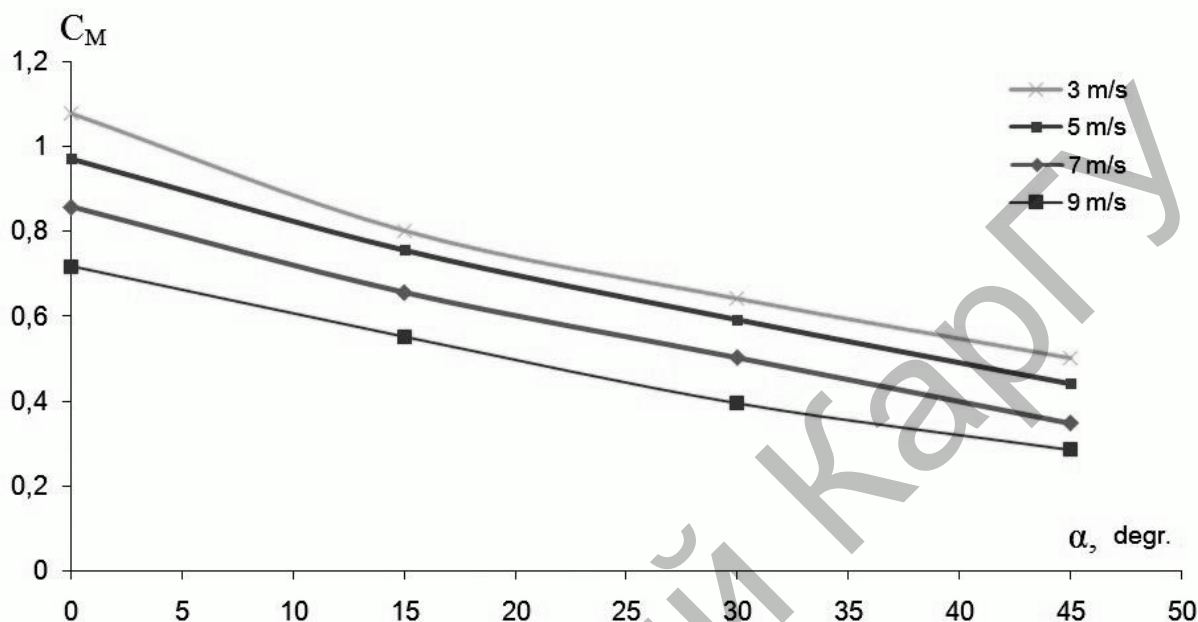

Fig.10. The dependence of the thrust coefficient of the wind turbine on the angle of attack of the air flow at different rates of the airflow

## Conclusion

As a result of the experiments, dependences of aerodynamic thrust force, and of thrust moment on the rate and angle of attack of the air flow were obtained. The establishment of dependences of dimensionless aerodynamic parameters on similarity criteria, in this case, the Reynolds number, made it possible to obtain universal dependences, which can be used to produce a real operating plant.

## REFERENCES

1. Mukasheva A.A., Sharapatova G.S. Problems of the use of renewable energy sources in the Republic of Kazakhstan (in the framework of EXPO 2017). *Evrasiiskii yuridicheskii zhurnal* (in Russian), 2013, No.4(59), pp. 96-99.
2. Kussaiynov K., Sakipova S., Kambarova Zh., Kussaiynova A., Alibekova A. Development of a sail type wind turbine with dynamic varying shape surface blades. *Proceedings of Eleventh International Conference on Flow Dynamics* (October 8 - 10, 2014), Sendai International Center Sendai, Japan, 2014, pp.194-195.
3. Sakipova S.E., Jakovics A., Kambarova Zh.T. et al. Development a sail type wind turbine for autonomous energy supply according climate conditions. *Eurasian Physical Technical Journal*, 2014, V.11, No.2 (22), pp.11-19.