

PAPER • OPEN ACCESS

Plasmon-enhanced stimulated emission of chromene dye

To cite this article: E V Seliverstova and N Kh Ibrayev 2016 *J. Phys.: Conf. Ser.* **735** 012018

View the [article online](#) for updates and enhancements.

Related content

- [Synthesis of \(iso\)quinoline, \(iso\)coumarin and \(iso\)chromene derivatives from acetylene compounds](#)
D S Ryabukhin and A V Vasilyev
- [Focus on multidimensional optical spectroscopy and imaging](#)
Steven T Cundiff and Harald F Kauffmann
- [Magnetic tuning of upconversion luminescence in Au/NaGdF₄:Yb³⁺/Er³⁺ nanocomposite](#)
Gangtao Dai, Zhiqiang Zhong, Xiaofeng Wu et al.

Репозиторий КарНУ

Plasmon-enhanced stimulated emission of chromene dye

E V Seliverstova¹ and N Kh Ibrayev

Institute of Molecular Nanophotonics, Y.A. Buketov Karaganda State University,
100028 Universitetskaya str. 28, Karaganda, Kazakhstan

Abstract. Effect of silver nanoparticles on spontaneous and stimulated emission of chromene-3 in ethanol solution is studied. It is established, that upon laser photoexcitation of solution the spontaneous fluorescence is observed, which with increasing of pumping energy transforms in stimulated emission. The increasing of fluorescence, stimulated emission and lasing threshold was observed upon addition of silver nanoparticles. The dependence of intensity of lasing of silver concentration correlates with data of fluorescence.

Introduction

During the last years the great progress was made in the field of solid-state active tunable lasers based on organic compounds. The yellow-green spectral range (550-590 nm) is most mastered¹. Blue and red spectrum is less filled with active media, but research for their development are carried out actively^{2,3}. Development of solid active media, emitting in the red region of the spectrum (over of 600 nm) is important in connection with the decision of a number of biological problems, since this radiation can penetrate deeply into biological tissue. The emission spectrum of such a range is used in photodynamic therapy of cancer.

Recently the studies of excitation of localized plasmon resonance of metal nanoparticles are performs actively^{4,5}. Among the optical manifestations of localized plasmon resonance of nanoparticles (NPs) metals most famous is enhanced Raman scattering⁶. Molecules of luminophores placed near the surface of metal NPs undergo to effect of local electromagnetic fields. Thus, depending on the distance between the NPs and the molecule, the emission intensity of fluorophores is enhanced or quenched⁷. At short distances and direct contact of dyes and NPs the luminescence is quenched due to the prevalence of nonradiative energy transfer from the fluorescent molecules to NPs.

From a practical point of view, the interest in plasmonic effect is associated with the ability to create highly fluorescent sensors⁸, optoelectronic devices⁹, nanolasers¹⁰ and others. One of the promising areas of modern laser physics is development and the study of composite media based on the laser-active molecules and metal nanoclusters. There is evidence that the addition of metal NPs in the active medium of dye lasers leads to a decrease in the lasing threshold¹¹⁻¹⁴.

Here the results of plasmon effect on photonics of Chromene-3 dye are presented. These dye is the derivatives of the lasing dye Coumarine-7. The structure of dye is shown on figure 1.

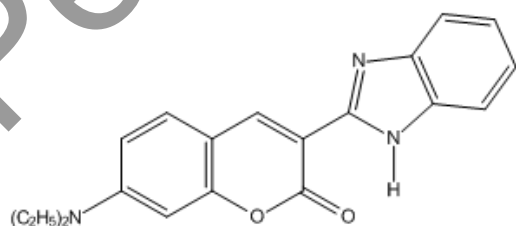

Figure 1. Structure formulae of Chromene-3, R= NH.

2. Experiment

¹ E-mail: genia_sv@mail.ru

Spectral and luminescent features of dye were studied in ethanol solutions. Concentration of dye in solution was equal to 10^{-4} mol/l for Chromene-3. Ag NPs were prepared by ablation of metallic silver in ethanol. The size of Ag nanoparticles in colloidal solutions was determined by dynamic light scattering analyzer of the sizes of submicron particles Zetasizer Nano ZS (Malvern). The average size of the silver particles was equal to 90 nm. The spread of the values of dispersibility of the silver particles was minimal and ranges from 10 to 20 nm.

Fluorescence spectra was measured with spectrofluorimeter Cary Eclipse (Agilent). The fluorescence decay kinetics of dye was measured using a pulsed spectrofluorometer with picosecond resolution and registration of the time-correlated photon counting mode (Becker & Hickl). Fluorescence excitation of samples was performed using a pulsed laser with $\lambda_{\text{gen}} = 488$ nm and a pulse width at half-maximum $\tau = 40$ ps.

Absolute quantum yield of dye was measured in reflectometric sphere AvaSphere-50-REFL (Avantes BV) and was equal to 0.99 for Chromene-3. Measurements of the spectral and energy characteristics of induced emission of solutions of chromene-3 were performed upon excitation of samples by second harmonic of Nd:YAG laser (SOLAR LQ 215, $\lambda_{\text{gen}} = 532$ nm, $E_{\text{imp}} = 90$ mJ, $\tau = 10$ ns) in the cross-version¹⁴ (figure 2).

Pump power density was varied with the help of neutral density filter and was 0.005-0.2 MW/cm². Stimulated emission with the help of converging lens focused on the input of optical fiber spectrometer AvaSpec-2048.

An optical resonator, which was formed by reflection mirror (6) and the front edge of the cell with a dye solution (7) were used at the measuring of the lasing properties. Pump radiation passing diaphragm (3) by the cylindrical lenses (4,5) was focused on the lateral face of the cell in the strip with area of 0.07 cm². Generation of radiation arises in a narrow region near the wall of the front wall of the cell.

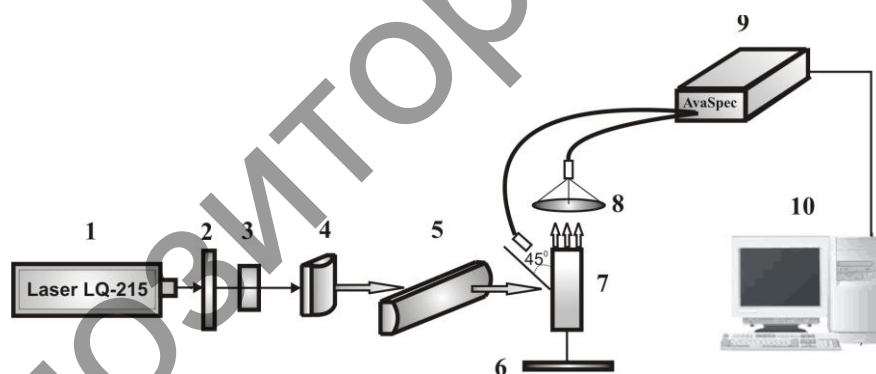

Figure 2. Scheme of apparatus for the study of the lasing characteristics of molecular systems: 1 – laser LQ 215; 2 – neutral density filters; 3 – aperture; 4,5 – cylindrical lens; 6 – nontransmitting mirror; 7 – the sample; 8 – converging lens; 9 – AvaSpec-2048 spectrometer; 10 – computer.

Pump power density was varied with the help of neutral density filter (2) and was 0.005-0.2 MW/cm². Stimulated emission with the help of converging lens (7) focused on the input of optical fiber spectrometer AvaSpec-2048. The lasing spectra were measured on spectrometer AvaSpec-2048 (8) connected to the computer (9). Relative error in the determination of the spectral characteristics was 3%.

3. Results and discussion

Absorption spectra of silver NPs and Chromene-3 are shown on the figure 3. It is seen that absorption spectrum of silver NPs exhibits the maximum at 452 nm. Absorption bands of Ag NPs and dye is overlapped, It is evidence that conditions of plasmonic resonance are stratified. Long-wavelength

absorption spectra of ethanol solution of dye is observed as wide band in the region of 450-600 nm with two evident maxima at 517 and 550 nm. Fluorescence spectra of Chromene-3 exhibits the maximum at 580 nm and weak pronounced shoulder in the range of 615-620 nm. The position and shape of fluorescence spectra is independent of excitation wavelength. Spectral parameters of dye solution are shown in the Table 1.

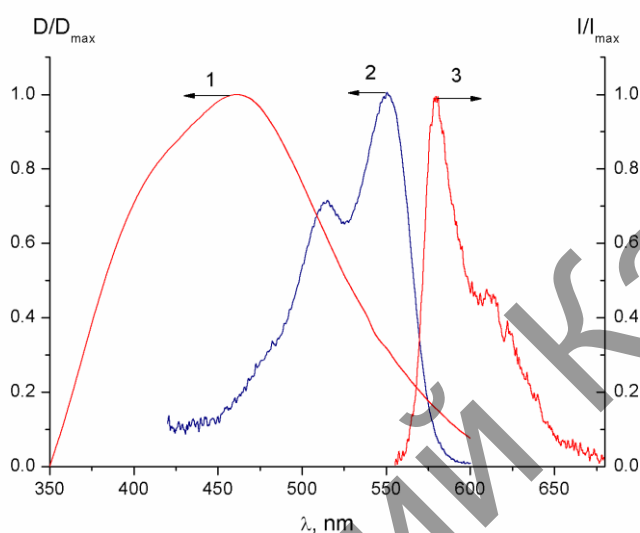

Figure 3. Absorption (1,2) and fluorescence (3) spectra of Ag NPs (1) and Chromene-3 in ethanol (2,3), $C_{\text{dye}}=10^{-4}$ mol/l.

Table 1. Spectral parameters of Chromene-3 at various concentrations of Ag.

$C_{\text{Ag}}, \text{ mol/l}$	$\lambda_{\text{abs}}, \text{ nm}$	$\Delta\lambda_{1/2}^{\text{ab}}, \text{ nm}$	D	$\lambda_{\text{fl}}, \text{ nm}$	$\Delta\lambda_{1/2}^{\text{fl}}, \text{ nm}$	$I_{\text{fl}}, \text{ a.u.}$	$\tau_{\text{fl}}, \text{ ns}$
0	550	68	0.45	580	27	7.7	4.1
$6 \cdot 10^{-6}$	550	68	0.48	580	27	7.6	4.1
$8 \cdot 10^{-6}$	550	68	0.52	580	27	8.0	4.1
10^{-5}	550	68	0.54	580	27	8.6	4.1
$2 \cdot 10^{-5}$	550	68	0.53	580	27	8.55	4.1
$4 \cdot 10^{-5}$	550	68	0.52	580	27	8.5	4.1
$6 \cdot 10^{-5}$	550	68	0.50	580	27	8.0	4.1

It is evidence that absorbance of dye molecules increases approximately on 20% with the growth of concentration of Ag NPs (figure 4). Maxima of absorption coefficient is observed for $C_{\text{Ag}}=10^{-5}$ mol/l. Optical density decreases with further increase in the concentration of NPs. Fluorescence intensity behaves similarly. The fluorescence lifetime is not changed.

Spectra of stimulated emission of ethanol solution of Chromene-3 at different densities of the pump power are shown on the figure 4.

It is seen, that upon excitation of dye with $P=0.08 \text{ MW/cm}^2$ Chromene-3 starts to generate the stimulated emission. Maximum of spectra of stimulated emission coincides with the maximum of fluorescence spectra. The intercity of emission at mentioned pump power density increases in 6.2 times, and the half-width of emission increases of 27 to 5 nm.

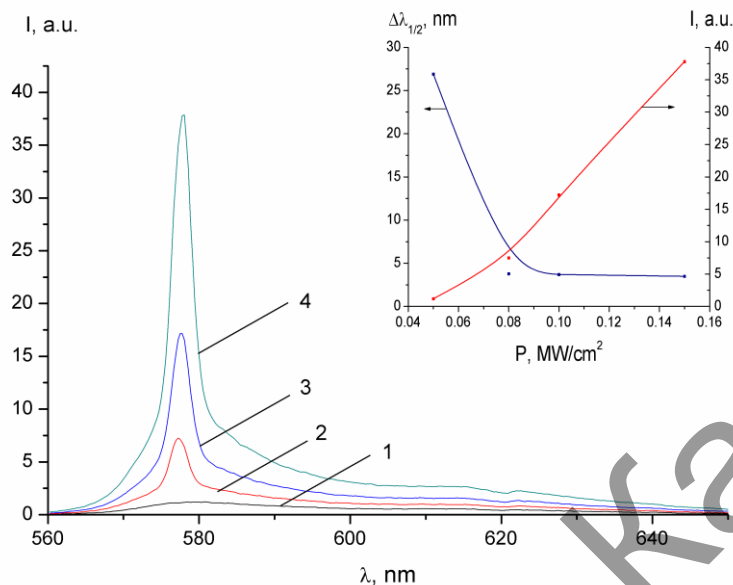

Figure 4. Emission spectra of Chromene-3 solution at various pump power densities, MW/cm²: 1 – 0,05; 2 – 0,08; 3 – 0,1; 4 – 0,15. In the inset – dependence of the intensity and half-width of spectrum of lasing of Chromene-3 via pump power densities.

Properties of stimulated emission of dye are also dependent on the concentration of silver NPs (Table 2). Obtained dependence concerning that the lasing threshold at $C_{Ag}=10^{-5}$ mol/l decreases.

Table 2. Influence of An NPs on the lasing properties of Chromene-3

C_{Ag} , mol/l	λ_{las} , nm	$\Delta\lambda_{1/2}^{las}$, nm (P=0.05 MW/cm ²)	I_{las} , a.u.
0	580	27	12
$6 \cdot 10^{-6}$	580	26	13.5
$8 \cdot 10^{-6}$	58	22	17.5
10^{-5}	580	13	24
$2 \cdot 10^{-5}$	580	16	20.1
$4 \cdot 10^{-5}$	580	20	15.9
$6 \cdot 10^{-5}$	580	24	12

In the figure 5 it is shown that addition of silver NPs in dye solution leads to the increasing of intensity of emission of Chromene-3 by 2 times, and the half-width also changed in 2 times. The furthering growth in concentration leads to increasing both of intensity and half-width of band of stimulated emission of dye.

4. Conclusion

The spectral-luminescent and lasing properties of chromene dye were studied. Compounds emit light in the red range of the spectrum and could be withdrawn in biology and medicine.

Studies have shown that the addition of silver NPs in dyes ethanol solutions leads to enhancing of fluorescence intensity. The maximum of intensity of emission of Chromene-3 observed at a concentration of Ag NPs equal to 10^{-5} mol/l. A further increase in the number of NPs leads to quenching of luminescence. The life times of fluorescence for both dyes does not change with the addition of silver NP in solution.

Upon excitation of ethanol solutions of dyes by second harmonic Nd:YAG laser, the lasing of dyes was observed. For Chromene-3 lasing threshold observed when the pump source power density equal

to $P = 0.08 \text{ MW/cm}^2$. When the Ag NPs were added to the dye solutions increase in intensity and narrowing of the band of stimulated emission was observed. The lasing threshold was also reduced.

5. Acknowledgments

The authors thanks Zeynidenov A.K. and Aymukhanov A.K. for the help in the study of the properties of stimulated emission

References

- [1] Garcia-Moreno I. and Costela A. 2009 *Adv. Funct. Mat.* **19(16)** 2547
- [2] Xiao Y and Zhang D 2011 *Commun.* **47** 11513
- [3] Shimizu S and Lino T 2013 *Commun.* **49** 1621
- [4] Klimov V V 2009 *Nanoplasmonics* (Moscow: Fizmatlit) p 480
- [5] Maier S A 2007 *Plasmonics: Fundamentals and Applications* (Berlin/Heidelberg: Springer) p 248
- [6] Tian Z.Q. 2005 *J. Ram. Spect.* **36(6-7)** 466
- [7] Lakowicz J.R. 2003 *Analyt. Biochem.* **320(1)**
- [8] Homola J, Yee S S and Gauglitz G 1999 *Sens. Actuators B Chem.* **54(1-2)** 3
- [9] Novotny L 2006 *Principles of nano-optics* (Cambridge: Cambridge University Press) p 539
- [10] Oulton R F and Sorger V J 2009 *Nature* **461** 629
- [11] Vasa P et al 2008 *Phys Rev Lett.* **101** 116801
- [12] Kim W, Safonov V P, Shalaev V M and Armstrong R L 2009 *Phys. Rev. Lett.* **82(24)** 4811
- [13] Ibrayev N Kh and Zeinidenov A K 2011 *Laser Phys. Lett.* **11(11)** 115805
- [14] Ibrayev N Kh, Zeinidenov A K and Aimukhanov A K 2014 *Optics and Spectr.* **117(4)** 540