

MOBILE PREMISES HEATING SYSTEM

Bedych T.V.¹, Shayakhmetov A.B.^{1*}, Omarov M.S.¹, Isintaev T.I.²

¹Kostanay Engineering and Economic University named after M. Dulatov, Kostanay, Kazakhstan, shayahmetov0501@mail.ru

²Kostanay Regional University named after A. Baitursynov, Kostanay, Kazakhstan

In production and in everyday life, various heating systems are used. Alternative heating methods have also been used in recent years. One of the sources for the heating system is the Sun. The use of solar energy is of great importance for objects cut off from centralized heat and power supply systems: small villages and auls, farm formations, distant pasture breeding, mobile houses. Heating from the sun, created on the basis of solar panels, is carried out by installing an electric heater. Currently, more and more attention of consumers is drawn to the electrically conductive carbon-based fuel material (carbon). The aim of the study was to study the use of an alternative energy source in the form of solar radiation and carbon thermal flexible material as a heater for heating mobile living quarters of farmers. To carry out the research, a solar station and a heater with a carbon fiber heat-emitting flexible material were installed on the farmer's mobile house. Studies have shown that the proposed system is efficient and in comparison with other systems, such as solar collectors, the system has a number of advantages.

Keywords: heating, heat supply, sun, fuel, energy, solar panel, carbon, carbon-based fuel material, premises.

Introduction

Analysis of energy savings in traditional residential architecture points to the inadequacy of the use of solar energy resources in different climatic conditions. This refers to the orientation of buildings relative to the cardinal points, as well as relative to the prevailing wind direction. Real urban planning has traditionally tended to locate buildings arbitrarily or according to the relief of the terrain (along highways, riverbanks, extended folds of terrain, etc.) [1, 2]. Another problem related to the energy saving of buildings is the minimization of heat loss through the construction of buildings. The decisive role in this case belongs to the standards for the thermal resistance of enclosing structures. A research was conducted on the modernization of the villa, using a combination of passive and active measures to improve thermal comfort. The walls and ceilings were insulated, three solar air collectors were turned on, and two pellet stoves were installed. The results of the thermal comfort showed a 66% savings on heating [3].

In particular, when designing houses, it is recommended to be guided by the following:

- consider the energy savings of the whole building (due to thermal insulation);
- there must be a guarantee of economic efficiency of the system and its environmental friendliness in operating modes;
- ensure the use of advanced engineering solutions in the design that will ensure the efficient operation of inexpensive systems.

1. Object of study and experimental technique

Various heating systems are applied in production and in household use. Also in recent years, alternative methods of heating have been used. One of the most powerful and inexhaustible sources is the Sun, which daily supplies a huge amount of kilowatts of free energy. Solar energy is always available, although it depends on the weather conditions or time of the day. Solar heating provides a lot of opportunities and advantages [4]. The use of solar energy is most feasible for facilities that are disconnected from centralized heat and power supply systems: villages, farms, distant pastures, mobile homes. The basis of the project is the practical application of the results of the house energy balance calculation [5].

Considering the various schemes for solar heat supply, and their elements, it is revealed that:

- it's application in the north-east of Kazakhstan, direct solar water heating must be used as a supplementary to the traditional "spring-summer-autumn" mode;

- flat collectors are not recommended for use in cold regions of Kazakhstan;
- for the north-east of Kazakhstan it is possible to use systems with direct solar heating

Systems for creating indoor comfort using solar energy can be divided into different schemes. The intermediaries between the solar rays and the energy generating mechanism are solar panels or collectors, which differ both in purpose and design [6]. Batteries accumulate energy from the sun; and they represent panels with photovoltaic cells on one side and a locking mechanism on the other. Photovoltaic batteries assembled from monocrystalline cells are considered the most suitable option for the installation of autonomous heating systems in northern regions. The sun rays that reach the Earth's surface are divided into two types: direct and scattered [7].

The sun reaches a lower angle in winter than in summer, so the solar modules must be positioned at a higher angle in winter than in summer. This allows them to work more efficiently and allows the solar modules to absorb reflected sunlight from the snow. By positioning the solar modules at a higher angle, you also partially solve the problem of accumulated snow on the panels. In many cases, it will simply not linger on the solar module. The opposite situation with the angle of inclination occurs in the summer. The smaller the angle, the better, of course the optimum angles depend on the geographical location. If there is no possibility of changing the angle twice a year (summer/winter), it is better to fix the modules at the optimum angle, the value of which is an average value between the optimum summer and winter angle. Each latitude has its own optimum angle of inclination for the solar modules. Each latitude has its own optimal tilt angle for solar modules. For spring and autumn, the best slope angle is equal to the latitude value of the terrain. In winter, 10-15 degrees are added to this value, and in summer they are taken away. That is why we usually recommend adjusting the inclination angle twice a year, summer/winter. Small deviations of up to 5 degrees from the optimum values do not significantly affect generation efficiency. The most common way to mount solar panels on the roof of a house is at a 45 degree angle.

If you have a summer/winter tilt system installed, you get an increase in generated electricity of around 10-12%, which is quite high. This is especially important in winter. Solar heating, based on solar panels, is achieved by installing an electric heater. The photovoltaic cells only provide power to the heating elements installed in the electric heater, not directly related to the heating circuit [4].

The disadvantages of heating elements include high metal consumption and cost due to the use of expensive materials (nichrome, stainless steel), not very long service life, the inability to repair when the spiral burns out [8]. To obtain composite materials suitable for use in solar water heaters without tanks, expanded graphite with different mass fractions is used [9]. Currently, more and more attention of consumers is drawn to the electrically conductive carbon-based fuel material (carbon). Carbon includes all composite materials in which the carrier base is carbon fibers. Carbon fiber reinforced plastic (carbon) has unique performance properties, which are provided by a combination of various materials - carbon cloth and epoxies. Heating elements made of such material work on the principle of "infrared heating": infrared radiation, which bypasses the air gap relatively unobstructed, first heats up interior objects, walls, floors, people, animals, etc. in the room; these heated objects then give off the heat to the surrounding atmosphere. Carbon material is one of the innovative options for maintaining a comfortable temperature in heated rooms and has unique performance characteristics [10, 11].

Therefore, an innovative carbon fiber flexible material is proposed for use as a heating device, and is a thermo-film (heating mesh) made of interlaced longitudinal and transverse carbon fibers, which are covered with an electrically insulating material for safety purposes. The heat source in the mesh is a heating carbon filament with a conductive layer without the use of metal. The heating elements are laminated on both sides in special electro technical polyester that provides full water resistance and high protection against electrical breakdown. The film can therefore be used for both supplementary and primary space heating by installing in wall panels, ceilings and floors. At the same time, the heater is not designed for outdoor use without proper protection. The product is manufactured using a polymer film (polyester) with high dielectric values; it conducts infrared heat easily and is heat resistant. The carbon paste is applied to the polymer film with a technological precision of less than 1 micron. And the process of applying the carbon and other materials and the final lamination itself takes place at 140 °C (see figures 1 and 2).

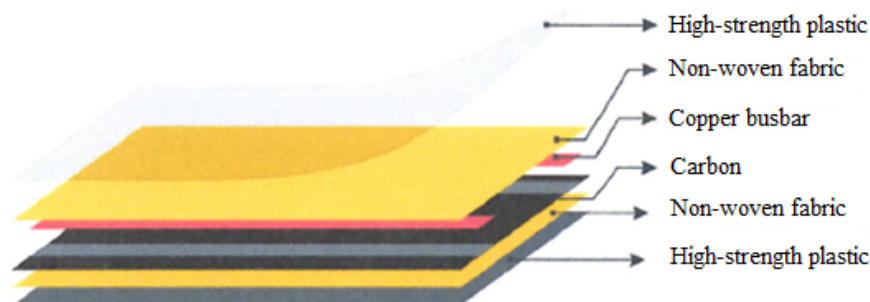

Fig.1. Infrared heating system film design

The aim of the current study was to investigate the use of an alternative energy source in the form of solar radiation and carbon-based fuel flexible material as a heater for heating mobile living quarters of farmers. The scientific novelty of the research is the possibility of using carbon-based fuel flexible material and solar energy in mobile living quarters.

2. Results and discussion

In order to conduct research on the application of a mobile residential heating system using solar panels and carbon-based flexible fuel material, a solar station and a heater with carbon-based flexible fuel material were installed on the farmer's mobile house (see Figures 2). Previously, a solar panel was installed on the house, the energy from which is used for lighting (in Figure 2a near the window). Solar plant includes two monocrystalline solar modules ZDNY-250C60 sized 1650x992x45 mm with capacity 250 W, PWM controller, sinusoidal inverter IS-24-1500U, two storage batteries with capacity 100 A/h. The angle of inclination of the solar panels is 55°.



a)



b)

Fig.2. Solar plant: a) solar panels; b) batteries, controller, inverter

The structure of the ZDNY-250C60 monocrystalline solar module consists of many silicon cells that convert sunlight into electricity (see figure 3) [12]. The advantages of these panels are the compactness, low weight and higher efficiency. The monocrystalline panels are placed in a robust and sturdy fiberglass enclosure that protects the photovoltaic cell from moisture and dust penetration. The technical characteristics of the ZDNY-250C60 monocrystalline solar module are shown in Table 1 [12].

Farmer's house: room height 2.5 m, width 2.4 m, length 4.2 m. During the research period, the temperature outside the room ranged from -16°C to -22°C; inside the room from -11°C to -16°C; wind speed - from 3 m/s to 6 m/s; the walls of the house are made of sandwich panels on a basalt base with a thickness of 50 mm; the floor was insulated with linoleum on a felt base.

Table 1. Technical characteristics of the ZDNY-250C60 monocrystalline solar module

<i>Indicator name</i>	<i>Value</i>
Maximum power, Pmax	250 W
Voltage at Pmax, Vm	31.17 V
Current at Pmax, Im	8.03A
Open circuit voltage, Voc	37.85V
Short circuit type, Isc	8.40A
Cell efficiency	17.4%
Panel efficiency	15.3%
Cell type	Monocrystal, 156x156 mm
Power deviation (Pmax)	+0..3%
Number of cells	60
Panel size, mm	1650x992x45
Weight, kg	22.5
Operating temperature	-40°... 85°C
Nominal operating cell temperature	47°C

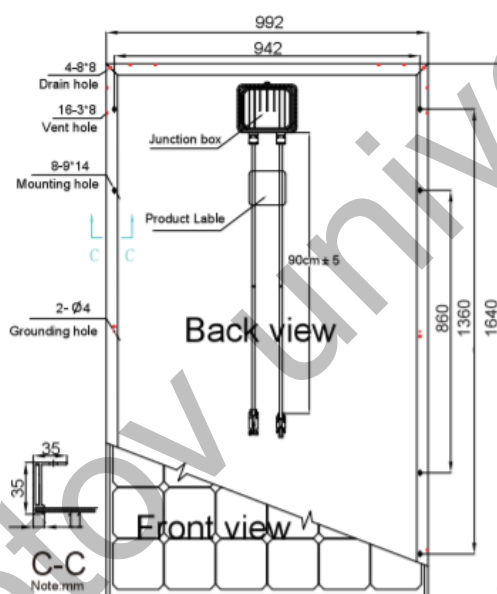
**Fig.3.** Monocrystalline solar module ZDNY-250C60

The heating system works as follows. The electric current from the two batteries is supplied to the inverter, which converts the direct current into alternating current and changes the voltage from 24 V to 220 V. The current from the inverter is then supplied to the heater with the carbon-based fuel material. To regulate the temperature of the carbon heater, a thermostat is installed between the inverter and the heater, which regulates the temperature of the carbon-based fuel material installed in the heater. During operation, the batteries are charged from the two solar panels via the controller.

In the course of the research, natural light was measured on different days and hours using the luxmeter "TKA-Lux", the current flow to the heater using the M266 current clamp, outdoor temperature, indoor temperature, battery condition using the discharge tester, and the temperature produced by the carbon heater using the Testo 875 thermal imager. The research was carried out in an unheated room.

In the course of research, the following results were obtained:

1. The power consumption of the carbon heater was between 480 W and 540 W at a constant voltage of 220 V and the electrical current was between 2.18 A and 2.45 A.
2. The maximum heating temperature of the carbon heater was +65 °C from the start after 3 hours, which was observed in particularly sunny weather with an illuminance of 91 klx. At the same time, the room temperature increased from -11 °C to 12-16 °C.

3. The state of charge of the two 100 A/h batteries varied from 14 V to 9 V for 3 hours under load. Also, the loss of battery charge occurred due to the low temperature inside the room. As a result, it was found that the capacity of the batteries and their number must be increased to ensure the normal operation of carbon heaters.

Conclusions

The research has shown that in order for the batteries to work properly, the indoor temperature must be maintained in accordance with the operating requirements. At low temperatures there is a rapid decrease of discharge and capacity. Cold temperatures affect different types of lead acid batteries in different ways, but are equally damaging for battery operation and performance. The electrolyte freezes and crystallises, which can damage the battery banks and the sponge plate material.

In our region, the daylight hours are considerably shorter in winter and there are more overcast days and the panels can no longer produce the same amount of energy. Therefore, there is a need to increase the number of solar panels and batteries in order to run the heater for a longer period of time. Compared to other systems, such as solar collectors, the heating system we offer has a number of advantages:

- less energy is expended to heat the the carbon-based fuel material than in the solar collector of liquid and air;
- a simpler design of the heating system;
- not significant heat losses, since the carbon heater is located inside the room;
- not complicated installation and transportation;
- the ability to use in mobile rooms;
- many studies have found that it is recommended to use solar photovoltaic panels rather than solar air and water heaters. Better to install more PV panels and use an efficient electric heater [13].

Acknowledgments

The research is funded by the Science Committee of the Ministry of Education and Science of the Republic of Kazakhstan (Grant № AP08956558).

REFERENCES

- 1 Murgul V.A. Capabilities of Using The Solar Energy for Energy Supply of the Dwelling Buildings of the Historical Area of Saint-Petersburg and for City Environment Quality Improvement. *Architecture and Modern Information Technologies*, 2013, No.1(22), pp. 22/13-07.
- 2 Izzet Yüksek, Tülay Tikansak Karadayi. Energy-Efficient Building Design in the Context of Building Life Cycle, Energy Efficient Buildings. *Eng Hwa Yap, Intech Open*, (January 18th 2017). DOI: 10.5772/66670.
- 3 Ghoreishi K., Fernández-Gutiérrez A., Fernández-Hernández F., et al. Retrofit planning and execution of a mediterranean villa using on-site measurements and simulations. *Journal of Building Engineering*. 2021, Vol. 35, Article 102218.
- 4 Solar heating of a detached house - what you need to know? 2021. Available at: <https://energo.house/sol/solnechnoe-otoplenie.html> (25.02.2021).
5. Selivanov N.P., Melua A.I., Zokolei S.V. *Energoactive buildings*. Moscow, Stroyizdat, 1988, 376 p.
- 6 Borutsky V. *Heating of a detached house with solar panels: schematics and system*. 2019. Available at: <https://sovet-ingenera.com/eco-energy/sun/otoplenie-na-solnechnyx-batareyax.html> (19.01.2021)
- 7 Solar module positioning, 2020. Available at: <https://s-ways.ru/blog/faq/7315.html> (04.03.2021)
- 8 Heating elements: Structure, selection, exploitation, installation of heating elements.2019. Available at: <http://electricalschool.info/main/ekspluat/238-trubchatye-jelektricheskie-nagrevateli.html> (26.02.2021)
- 9 Li C., Zhang B., Xie B., et al. Stearic acid/expanded graphite as a composite phase change thermal energy storage material for tankless solar water heater. *Sustainable Cities and Society*. 2019, Vol. 44, pp. 458 – 464.
- 10 Kogay I.V., Pak V.A., Chan L.S. *Method of manufacturing electrically conductive filament for electric heating fabric and apparatus for its implementation*. Patent No.17940 RK. Publ. 16.10.2006, Bull. 10, 1 p.
- 11 Kogay I. V. *Method of manufacturing electrically conductive filament for electric heating fabric and apparatus for its implementation*. International depository «INTEROCO». Berlin: European Union, 2015, No EU-000678, 3 p.
- 12 *Passport of monocrystalline solar module ZDNY-250C60*, China, 2020, 1 p.
- 13 Ryan McCarthy. *Why We No Longer Sell Solar Air Heaters*. 2019. Available at: <https://reductionrevolution.com.au/blogs/news-reviews/why-we-no-longer-sell-solar-air-heaters> (26.07.2021).