

DOI 10.31489/2022No3/60-68

UDC 621.311.24

RESULTS OF THE EXPERIMENTAL STUDY OF THE FLOW FIELD OF A STATIONARY AIR FLOW DURING THE OPERATION OF A FOUR-BLADE BIDARRIEUS-1 TURBINE

Yershina A.K.¹, Manatbayev R.K.², Baizhuma Zh.²

¹Department of Physics, Kazakh National Women's Pedagogical University, Almaty, Kazakhstan

²Department of Thermophysics and Technical Physics, al-Farabi Kazakh National University, Almaty, Kazakhstan, rustemmanatbayev@gmail.com

There are a great variety of wind turbine constructions but by their principle of operation they are divided into three main types - sail (Savonius wind power unit), propeller and airfoils (Darrieus wind turbine). At present, propeller-type wind-turbines are the most widely spread. They are produced on a commercial level in many countries. Other conditions being equal, the power produced by wind power unit (WPU) is proportional to the area being swept around by a wind wheel. Therefore, Megawatt propeller-type wind turbines have blades with the length of 40 and more meters. Only aircraft works with a highly-qualified personnel and corresponding equipment can produce such long blades of a specific shape. Of high interest have become airfoil wind turbines (Darrieus WPU) lately. They are of a simpler construction and have a quite high wind power utilization factor ($\xi=0.45$). In spite of the fact that this is a good index of WPU efficiency, the workers of al-Farabi Kazakh National University have developed a new version of a wind turbine which allows increasing 1.3-1.6 times the value of this coefficient. This apparatus is named a Bidarrieus unit. This paper presents the description of a Bidarrieus unit, the principle of its operation and the possibility of increasing the wind power utilization factor. Also, the results of testing an acting laboratory model in an aerodynamic tunnel

Keywords: wind turbine, Darrieus, Bidarrieus, two-rotor wind power turbine, wind power factor

Introduction

Recently, interest has appeared in wing-type wind turbines, called the Darrieus wind turbine, invented by the French engineer Darrieus in 1925. [1] The Darrieus apparatus has the following advantages over other wind turbines:

- 1) due to the vertical-axial rotation of the turbine, the change in wind direction does not play a role;
- 2) the swept area is not inferior to the propeller area;
- 3) the power generator and other equipment are located at ground level, which facilitates the construction of the large-capacity machine, maintenance, and repair;
- 4) structurally, they are relatively simple to manufacture and have a fairly high coefficient of wind energy utilization ($\xi=0.45$);
- 5) the relative noiselessness of the turbine rotation, due to the continuous flow around the working blades by the wind flow, since symmetrical NACA profiles are used here;
- 6) the Darrieus wind turbine allows a wide range of design versions of these devices.

Therefore, many firms are showing interest in vertical-axis wind turbines of the carousel type, in particular, the Darrieus turbine [1-4]. As it is known, the Darrieus construction has a single shaft of rotation and a rectilinear span associated with two oppositely located working blades. A distinctive feature of the proposed device is the use of the principle of autonomous operation of two coaxial shafts connected to the turbine and transmitting wind energy to two current generators. Thus, the power removed by the two direct current generators is summed up. For centering, the coaxially mounted rotation shafts are separated from each other by support bearings, which ensures their independent rotation: both coordinated in the same direction and in the opposite direction. The wingspan and rotor blades can be made in the form of NACA symmetrical airfoils. The rotation of the wind turbine occurs due to the action of lifting forces on the working blades. The working blade can be connected to the rotation shaft using a swing or troposkino method.

1. The main part. The principle of operation of vertical-axis wind power devices of the carousel type.

Currently, propeller-type wind turbines are widely used, which make it possible to increase the installed capacity of each installation to several megawatts. Like any mechanical apparatus, a wind turbine of this type has both positive and negative sides. The positive is the developed and mastered long-term technology, on the basis of which, at present, high-performance power plants are being created around the world. Nevertheless, while bringing significant benefits to the country's energy balance, they cause some damage to the environmental situation in these regions. For example, propeller wind farms produce significant disturbances due to the high level of turbulence in the atmosphere. The high and wide range of sound waves create unbearable conditions for surrounding living organisms. The higher the installed capacity of such wind farms, the larger the lifeless territory in these regions (birds, wildlife and local people leave these places). In this regard, Darrieus carousel-type wind turbines, operating on the lifting force of the working blades and having a NACA symmetrical wing shape, are becoming more preferable. At the same time, the overall dimensions of such devices are much smaller than propeller ones, with almost the same installed power values. The material consumption and the space occupied for these devices are incomparable with the propeller ones. The Darrieus wind turbine has a non-separated flow around the blade and, accordingly, is almost silent. These profiles (NACA-0021) have low drag at $\varphi=0$. [5,6]

$$\zeta_{xл} = C_{xл} \rho \frac{U^2}{2}, \quad \text{where } C_{xл}=0.028.$$

Whereas, if the blade of the same profile is deployed, with the trailing edge towards the wind flow, the resistance becomes an order of magnitude higher, due to the separation flow.

$$\zeta_{xк} = C_{xк} \rho \frac{U^2}{2}, \quad \text{where } C_{xк}=0.16.$$

In this regard, many companies give more and more preference to carousel-type devices. In addition, they allow the possibility of developing and creating various promising versions of wind turbines. At present, the theoretical foundations of Darrieus wind turbines have been developed [5,7].

A group of Kazakhstani scientists-enthusiasts for several years has been actively engaged in the development and modeling of various versions of carousel-type wind turbines with high utilization rates of wind energy at the Research Institute of Mathematics and Mechanics. New versions of the wind turbine have been developed, which allow, with the same swept area, to remove wind energy by 30-40% more compared to other wind turbines. Patents were received for several inventions [8,9]: wind turbine Bidarie-1, vertical-axial composite wind turbine HBI-rotor, wind turbine Bidarie-2, and organization of thermal protection of wind turbine operation under adverse climatic conditions. Schematic diagrams and photographs of the designs of the developed wind turbines are shown in fig. 1, 2.

The objective of the study is to develop a new modification of a carousel-type wind turbine with high technical and economic indicators. The mission of this study is to create a wind turbine at minimal cost and get the maximum of wind energy, which is in abundance in any region of our republic. A two-rotor wind turbine design is proposed, which allows to remove the maximum amount of wind energy. This design ensures the removal of the main element - the wind turbine, beyond the surface boundary layer and thereby allows you to remove wind energy in the area of potential wind movement, where the average wind speed is 2-3 times higher than the average wind speed of the surface boundary layer. This will allow the unit to begin to rotate spontaneously already at a wind speed of 5 m/s.

2. Features and principles of operation of Bidarrieus-1 wind turbines

The first version of two-rotor machines, called Bidarrieus-1, is quite widely known not only in Kazakhstan, but also abroad. The design of this wind turbine is a set of two Darrieus turbines as if nested in each other and deployed so that their spans are perpendicular to each other, i.e. $\alpha = 90^\circ$ [7-9]. Figure 1 shows various design schemes for the Bidarrieus-1 wind turbines. On the diagrams of Fig. 1, the following designations are accepted: 1 - blades, 2 - swings, 3 - housing, 4 - rotation shafts, 5 - bearing, $\alpha = 90^\circ$. In fig. 1a shows a variant with straight working blades (1) of an H-shaped rotor.

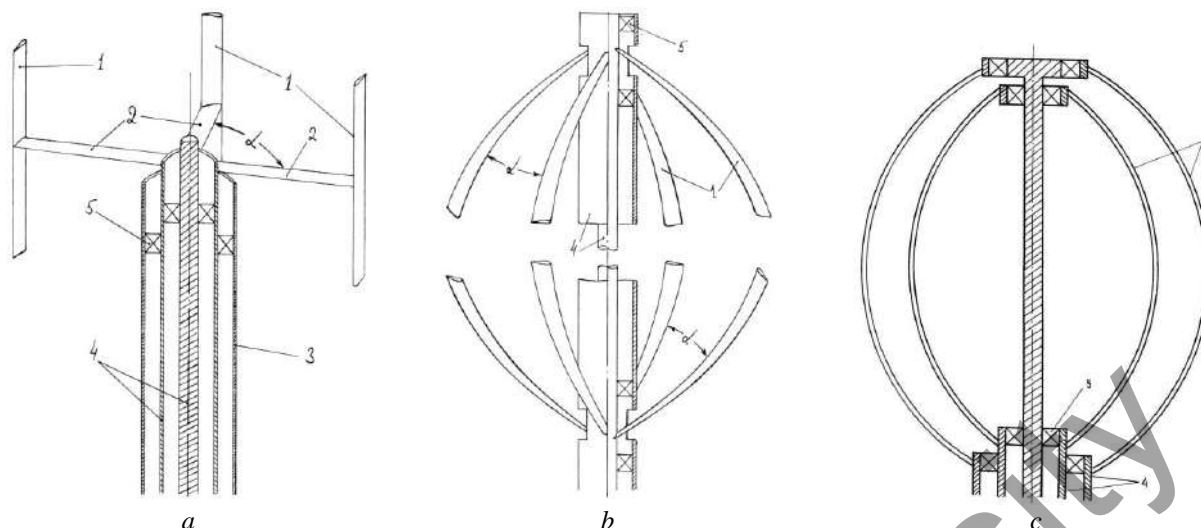

Fig 1. Schematic diagrams of the design of various wind turbines Bidarrius -1:
 a) with straight wings (one-way rotation); b) troposkino systems (one-way rotation); c) with troposkino blades (shaft rotation in different directions)

Each of the two coaxially located shafts (4) is connected with its symmetrically located pair of blades (1) by means of spans (2), which, during rotation, create a moment of forces that autonomously act on the “own” shaft. Figure 1b shows a diagram of the wind turbine Bidarie-1, but the blades are made in the form of a troposkino. The stability of the wind turbine is achieved by the symmetrical arrangement of the blades. Fig. 1c describes the design that allows the rotation of the shafts in different directions. In this embodiment, both shafts must rotate in the same direction with the same angular velocity. There is a special corrective device (clamp) that maintains the angle between the spans $\alpha = 90^\circ$ when Bidarrius-1 is operating [8].

3. The laboratory model of Bidarrius-1

In the course of research, for testing in a wind tunnel, an operating laboratory model of the Bidarrius -1 wind turbine was initially made (Fig. 2). The dimensions of the model are chosen so that it fits freely in the working section of the wind tunnel. Each pair of blades is connected by mutually perpendicular spans so that each of the four blades of the Darrieus wind turbine model is located at an angle of 90° to each other, Fig. 1a. The working section of the wind tunnel has an elliptical shape, the major axis of which is located horizontally.



Fig. 2. Laboratory model of the Bidarrius -1 twin-rotor wind turbine of JSC Research Institute “Gidropribor”, Uralsk: side view.

The current model has the following dimensions: total height 785 mm; the span on which four working blades are located is 800 mm. The working blades and both spans were made in the form of a symmetrical NACA-0021 profile. The blades and spans have the same chords, 32 mm long, the length of the working blades is 550 mm, the length of the spans is 400 mm. The proposed device is placed in one housing and consists of two coaxially located shafts of rotation connected with the working blades using spans. A distinctive feature of the Bidarrieus-1 device is the use in the design of the principle of autonomous operation of the shafts connected to the wind turbine and transmitting wind energy to two electric generators. When conducting experiments to determine and compare the values of wind energy utilization factors, the model worked both in the Darrieus mode and in the Bidarrieus-1 mode. The test results at various air flow rates showed the efficiency of the Bidarrieus-1 twin-rotor machine.

4. The methodology of the experiment and the results of the experimental study

The experiments were carried out on a working laboratory model of a wind turbine with straight working blades in a wind tunnel of JSC Research Institute "Gidropribor". The flow characteristics were measured in the working section of the wind tunnel. The model is a two-bladed version with vertical straight working blades mounted on horizontally directed strokes, rotated by 180° . The working blades and swings are symmetrical NACA-0021 profiles. Two such two-bladed wind turbines are mounted on two coaxial shafts that can rotate independently of each other. The dimensions of the wind turbines are identical and the four working blades are located at the same distance from the common axis of rotation, in other words, the length of the strokes is the same. Strokes are attached to the top of the shafts. Each of the coaxial shafts below has a pulley, with the help of a belt drive, two independently operating electric generators rotate. Wind turbines are rotated relative to each other by 90° , so that the turbine strokes are a cross with right angles. For independent rotation of the turbines, there is a special device that maintains this angle constant. Thus, each turbine rotates its own shaft and transmits torque to one of the electric generators. Such a device is the Bidarrieus-1 model, capable of simultaneously rotating 2 electric generators.

The design allows you to remove one of the turbines connected to the inner shaft. In this case, we will have the well-known two-bladed Darrieus turbine model, which, through the rotation of the shaft, transfers energy to one electric generator. As a result, it is possible to compare the power developed by the wind turbines "Bidarrieus-1" (the total capacity of two electric generators) and "Darrieus" under all other identical conditions. The dimensions of the wind turbine are chosen so that the model fits completely in the working section of the wind tunnel. This is an open area of elliptical shape with dimensions: length - 2.2 m, the major axis of the ellipse - 2.1 m is located in the horizontal direction, and the minor axis - 1.2 m. The airflow in the working area moves in a horizontal direction at a speed of up to 35m/s (Fig.3).

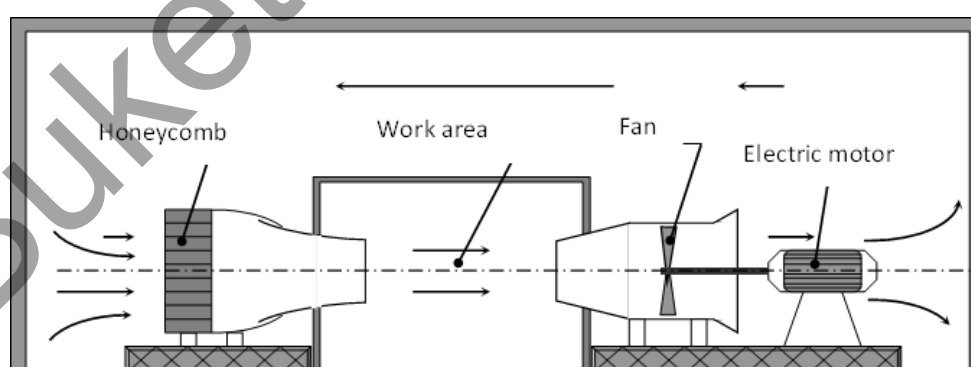

Fig.3. Schematic diagram of a wind tunnel.

The model was mounted in the central part of the working section of the wind tunnel across the flow so that the plane of rotation of the flywheels lay in the central plane of the working section passing through the major axis of the ellipse, and the axis of rotation of the turbine was directed along the minor axis of the ellipse. Model dimensions: height from the pulleys to the plane of rotation of the flaps - 0.51 m, length of the flaps from the turbine axis to the chord of the working wings, equal to the radius of rotation - 0.404 m, length of the working blade (T - shaped mount) - 0.55 m, chord profile of the working blades and shoulders - 0.03m (NACA-0021 profile).

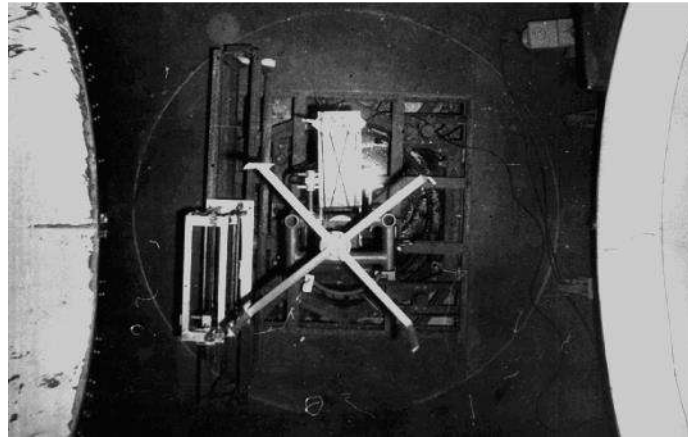

Fig.4. Operating laboratory of the Bidarrieus -1 turbine model in the wind tunnel working section (top view).

The possibility of quantitative recording of the power developed by the turbine made it possible to carry out four series of experiments. We were interested in the repeatability of the results obtained, as well as the expansion of the experimental data with the variation of various elements of the electrical part. In each series of experiments, measurements were made with the rearrangement of electric generators, connecting them with a belt drive to one or another shaft. Similarly, the rheostats were interchanged during power removal, and the current and EMF measurements were carried out either with one device or with another. The data obtained are summarized in Table 1. The last column of the table (the rightmost column) shows the power received in the "darier" mode, and the total power of the two electric generators when the turbine is operating in the "Bidarrieus-1" mode. As can be seen from the table, in all experiments, the total power of the "Bidarrieus-1" was 30-40% higher than that of the "Darrieus".

At the end of the power tests, an aerodynamic experiment was carried out using a three-channel probe to analyze the distribution of the velocity and pressure field in front of the turbine, inside the cylindrical surface swept by the rotor blades, and also behind, behind the wind turbine.

Research was planned to measure the magnitude of the speed, as well as the distribution of pressure in front of and behind the wind turbine. In addition, measurements were taken inside a cylindrical cavity described by rotating working blades (sweeping surface). All measurements were carried out in the horizontal plane of rotation of the swings. Thus, the influence of the end effects of the working blades, which were sufficiently removed from the measurement plane, was excluded.

This made it possible to use a three-channel Pitot-Prandtl nozzle. The speed of the air flow in the working section of the wind tunnel was controlled by a conventional full-pressure tube. Since the working section of the wind tunnel was rarefaction, the value of the latter was measured in each operating mode of the wind tunnel. In order to improve the accuracy of measurements, the main studies were carried out at a flow velocity in the working section of the wind tunnel equal to 17 m/s. In this case, the angular velocity of rotation of the turbine was 43.96 rad/s ($n = 420$ rpm). The measurement accuracy with a three-channel probe using a cup micromanometer was 1 mm of water. The limb of the three-channel probe, equipped with a vernier, made it possible to measure the angle of rotation of the measuring probe with an accuracy of $\sim 0.1^\circ$. The measuring probe was mounted on a coordinator, with the help of which it was possible to move in the horizontal direction with an accuracy of 0.1 mm. The coordinate was located below the cylindrical surface described by the rotating working blades of the turbine. The holder of the three-channel measuring probe was fixed vertically, parallel to the side surface of the swept cylindrical body so that the receiving openings of the measuring probe were directed towards the air flow and located in the plane of rotation of the swings. When measuring inside the swept cylindrical body, the receiving holes were located 50 mm below the swings.

The obtained experimental data were processed in dimensionless quantities:

$$\bar{p} = \frac{P_{cm} + P_\infty}{P_\infty}, \quad \bar{V} = \frac{V}{V_\infty}, \quad \bar{r} = \frac{r}{R}$$

where P_{str} is the static pressure according to the readings of the three-channel probe, P_∞ is the pressure in the working chamber, ρ is the air density determined from barometric readings, V_∞ is the air velocity in the working area when the Darrieus model is stationary, R is the radius of the swept cylindrical surface.

Table 1. The results of tests of wind turbines "Darrieus" and "Bidarrieus-1"

Experience number	MODE		No-load		Work with load				
			RPM	Generator emf, V	RPM	Voltage of generator, V	Amperage, mA	Total power, W	Power, W
I-series of experiments									
1.	2-bladed "Darrieus"	(1 engine)	800		450	3	130	0.39	0.39
2.	«Bidarrieus»	(1 engine)	700		400	2.5	110	0.275	0.55
		(2 engine)	700		400	2.5	110	0.275	
II-series of experiments									
1.	2-bladed "Darrieus" rheostats 2.1	(1 engine)	500	5	450	3	100	0.3	0.3
2.	«Bidarrieus-1» rheostats 2,1	(1 engine)	400	3,8	350	2,2	95	0.21	0.386
		(2 engine)	400	3,8	350	2,2	80	0.176	
3.	«Bidarrieus-1» rheostats 1,2	(1 engine)	400	3,8	350	2,4	80	0.19	0.41
		(2 engine)	400	3,8	350	2,2	100	0.22	
III-series of experiments, swapped engines									
1.	«Bidarrieus-1» rheostats 1,2	(2 engine)	420	4	390	2.5	90	0.225	0.435
		(1 engine)	420	4	390	2.2	95	0.21	
2.	«Bidarrieus-1» rheostats 2,1	(1 engine)	450	4	390	2.4	85	0.204	0.468
		(2 engine)	450	4	390	2.4	110	0.264	
3.	"Bidarrieus-1" with tight springs rheostats 2.1	(2 engine)	400	3.4	300	2.0	70	0.14	0.338
		(1 engine)	400	3.4	300	2.2	90	0.198	
4.	2-bladed "Darrieus" rheostats 2,1	(2 engine)	500	4.5	400	2.9	125	0.36	0.36
5.	2-bladed "Darrieus" rheostats 1,2	(2 engine)	500	4.5	420	3	105	0.315	0.315
IV-series of experiments, swapped engines									
1.	«Bidarrieus-1» rheostats 2,1	(2 engine)	450	3.8	350	2.2	100	0.22	0.472
		(1 engine)	450	4	350	2.4	105	0.252	
2.	«Bidarrieus-1» rheostats 1,2	(1 engine)	450	3.8	380	2.2	120	0.264	0.498
		(2 engine)	450	4	380	2.6	90	0.234	
3.	"Bidarrieus-1" with tight springs rheostats 1.2	(2 engine)	400	3.2	350	2.0	120	0.24	0.465
		(1 engine)	400	3.4	350	2.5	90	0.225	
4.	"Bidarrieus-1" with tight springs rheostats 2.1	(2 engine)	400	3.2	320	2.2	90	0.198	0.438
		(1 engine)	400	3.4	320	2.4	120	0.24	
5.	2-bladed "Darrieus" internal shaft rheostats 1.2	(1 engine)	500	4.5	400	2.6	120	0.312	0.312
6.	2-bladed "Darrieus" internal shaft rheostats 2.1	(1 engine)	500	4.5	420	2.8	100	0.28	0.28

The main dimensions are shown in figure 5. Experimental plots are presented in dimensionless terms. The Figure 5 shows the experimental profiles \bar{p} obtained in five sections (in front of the turbine, inside the rotating turbine, then in three sections after passing the turbine) in which the measurements were made. A

schematic representation of the cross sections of the airflow in the working area with a rotating model of the Darrieus wind turbine is shown in Figure 6.

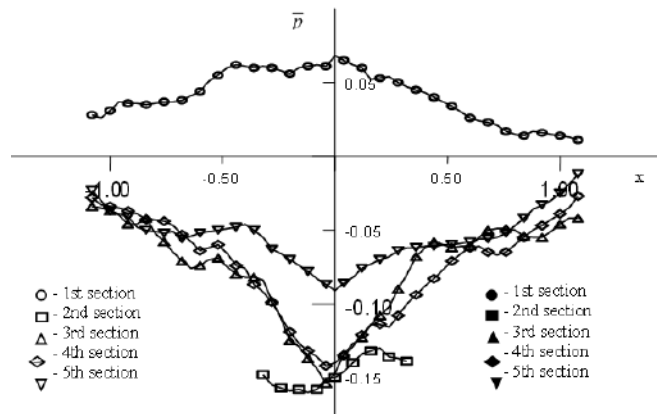

Fig. 5. Experimental data on the distribution of pressure in various sections of the air flow during turbine operation

As can be seen from the graph, the pressure in front of the rotating turbine is positive. Naturally, near the central line, the flow deceleration is significant; accordingly, the pressure is higher. As you move away from the center line on both sides, the flow deceleration weakens, and the pressure tends to the pressure inside the working chamber (P_∞). The lowest value of static pressure was shown by measurements in the next section, which was made inside a cylindrical cavity bounded by the swept surface. The next three sections, as seen in Fig. 3 were located in the wake of the rotating turbine. The data in Fig. 3 clearly shows the process of pressure recovery as you move away from the wind turbine; the results of measuring the static field reflect the physics of the phenomenon.

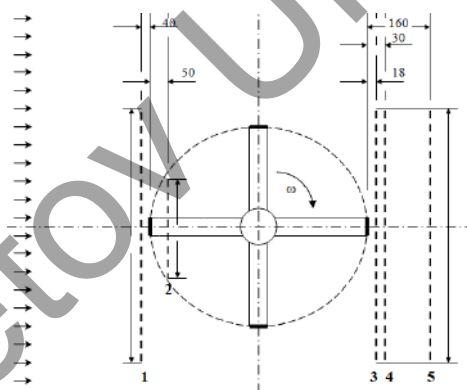

Fig. 6. Schematic representation of the cross sections of the air flow in the working area from the rotating model of the wind turbine Darrieus.

Finally, it is of interest to consider the nature of the curvature of the streamlines during the passage of an airflow through a wind turbine. The deviation of the flow from rectilinear motion is already observed when approaching the turbine. The streamlines begin to deviate slightly ($2-2.5^\circ$) from straightness when they meet the rotating blades. Moreover, the greatest deviation takes place in the area of oncoming flow and blades (quadrant I in Fig. 8). In the area of the outgoing movement of the blades (quadrant II in Fig. 8), the deviations do not exceed $(0.5-1)^\circ$, i.e. within measurement error. The same thing happens on the leeward side of the swept surface. The streamlines here in quadrant IV (Fig. 8) also deviate toward the moving working blades. However, it is noticeably stronger ($5-6^\circ$). In quadrant III, the deviations are very weak.

On fig. Figure 7 shows the measurement data of the velocity field in the same five sections. In the upper part of the graph, there are velocity profiles (dark dots), below the values of their cubes are given in order to be able to estimate the loss of wind energy when passing through a rotating wind turbine (the notation is the same as in Fig. 5). In order to consolidate the illustrative material and provide an opportunity for a more detailed study of the experimental profiles, they are somewhat shifted relative to each other.

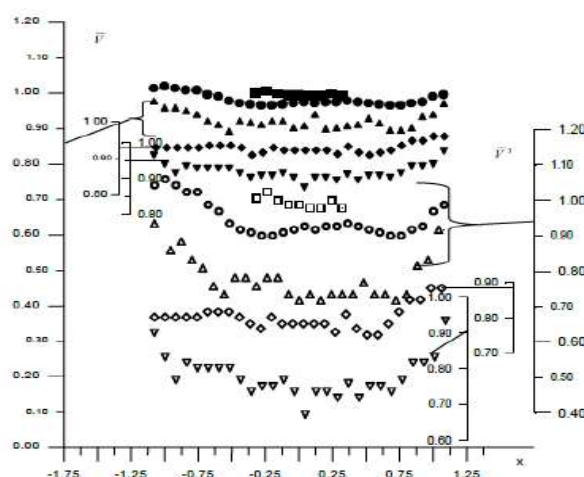

Fig.7. Plots of speeds and energy of the air flow in several sections during the operation of a four-bladed Darrieus wind turbine.

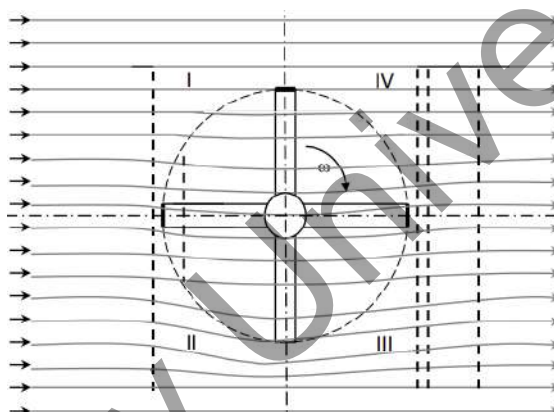

Fig.8. Streamlines plotted based on velocity direction measurement data

Otherwise, it is difficult to get a clear perception of the measurement results due to the overlap of measurement data of different cross-sections. It is easy to see that the air slows down in front of the wind turbine and accelerates somewhat in the second section, which is obviously due to a significant rarefaction of the leeward side of the working blade. As for the three sections behind the wind turbine, where the velocity field changes little (see coordinate scales), which is associated with the use of part of the energy of the airflow by the rotating turbine. This can be seen from the data \bar{V}^3 characterizing the energy of the airflow. Then the streamlines are straightened, going into the receiving part of the wind tunnel. Similar patterns should be observed in natural conditions, the wind flow deviates to one side when it meets the turbine, and to the other on the leeward side. The streamlines then apparently take the general direction of the wind.

Conclusions

The universal laboratory model of a carousel-type wind power plant made it possible to study both in the "Darrieus", and "Bidarrieus" modes. In this regard, the following tests were carried out:

1. Testing the model in the Darrieus mode at idle to determine the nature of its rotation in the airflow.
2. Tests of the Darier model with current generators.
3. Several series of experiments were carried out with the model in the "Darrieus", and "Bidarrieus" modes in order to obtain comparative characteristics, which is the main task of the tests.
4. At the end of the power tests, an aerodynamic experiment was carried out using a three-channel probe to analyze the distribution of the velocity and pressure field in front of the turbine, inside the cylindrical surface swept by the working blades, and also behind, behind the wind turbine

5. On the basis of a direct physical experiment, experimental data on the distribution of velocity, pressure and the nature of the change in the streamline near the operating wind turbine were obtained.

6. Despite the fact that this is a good indicator of the efficiency of the Darrieus turbine, the authors have developed a new version of the turbine, which allows increasing the effective value of this coefficient up to 1.5 times

REFERENCES

- 1 Darrieus F.M. *Turbine Having in Rotation Transverse to the Flow of Current*, US Patent 1.834/ 018 Dec. USA, 1931, 3 p.
- 2 Tjiu W., Marnoto T., Mat S., Ruslan M.H., Sopian K. Darrieus vertical axis wind turbine for power generation I: Assessment of Darrieus VAWT configurations. *Renewable Energy*. 2015. Vol.75, pp. 50 –67.
- 3 Tjiu W., Marnoto T., Mat S., Ruslan M.H., Sopian K. Darrieus vertical axis wind turbine for power generation II: Challenges in HAWT and the opportunity of multi-megawatt Darrieus VAWT development. *Renewable Energy*. 2015. Vol.75, pp. 560–571.
- 4 Paraschivoiu I. *Wind turbine design e with emphasis on darrieus concept*. Quebec: Presses Internationales Polytechnique; 2002, 483 p.
- 5 Yershina A. K., Yershina Sh. A., Zhabbasbayev U.K. *Fundamentals of the theory of Darreus wind turbines*. Almaty, Kazgos INTI. 2001, 104 p. [in Russian]
- 6 Wang Y., Shen S., Li G., Huang D., Zheng Z. Investigation on aerodynamic performance of vertical axis wind turbine with different series airfoil shapes. *Renewable Energy*. 2018. Vol. 126, pp. 801–818.
- 7 Gorelov N.D. Energy characteristics of the Darrieus rotor (review). *Thermophysics and Aeromechanics*, 2010. Vol.17, pp. 301 – 308.
- 8 Yershina Sh., Yershina A.K., Ydyryssova A.A. Vertical–axial two–rotor wind power units Bidarrieus-1. *Eurasian Physical Technical Journal*. 2017. Vol. 14, No. 2(28), pp. 108 – 112.
- 9 Kumar R., Raahemifar K., Fung A.S. A critical review of vertical axis wind turbines for urban applications. *Renew. Sustain. Energy Rev*. 2018. Vol. 89, pp. 281 – 291.

Article accepted for publication 28.08.2022