

UDC 621.314; 537.39

INVESTIGATION OF THE NATURAL MINERAL QUARTZ TREATED UNDERWATER ELECTRIC DISCHARGE

G.M.Shaimerdenova, G.A. Bulkairova, K.K. Sadenova, M.N. Sagimbekova

Karaganda State University named after E.A. Buketov, Universitetskaya Str.28, Karaganda, 100026, Kazakhstan
mereke_sn_93@mail.ru

Article is discusses the results of studies of the electrohydraulic method of destruction of natural mineral quartz. Examined some types of quartz and its use in production. The electroimpulse technology is one of acceptable methods of crushing and milling of natural minerals. Shows the results of laboratory tests obtained with different diameters fractions. Information obtained from the milling of metallurgical silicium with help of offered technology in the future can be applied in production.

Keywords: electrohydroimpulse installation, electrohydraulic effect, quartzite deposit of "Nadyrbay", crushing.

The growing consumption of fuel, ferrous, nonferrous and rare metals, no metal ore materials, which are the basis for the development of modern industry, requires an increase in volumes of mining and mineral processing. Together with no metal ore, construction materials and mining chemical raw material the volume extraction and processing of fossil world several billion tons per year.

Recycling most mined rock mass means crushing and grinding it as preparatory process to direct enrichment. These processes are quite expensive and get to 50 % and in some cases 70 % of the costs of the concentrators. Great importance for the subsequent manufacturing operations has quality of crushing and grinding, involves getting the product without overgrinding with the given size with a maximum exemption of grains of minerals from the gangue with minimum of damage to them. Requirements increase the amount of recycled rocks and ores with improved processing quality indicators (increase recoveries) pose very urgent tasks to streamline processes and reduce the cost of crushing and milling.

Quartz is the most common mineral with the chemical composition of SiO_2 (46,7 %-Si; 53,3% O_2). Crystals of quartz extremely rarely get to this composition, as it usually embody various impurity: bubbles of gas and liquids, sometimes ingrown leaves mica. Quartz of high chemical purity and thermally stable is used in semiconductor industry as a material for crucible, furnace cameras, holders and etc. Quartz in the form of quartz glass is one of the essential materials in optical industry. It is used in production of optical equipment, telecommunication devices, diffraction lenses, projection displays, scanning devices and printers, lasers, photo cameras, video cameras, superflat TV displays, flame control devices and etc. the most important application of quartz is its usage in techniques, especially as piezoelectric. Ceramics uses various types of quartz feedstock: quartz sand, vein-quartz, quartz wastes, produced during enrichment of kaolines, Tripoli and diatomite. Low grade quartz is mainly used in metallurgy as flux and raw for technical silicon and castable production, in chemical industry as flux, in building and glass production [2].

In practice, ground (crushed) quartz is widely used in various industries: refractory industry, metallurgy, ceramic, glass, construction industry, fiber optics industry and in jewelry.

Kazakhstan has large reserves of raw quartz-bearing, but the main part is used in the production of simple construction materials, and only a small in a high-tech industries. The largest deposit in the Karaganda region is Aktas, Nadyrbay which is located near the town of Dzhezkazgan. Similar deposits are in Kokshetau and Pavlodar districts.

Quartzite deposit of "Nadyrbay" used in this article as the main material, presented quartz particles milky -white and grayish-white. Found in small amounts of grain with inclusions of light-brown color.

In this article given the results of studies of the electrohydraulic method of destruction and grinding quartz for mineral particles specified parameters.

When grinding ores, usually, the task is obtaining the minimum amount of slimy fractions. In abrasive, refractory and ceramic industry are faced with problems of obtaining products of narrow size fractions, the ability to control grain size characteristics is one of the main indicators of the method of destruction, determining its competitiveness.

Method of electric pulse is the physical destruction of the prerequisites for regulating particle size distribution. It is primarily the possibility of broad adjustment of energy in the discharge channel and time of allocation, and ability to control the failure modes such as pulse repetition in combination with the design of the electrode systems and circuits processing.

One of the features of the process is transformation electric energy to mechanic energy is carried out without intermediate links, which efficiency of the setup and provides safe, durable work. Suggested way of grinding minerals is based upon usage of energy of impulse knock wave, occurring as a result of spark electric charge in liquid. This method of grinding is perspective, economically efficient, ecologically clean and easily included in the setup.

Basic experiments on fragmentation and destruction of the mineral quartz conducted for ore deposit of Nadyrbay.

Since the original quartz ore was a great size and weight, before the research, it was mechanically subjected to crushing to the certain fraction.

Experiments were performed at the different values of the energy discharge, capacity of the capacitor bank, the interelectrode distance on a dialup device, also changed the pulse repetition frequency electrohydraulic effect. The applied voltage is controlled by the switching device 10 to 40 kV.

To study the effect of electrohydraulic effects on the degree of crushing and grinding of the mineral quartz in the laboratory of Engineering Thermophysics electrohydrodynamics KSU named E.A Buketova was designed and assembled experimental setup, working part of which is shown in Fig.1.

Installation consists of: a cylindrical body 1, the working electrode 2, a cover 3, caprolan washer 4 and caprolan sleeve 5.

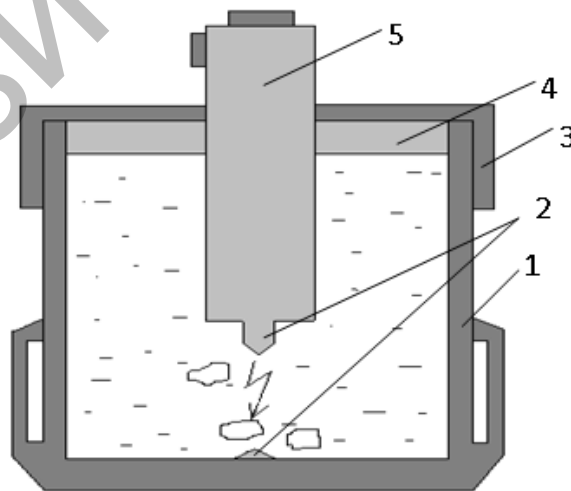

Fig.1. Working part of an experimental stand for crushing mineral quartz

Electrohydraulic method uses pulse shock wave, resulting from the non-linear phenomena in the liquid spark. Such a method of crushing promising, economical, environmentally friendly, can be easily integrated into any technological chain.

In the experiments investigated the degree crushing quartz K , which was determined by the value of the discharge energy. In the graph (Fig.2,3) presents the results of the laboratory tests, which carried out at different values of diameters fractions of quartz and electrode spacing on the switching device electro installation.

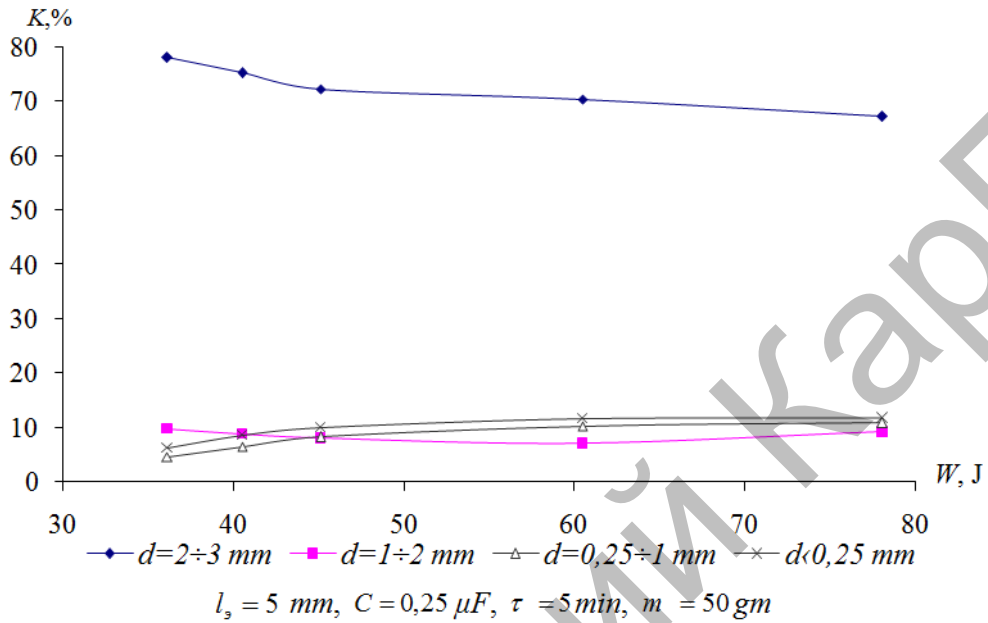

Fig.2. Dependence of the degree of crushing quartz discharge energy on the switching device

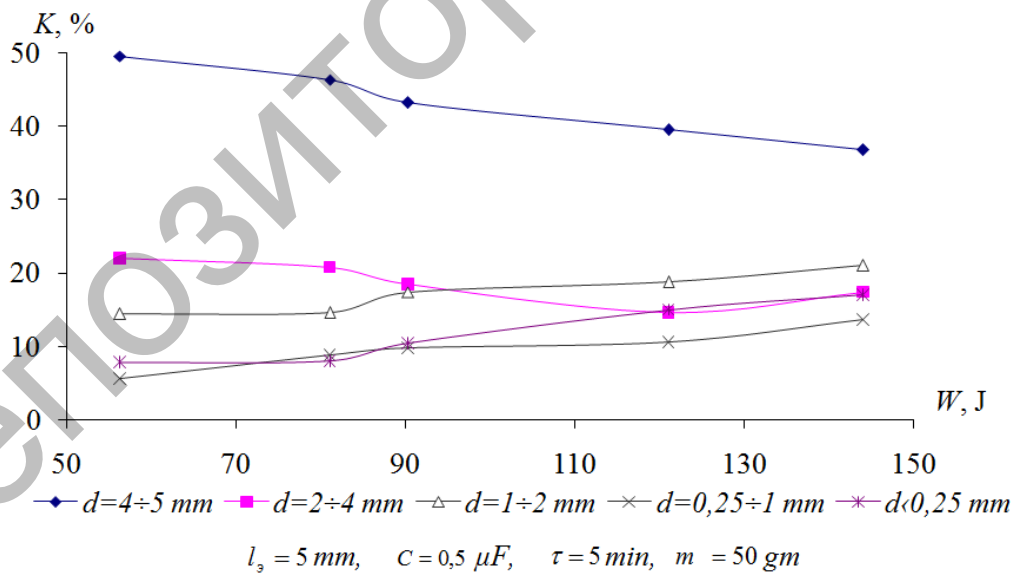

Fig.3. Dependence of the degree of crushing quartz discharge energy on the switching device

When the initial value of the discharge energy $W = 36,1$ J and the discharge gap length equal to $5 \cdot 10^{-3}$ m, the degree of coarse fractions ($d_\phi = 2 \div 3$ mm) composes 78% fines ($d_\phi < 0,025$ mm) -

6.2%, and at the energy of the discharge on the switching device $W = 78.1$ J coarse fractions ($d_{\phi} = 2 \div 3$ mm) reduced to 67.2%, fines ($d_{\phi} < 0,025$ mm) increases to 11.8% of the feedstock.

When the initial value of the discharge energy $W = 56,2$ J and the discharge gap length equal to $5 \cdot 10^{-3}$ m, the degree of coarse fractions ($d_{\phi} = 4 \div 5$ mm) composes 49.6%, fines ($d_{\phi} < 0,025$ mm) - 7.8%, and a value of discharge energy on commuting device $W = 144$ J coarse fractions ($d_{\phi} = 4 \div 5$ mm) reduced to 36.8%, fines ($d_{\phi} < 0,025$ mm) is increased to 17% of the feedstock.

From these graphs it can be concluded that with increasing values of the discharge energy particle with less diameter crushed intensively. The proposed method of treating aqueous suspension electro quartz allows you to quickly and cost-effectively get quartz powder of a certain size, while simultaneously improving the sanitary conditions of work and significantly reduce pollution.

In practice electrohydraulic effect in comparison with other techniques showed that the efficiency of crushing the mineral quartz increased by 10%.

REFERENCES

1. A.I.Rodygin Microstructural analysis of quartz (with guidance and examples of geological interpritatsii). 1994,M.,Tomsk,- P.3-13.
2. L.A. Yutkin Electro-effect and its application in industry.1986, L: Mechanical Engineering, Leningrad.otd th, 253 p.
3. V.I. Kurets, A.F. Usov, V.A. Tsukerman Electro pulse disintegration of materials. 2002, Apatity: Izd.Kolskogo Scientific Center RAS, 324p.
4. K.K. Kusaiynov, B.R. Nusupbekov, G.A. Bulkairova Structural and chaotic patterns of destruction of the mineral quartz, Proceedings of the University (Cargo). Heat exchange and pulse phenomena in multiphase media. Karaganda: Izd.KarGU, 2008.-P.52-58
5. K.K. Kusaiynov, G.A. Bulkairova, G.S.Omarova, A. ZH. Tleubergenova, M.N.Sagimbekova Investigate the effect of underwater electrical discharge to natural mineral quartz crushing // Proceedings of the International Scientific Conference "Chaos and structures in nonlinear systems. Theory and experiment ", dedicated to the 40th anniversary of the University named after academician E.A. Buketova. Karaganda: Izd.KarGU, 2012.- p.643