

A.Zh. Tleubergenova<sup>\*1</sup>, N.K. Tanasheva<sup>1</sup>, K.M. Shaimerdenova<sup>1</sup>, L.L. Minkov<sup>2</sup>,  
A.N. Dyusembaeva<sup>1</sup>, S.Zh. Uzbergenova<sup>3</sup>

<sup>1</sup> Karaganda University of the name of academician E.A. Buketov, Kazakhstan;

<sup>2</sup> National Research Tomsk State University, Tomsk, Russia;

<sup>3</sup> Sh.Ualikhanov Kokshetau University, Kokshetau, Kazakhstan

\*E-mail: [shymkent.a7@mail.ru](mailto:shymkent.a7@mail.ru)

## Study of aerodynamic parameters of the sail blade

This article studies the aerodynamic characteristics of a triangular sail blade of various parameters. For this purpose, we made a triangular sail blade with a dynamically changing surface shape. The airflow velocity varied from 3 to 12 m/s. The dependences of the aerodynamic forces of the sail blade on the flow velocity were investigated at various angles of the apex of the triangular blade. The experiments were carried out at different vertices of the angles:  $0^{\circ}$ ;  $30^{\circ}$ ;  $60^{\circ}$ ;  $90^{\circ}$ . As a result of the experiment, it was revealed that at the vertex angle  $\gamma = 90^{\circ}$ , the triangular sail blade has optimal aerodynamic parameters. The dependences of the aerodynamic coefficients on the dimensionless angle of attack are obtained. It is found that the optimal number of triangular blades for a wind power plant with sailing blades is 6. It is established that at the angle of attack  $\alpha = 0^{\circ}$ , the maximum value of the middle section of the wind wheel to the streamlined airflow will introduce a decrease in the value of the drag coefficient with an increase in attack  $\alpha$ . The analysis of the experiment results on the change in  $\alpha$  from the speed of the airflow of the sail blade is carried out. When the blade position changes, drag changes relatively to the airflow. The wind wheel will change its position relative to the stream with an increase in the attack angle. With an angular position change, the area of the middle section of the wind wheel begins to decrease relative to the incoming flow. With a decrease in the middle section of the wind wheel, the drag force decreases, and the drag coefficient decreases accordingly. Thus, the total result of pressure changes on the leeward and windward surfaces of the sail can be represented as one resultant aerodynamic force directed at an angle to the line perpendicular to the wind direction.

*Keywords:* sail, wind turbine, flow speed, aerodynamic force, wind tunnel T-1-M, attack angle.

### Introduction

The wind potential of the area primarily determines the development of the wind energy industry in Kazakhstan. The wind resource of the Republic of Kazakhstan is rich and has no territorial boundaries. Over 50 % of the country's territory has wind with speeds of 3–4 m/s, and in some open areas, one can observe higher wind speeds of 6 m/s and higher.

Foreign and domestic scientists and engineers have developed wind power plants with wind speed limits for starting work. These installations are designed for wind speeds ranging from 5–6 m/s. Based on this, an urgent issue arises in developing and studying wind power plants and their working power elements for low speeds of the air oncoming flow.

One of the representatives of wind power plants for low wind speeds is wind power plants with dynamically variable blade surfaces (a sail); the threshold speed for starting the installation is 3 m/s.

Invention [1] aims to increase the windage of the blades and increase the efficiency of using wind energy. Gandhi et al. [2] investigated the combined operation of solar photovoltaic installations with wind power installations with sail blades. A distinctive feature is that the sail blades are square-shaped.

Ghosh et al. [3] provided the study of the aerodynamic characteristics of a Cretan-type wind turbine, a wind turbine with a horizontal sail-type axis. Ignazio et al. [4] presented the pressure tendencies for different angles of attack of the sail. Finally, He et al. [5] determined the sail model's performance coefficients and the sail's optimal attack angle based on the results of tests in a wind tunnel. Jean-Baptiste [6] gave a detailed overview of various features of leeward sail flow, including the effect of separation bubbles and vortexes at the leading edge.

Blades with a dynamically changing surface shape solve the problem of increasing the wind energy utilization factor with an air incoming airflow with minimal values. The explanation for this is that when the air flows around the oncoming flow, favorable conditions are created, which, in turn, are also close to continuous flow, entailing an increase in the lift coefficient of the blades. For this purpose, the blades have the shape of a triangular sail. During the conversion of the energy of the airflow by the sailing blades into energy con-

venient for use, aerodynamic forces appear. The thrust force, which is part of the aerodynamic forces, contributes to the rotational movement of the wind power plant. The change in the value of the aerodynamic force is influenced by a change in the pressures, namely, a change in dynamic and static pressure when the blades are blown by the wind [7].

The airflow in front of the sail blade is divided into two parts: leeward and windward. The cross-section of the wind flow will be smaller than the cross-section of the initial flow from the wind side, and the speed, respectively, is greater than the actual wind speed. Considering Bernoulli's Law, the atmospheric pressure on the leeward side of the sail can be said to be less than atmospheric pressure. Most of all, the speed will increase in the front part of the sail, where there will be an area of slightest pressure, or, in other words, the most significant vacuum [8].

By similar reasoning, it is easy to establish that on the windward side of the blade, the wind speed will decrease slightly in the area of the front part of the sail. As a result, the static pressure will increase and become higher than the atmospheric pressure, i.e. there will be additional pressure above the existing atmospheric pressure. Thus, the useful work of the sail will be caused by the fact that pressures that differ in magnitude from atmospheric pressure will form on it. Their action is directed perpendicular to the sail fabric, and the value changes depending on the difference in the air flow rate at a given point.

The purpose of this work is to study the aerodynamic forces and their coefficients of the blades in the form of a triangular sail of a wind power plant.

### *Experimental*

The authors of the work conducted laboratory experiments to study the aerodynamic forces of the sail blade. During which, the optimal linear dimensions of the triangular sail were determined. Tests of a sail blade with a movable end were carried out in the T-1-M wind tunnel (laboratory of Aerodynamic measurements), where it was fixed in the working part of the pipe. The values of the airflow velocity varied from 3 to 12 m/s.

In the proposed work, a study was carried out for an optimized blade with a dynamically variable shape, for the subsequent creation of an improved model of a wind turbine with increased efficiency. A distinctive feature is the use of nylon as a sail material.

Nylon has become one of the first synthetic fabrics in the world to be made from polyamide. In appearance, it is similar to silk — it has the same shine and smooth front surface. The fabric is strong and elastic; it is difficult to tear it. Nylon is more elastic, so it easily absorbs overloads caused by changes in wind speed values. Figure 1 illustrates an experimental sail made of nylon.

The main differences between nylon and polyester are:

1. Appearance and tactile sensations. Nylon is smooth to the touch and resembles silk. Polyester has a rough matte surface with a visible weave pattern.
2. Weight. A large nylon canvas weighs little. Polyester is also light, but it is larger than nylon.
3. Water resistance. The water-repellent properties of polyester are several times lower.



Figure 1. Experimental sail sample

According to the theory of aerodynamics, the following indicators influence the drag force and lift:

- a) dynamic pressure;
- b) area of the sail, m<sup>2</sup>;
- c) angle of installation of the sail relative to the wind direction;
- d) linear dimensions of the sail, its profile, the fullness of the belly, etc.;
- e) properties of the sail fabric, i.e. its smoothness, rigidity, ductility, density, etc.;
- f) angle of inclination of the sail.

Considering the shape of the sail, it should be noted its elongation, which is directly proportional to the height of the sail H and inversely proportional to the length of the middle chord of its profile l (Figure 2) [9].

For rectangular sails, it is equal to the ratio  $\frac{H}{l}$ . Also, the elongation is determined by dividing the height of the sail H by its average width for a number of sails, such as guari, triangular, gaff, etc. The average width can be calculated by dividing the area of the sail S by its height H:

$$\text{Elongation} = \frac{H}{S} = \frac{H^2}{S} \quad (1)$$

The fullness of the sail, i.e. the belly of the sail is directly proportional to the magnitude of the deflection arrow and inversely proportional to the length of the chord of the sail profile l:

$$\text{Fullness} = \frac{f}{l} \quad (2)$$

The influence of all these factors can be taken into account with some remarks when determining the aerodynamic force according to certain formulas. It is established that two identical sails (in shape, cut, fabric, etc.) differ only in area and work with the same angle of attack, in any winds form aerodynamic forces proportional in magnitude to the dynamic wind pressure and sail area.

Having expressed the factors specified in paragraphs c, d, g, e in terms of the coefficient C, the aerodynamic force generated by the flow of the sail is found through the following formula:

$$F = qSC = 0,0625V_k^2 SC \quad (3)$$

Where F is the aerodynamic force in kg, V<sub>k</sub> is the wind speed in m/s, S is the windage area in m<sup>2</sup>, C is the coefficient of aerodynamic force [7].

The characteristic of the aerodynamic qualities of the sail is the polar, which shows how the coefficient of lift varies depending on the coefficient of drag and angle of attack (Figure 3) [9].

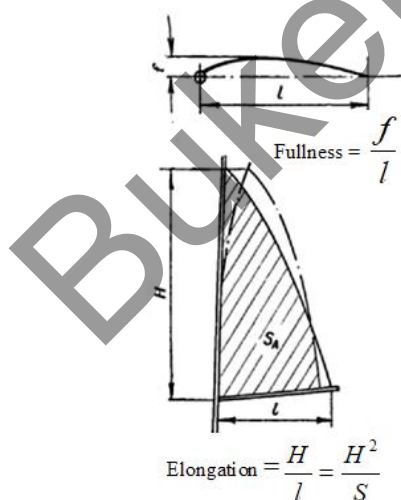

Figure 2. Puffiness and elongation of the sail

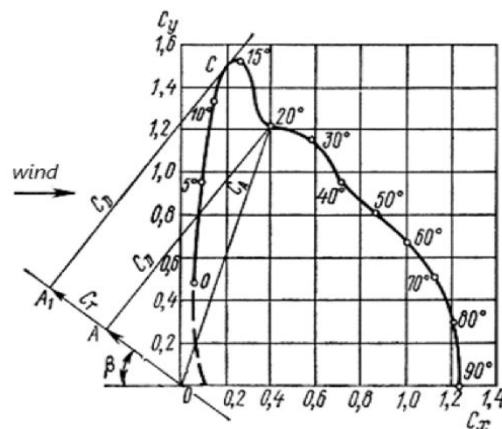

Figure 3. Polar of the sail

The coordinate axes show dimensionless coefficients Cy and Cx, so that this graph can be applied to a sail with any geometric data. The coefficients are calculated by dividing the magnitude of the measured force

by the dynamic wind pressure  $q$ , as well as by the windage area  $S$ , respectively, the coefficients will be obtained:

$$C_x, C_y \text{ or } C = \frac{X, Y \text{ or } F}{qS} \quad (4)$$

With a polar, it is possible to determine the lift and drag force values and their components — the thrust force. The sail polarity allows selecting the most favorable angle for setting the sails on a given course in relation to the wind, i.e., the pulling force is at its maximum value.

### Results and Discussion

The values of the lifting force obtained for a triangular sail blade with vertices angles  $\gamma$  ( $0^\circ$ ;  $30^\circ$ ;  $60^\circ$ ;  $90^\circ$ ) at a speed range from 3 to 12 m/s are represented by the dependence shown in Figure 4. Also, under these conditions, the drag forces were determined (Figure 4).

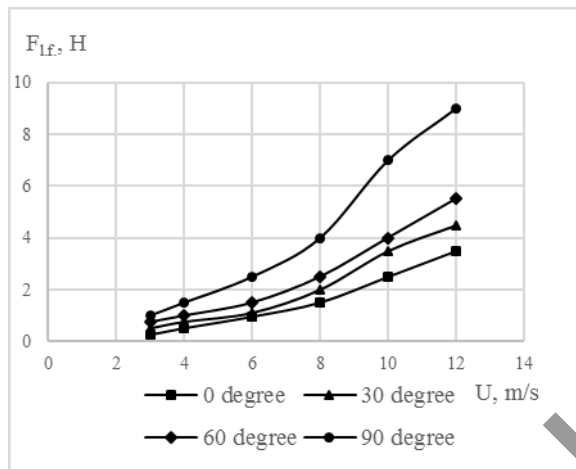

Figure 4. Graph of dependences of the lift forcing of the sail blade on the flow velocity at various angles  $\gamma$  of the apex of the triangular blade

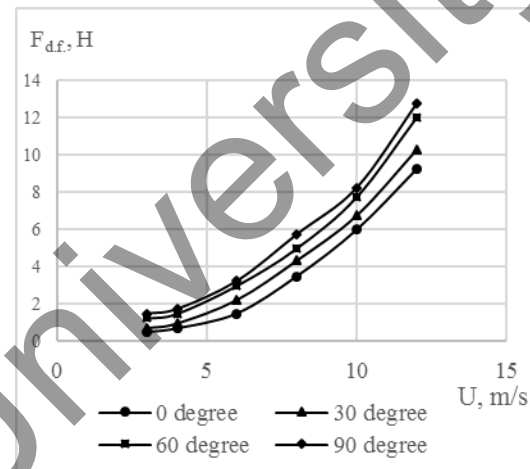

Figure 5. Graph of the dependences of the drag forces of the sail blades on the flow velocity at different angles  $\gamma$  of the apex of the triangular blade

From the obtained dependencies (Figures 4, 5), a proportional dependence of the blades' lift force and drag force on the flow velocity is visible. At the lowest wind speeds from 3 to 5 m/s, the appearance of lifting force is observed at values of about 2 N with a vertex angle of  $\gamma = 90^\circ$ , which proves the effectiveness of use for a range of low speeds. In a comparative analysis of the results obtained, it was found that the maximum lifting force has a sail blade with a vertex angle  $\gamma = 90^\circ$ .

Thus, a flexible sail blade with an apex angle  $\gamma = 90^\circ$  has optimal aerodynamic characteristics.

The dependence of the change in the drag coefficient on the dimensionless angle of attack  $\beta$  of the wind is constructed, under the condition when the flow velocity was 5 m/s (Figure 6).

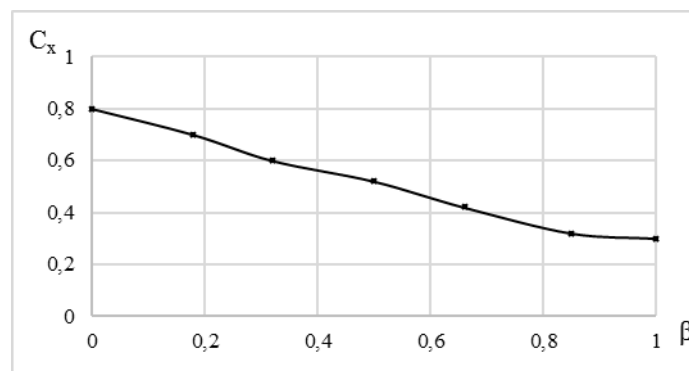

Figure 6. Dependence of the aerodynamic coefficient (drag) from  $\beta$

One can see from Figure 6, the drag coefficient decreases with increasing  $\beta$ , this phenomenon can be explained as follows: at the attack angle  $\beta = 0^{\circ}$ , the Middle area of the sail blade to the streamlined air flow will be maximum. Accordingly, when the air flows around the sail blade, the resistance force will be maximum. The sail blade will change position in relation to the stream with an increase in the attack angle. With an angular position change, the area of the middle cross-section of the blade begins to decrease relative to the incoming flow. With a decrease in the middle section of the blade, the drag force decreases, and the drag coefficient decreases accordingly.

The dependence of the change in the lift coefficient on the dimensionless angle of attack  $\beta$  of the wind is constructed, under the condition when the flow velocity was 5 m/s (Figure 7).

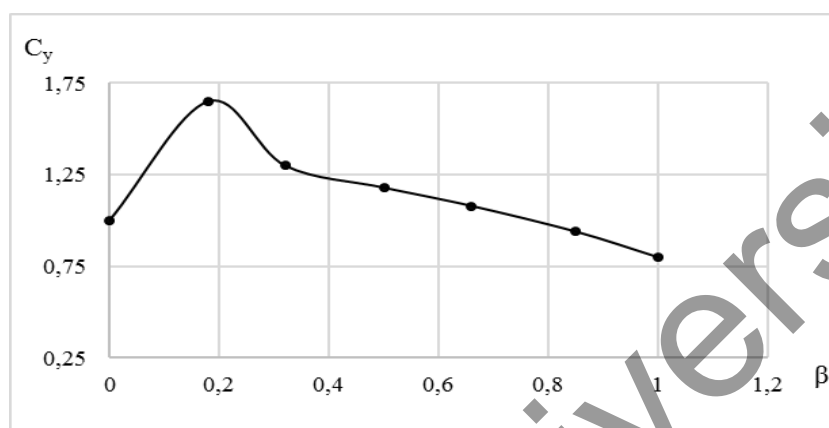

Figure 7. Dependence of the aerodynamic coefficient (lift) from  $\beta$

Figure 7 demonstrates that up to  $\beta = 15^{\circ}$ , the value of the lift coefficient increases to 1.75, after which a sharp decline is observed. The reason for this is that up to a certain value of the angle of attack, the fullness of the belly of the sail is zero, and the sail bends, thereby increasing the pressure.

With a further increase in  $\beta$ , the streamlined area of the sail will decrease, which entails a decrease in lift.

Figure 8 shows the sail blade polarities for an airflow velocity of 5 m/s.

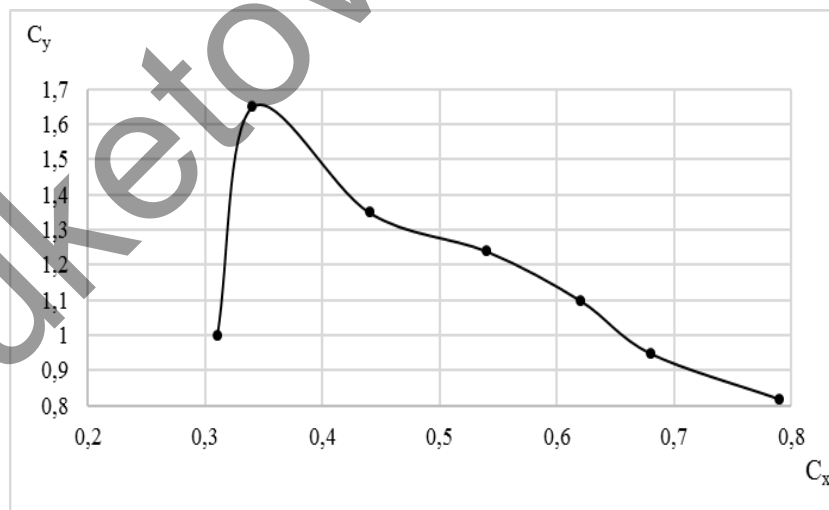

Figure 8. Sail blade polarities

Due to the fact that the ends of the triangular blade are regulated by a flexible attachment, thereby creating a dynamically changing shape of the blade surface, the drag coefficient of the sail of the authors of the work is greater than the sails, the ends of which are rigidly fixed.

Figures 9, 10 designate the dependences of the aerodynamic coefficients on  $n$  (the number of blades).

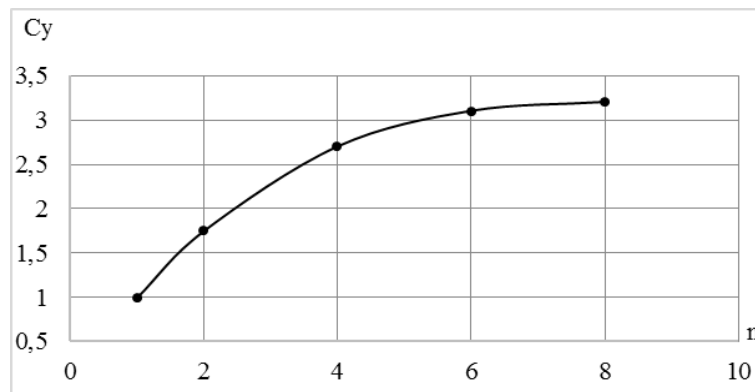

Figure 9. Dependence of the aerodynamic coefficient (lift) from n

From Figure 9, one can notice that the lift coefficient increases with an increase in n from 1 to 6. This phenomenon is observed, although the flow velocity, angle of attack, and area of the wind wheel do not change.

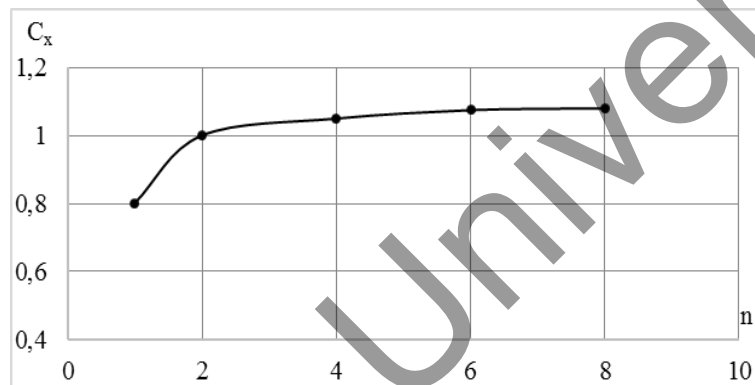

Figure 10. Dependence of the aerodynamic coefficient (drag) on n

Figure 10 represents that when the number of blades reaches 2, there is an intensive increase in the lift coefficient. When the number of blades is further increased to 8, there is a slight increase. Based on this, a further increase in the number of blades is not advisable, because the material consumption and the price of the wind turbine increases.

The task of a sailing wind wheel is to use all available power coming to the swept area. According to Bernoulli's law, when the flow velocity decreases, the pressure increases. As a result, we have increased pressure from the windward side of the wind wheel and discharge from the downwind side. It is the triggering of the energy of this pressure drop that quantifies the operation of the windmill.

From experimental data, it has been established that the optimal number of triangular blades for a wind power plant with sailing shovels is 6. Compared with winged wind turbines [10] for which the optimal number of blades is 3, in which the wind turbine has high performance, increasing the number of blades, a physical phenomenon is observed for them when the wind freely penetrates between the blades to the opposite side of the wind wheel — equalizing the pressure, resulting in reduced productivity. The error in the experiment was 4–5 %, which falls within the acceptable range.

### Conclusions

We investigated the aerodynamic coefficients of a sail blade and a wind wheel made of nylon materials. Compared with the results of work [11], where polyester was used as the material of the sail blade, the lifting force of nylon is 15–20 % higher.

During the study, the following optimal results were obtained:

- The aerodynamic forces of the sail blade depend on the flow velocity at different angles of the top. It is established that at  $\gamma = 90^\circ$  the triangular blade has the maximum values of aerodynamic forces, with a decrease in the angle to  $0^\circ$  there is a decrease, this is due to an increase in the area of resistance relative to the

air flow. This phenomenon can be explained by the fact that the drag force is directed against the speed of movement, its magnitude is proportional to the characteristic area of resistance. At the optimal angle  $\gamma = 90^\circ$  around the triangular blade, the occurrence of air vortices is minimal, thereby leading to the prevention of disruption of vortices from the ends of the triangular blade.

- With a decrease in the mid-section of the wind wheel, the aerodynamic forces decrease, and their coefficients decrease accordingly. This is due to the fact that the reverse process of reducing the airflow velocity and increasing pressure begin behind the midsection of the sail blade. At the same time, increased pressure is created on the front side of the body, and reduced pressure is created on the backside. The boundary layer flowing around the sail blade, having passed its midsection, breaks away from the sail and, under the influence of reduced pressure behind the body, changes the direction of movement, forming a vortex. This happens both at the upper and lower points of the sail;

- The optimal number of triangular blades for a wind power plant with sailing shovels is 6.

## References

- 1 Патент РФ № 2625080 C1. Ветроэнергетическая установка. Оpubл. // Бюлл. — 2017 / Н.П. Дядченко.
- 2 Gandhi A.R. Design and development of sail type wind turbine with solar panel / A.R. Gandhi, A. Ravinthiran, K. Palanikumar // *Materials Today: Proceedings*, 2021. — Vol. 46. — Part 9. — P. 3989–3992. <https://doi.org/10.1016/j.matpr.2021.02.527>
- 3 Ghosh P. Experimental Investigations on Sail Type Wind-Turbines / P. Ghosh, M.A. Kamoji, A.W. Date, S.V. Prabhu // *Wind Engineering*, 2009. — Vol 33, Iss. 4. <https://doi.org/10.1260/030952409789685717>
- 4 Ignazio M.V. Sail aerodynamics: Understanding pressure distributions on upwind sails / M.V., Ignazio, G.J.F. Richard. // *Experimental Thermal and Fluid Science*, 2011. — Vol. 35, Iss. 8. — P. 1497–1504. <https://doi.org/10.1016/j.expthermflusci.2011.06.009>
- 5 He J. Research on sail aerodynamics performance and sail-assisted ship stability / J. He, Y.Hu, J. Juan Tang, Sh. Xue // *Journal of Wind Engineering and Industrial Aerodynamics*, 2015. — Vol. 146. — P. 81–89.
- 6 Jean-Baptiste R.G.S. Recent Advances in Numerical and Experimental Downwind Sail Aerodynamics / R.G.S. Jean-Baptiste, A. Abel, M.V. Ignazio // *Journal of Sailing Technology*, 2019. — Vol. 4 (01). — P. 45–65. <https://doi.org/10.5957/jst.2019.4.1.45>
- 7 Tanasheva N.K. Studying the dependence of the aerodynamic characteristics of rotating cylinders on the rake angle of air flow / N.K. Tanasheva, N.N. Shuyushbayeva, E.K. Mussenova // *Technical Physics Letters*, 2019. — Vol. 44 (9). — P. 787–789.
- 8 Tanasheva N.K. The study of the aerodynamic coefficients of rotating cylinders/ N.K. Tanasheva, A.N. Dyusembaeva, B.R. Nussupbekov, L.L. Min'kov, Zh.G. Nurgalieva, K.K. Sadenova // *Bulletin of the Karaganda University, Physics Series*, 2019. — Vol. 2 (94). — P. 108–113.
- 9 Мархай Ч. Теория плавания под парусами / Ч. Мархай. — М., 1970. — 411 с.
- 10 Adeyeye K.A. The effect of the number of blades on the efficiency of a wind turbine / K.A. Adeyeye, N. Ljumba, J. Colton // *IOP Conference Series: Earth Environmental Science*, 2021.
- 11 Сакипова С.Е. Анализ аэродинамических характеристик и эффективности двух макетов ветротурбины парусного типа / С.Е. Сакипова, Ж.Т. Камбарова, М.М. Тургунов, А.М. Алькенова // *Вестн. Караганд. ун-та. Сер. Физика*. — 2016. — № 1(81) — С. 62–68.

А.Ж. Тлеубергенова, Н.К. Танашева, К.М. Шаймерденова,  
Л.Л. Миньков, А.Н. Дюсембаева, С.Ж. Узбергенова

## Желкенді қалақшаның аэродинамикалық параметрлерін зерттеу

Мақалада әртүрлі параметрлердегі үшбұрышты желкенді қалақшаның аэродинамикалық сипаттамалары зерттелген. Осы мақсатта динамикалық өзгеретін беті бар үшбұрышты желкенді қалақша жасалды. Ауа ағынының жылдамдығы 3-тен 12 м/с-қа дейін өзгерді. Үшбұрышты қалақша шыңының әртүрлі бұрыштары кезінде желкенді қалақшаның аэродинамикалық күштерінің ағынның жылдамдығына тәуелділігі зерттелді. Тәжірибелер шыңдардың әртүрлі бұрыштарында жүргізілді:  $0^\circ$ ;  $30^\circ$ ;  $60^\circ$ ;  $90^\circ$ . Шыңның бұрышы  $\gamma=90^\circ$  кезінде үшбұрышты желкенді қалақша оңтайлы аэродинамикалық параметрлерге ие болатыны айқындалды. Аэродинамикалық коэффициенттердің шабуыл бұрышының өлшемсіз тәуелділігі алынған. Динамикалық өзгеретін бет пішіні бар қалақшалы жел турбинасы үшін қалақшаның оңтайлы саны  $n=6$  екендігі анықталды. Шабуылдың  $\alpha=0^\circ$  бұрышы кезінде желдөңгалағының миделдік ауданының максималды мәні ағылатын ауа ағынына  $\alpha$  шабуылы артқанда маңдайлық кедергі коэффициенті мәнінің төмендеуіне әкеледі. Желкенді қалақшаның ауа ағынының жылдамдығынан  $\alpha$ -ның өзгеруі бойынша тәжірибе нәтижелеріне талдау жүргізілген. Қалақшаның орны өзгерген сайын маңдайлық кедергі ауа ағынына қатысты өзгереді. Желдөңгелегі  $\alpha$  мәнінің жоғарылауымен ауа ағынына қатысты өз орнын өзгертеді. Бұл жағдайда бұрыштың орны өзгерген кезде қозғалатын ағынға қатысты желдөңгалағының мидель қимасының азаюы байқалады.

Жел доңғалағының мидель кимасының төмендеуімен маңдайлық кедергі күші төмендей бастайды, сәйкесінше маңдайлық кедергі коэффициенті төмендейді. Осылайша, желкеннің ық жағы және жел жак беттеріндегі қысымының өзгеруінің жалпы нәтижесін жел бағытының перпендикуляр сызығының кейбір бұрыштарына бағытталған, бір тең әсер ететін аэродинамикалық күш ұсынылуы мүмкін.

*Кілт сөздер:* желкен, желэнергетикалық қондырғысы, ағынның жылдамдығы, аэродинамикалық күш, Т-1-М аэродинамикалық құбыры, шабуыл бұрышы.

А.Ж. Тлеубергенова, Н.К. Танашева, К.М. Шаймерденова,  
Л.Л. Миньков, А.Н. Дюсембаева, С.Ж. Узбергенова

## Исследование аэродинамических параметров парусной лопасти

В статье изучены аэродинамические характеристики треугольной парусной лопасти различных параметров. Для данной цели была изготовлена треугольная парусная лопасть с динамически изменяемой формой поверхности. Скорость воздушного потока варьировалась, начиная 3 до 12 м/с. Была исследована зависимость аэродинамических сил парусной лопасти с разными углами вершинами от скорости потока. Эксперименты проведены при различных углах вершинах:  $0^{\circ}$ ;  $30^{\circ}$ ;  $60^{\circ}$ ;  $90^{\circ}$ . В результате эксперимента выявлено, что при угле вершине  $\gamma=90^{\circ}$  треугольная парусная лопасть обладает оптимальными аэродинамическими параметрами. Получены зависимости аэродинамических коэффициентов от безразмерного угла атаки. Обнаружено, что для ветротурбины с парусными лопастями оптимальным числом лопастей является  $n=6$ . Установлено, что при угле атаки  $\alpha=0^{\circ}$  максимальное значение миделево площадь ветроколеса обтекаемому воздушному потоку введет собою к убыванию значения коэффициента лобового сопротивления с увеличением атаки  $\alpha$ . Проведен анализ результатов эксперимента по изменению  $\alpha$  от скорости воздушного потока парусной лопасти. При изменении положения лопасти лобовое сопротивление меняется относительно воздушного потока. Ветроколесо изменяет свое положение относительно воздушного потока, с увеличением значения  $\alpha$ . При этом наблюдается уменьшение площади миделево сечения ветроколеса относительно к набегающему потоку при изменении углового положения. С уменьшением миделево сечения ветроколеса сила лобового сопротивления начинает убавляться, соответственно снижается коэффициент лобового сопротивления. Таким образом, суммарный результат изменения давлений на подветренной и наветренной поверхностях паруса можно представить в виде одной равнодействующей аэродинамической силы, направленной под некоторым углом к линии, перпендикулярной к направлению ветра.

*Ключевые слова:* парус, ветроэнергетическая установка, скорость потока, аэродинамическая сила, аэродинамическая труба Т-1-М, угол атаки.

## References

- 1 Dyadchenko, N.P. (2017). Patent Rossiiskoi Federatsii № 2625080 C1 [Patent of Russian Federation No. 2625080 C1] [in Russian].
- 2 Ghandi, A.R., Ravinthiran, A., & Palanikumar, K. (2021). Design and development of sail type wind turbine with solar panel. *Materials Today: Proceedings*, 46(9), 3989–3992. <https://doi.org/10.1016/j.matpr.2021.02.527>
- 3 Ghosh, P., Kamoji, M.A., Date, A.W., & Prabhu, S.V. (2009). Experimental Investigations on Sail Type Wind-Turbines. *Wind Engineering*, 33 (4). <https://doi.org/10.1260/030952409789685717>
- 4 Ignazio, M.V., & Richard, G.J.F. (2011). Sail aerodynamics: Understanding pressure distributions on upwind sails. *Experimental Thermal and Fluid Science*, 35(8), 1497–1504. <https://doi.org/10.1016/j.expthermflusci.2011.06.009>
- 5 He, J., Hu, Y., Tang, J.J., & Xue, Sh. (2015). Research on sail aerodynamics performance and sail-assisted ship stability. *Journal of Wind Engineering and Industrial Aerodynamics*, 146, 81–89.
- 6 Jean-Baptiste, R.G.S., Abel, A., & Ignazio, M.V. (2019). Recent Advances in Numerical and Experimental Downwind Sail Aerodynamics. *Journal of Sailing Technology*, 4 (01), 45–65. <https://doi.org/10.5957/jst.2019.4.1.45>
- 7 Tanasheva, N.K., Shuyushbayeva, N.N., & Mussenova, E.K (2018). Studying the dependence of the aerodynamic characteristics of rotating cylinders on the rake angle of air flow. *Technical Physics Letters*, 44 (9), 787–789.
- 8 Tanasheva, N.K., Dyusembaeva, A.N., Nussupbekov, B.R., Min'kov, L.L., Nurgalieva, Zh.G., & Sadenova K.K. (2019). The study of the aerodynamic coefficients of rotating cylinders. *Bulletin of the Karaganda of University-Physics*, 2(94), 108–113.
- 9 Markhai, Ch. (1970). Teoriia plavaniia pod parusami [Theory of sailing]. Moscow [in Russian].
- 10 Adeyeye K.A., Ljumba N., & Colton J. (2021). The effect of the number of blades on the efficiency of a wind turbine. IOP Conference Series: Earth Environmental Science.
- 11 Sakipova, S.E., Kambarova, Zh.T., Turgunov, M.M., & Alkenova, A.M. (2016). Analiz aerodinamicheskikh kharakteristik i effektivnosti dvukh maketov vetroturbiny parusnogo tipa [Analysis of aerodynamic characteristics and efficiency of two models of a sailing-type wind turbine]. *Vestnik Karagandinskogo universiteta. Seriya Fizika — Bulletin of the Karaganda of University-Physics*, 1(81), 62–68 [in Russian].