

S. Katsyv¹, V. Kukharchuk¹, V. Kucheruk², P. Kulakov², M. Gribov³

¹Vinnitsia National Technical University, Vinnitsia, Ukraine;

²Uman National University of Horticulture, Uman, Ukraine;

Vinnitsia National Agrarian University, Vinnitsia, Ukraine;

³National Academy of Internal Affairs, Kyiv, Ukraine.

(E-mail: vladimir.kucheruk@gmail.com)

Nonstandard analysis in electrical engineering. The analysis of the direct current circles with ideal reactive elements.

The article proposes the use of ideas and methods of non-standard analysis in the field of theoretical electronics. The article shows that the analysis of DC circuits, including ideal inductances and capacitances, by standard methods of theoretical electrical engineering is too complicated or almost impossible. To solve this problem, it is proposed to extend the methods of non-standard analysis by the tasks of analyzing electrical circuits with ideal reactive elements. The authors have defined a class of non-standard electrotechnical problems aimed at the analysis of DC electrical circuits, including ideal reactive elements — ideal inductances and capacitances. It is shown that the solution of the selected class of problems by standard methods of theoretical electrical engineering is too difficult or almost impossible. It is proposed to extend the methods of non-standard analysis by the tasks of analyzing electrical circuits with ideal reactive elements. The obtained advantages of this approach are confirmed by examples of calculations of electrical circuits with inductances and capacitances, as well as magnetic circuits.

Keywords: infinitesimal number, infinitude, hyperreal number, unconventional number, ideal reactive element.

Introduction

While solving diverse scientific or technical problems the researcher occasionally faces the necessity of revealing such uncertainties as $\frac{0}{0}$ and $\frac{\infty}{\infty}$. Herewith the use of classical methods, for instance, the rules of Cauchy or L'Hôpital often causes certain difficulties.

It is curious that exactly the ideas of nonstandard analysis (i.e. the direct use of infinitesimal numbers) were the base, on which Leibnitz and Newton intuitively built the principles of differential and integral calculations. However, later in Cauchy's works and in the works of other mathematicians, infinitesimal numbers were "left out" [1-5]. Instead, in the basis of mathematic apparatus of differential and integral calculation numerical and functional sequences and limit correlations of values were laid. That increased the axiomatic rigor of mathematical apparatus, but unfortunately complicated the way of solving a certain kind of problems.

The revival of the ideas of nonstandard analysis took place in 1960-s, when A. Robinson suggested a new axiomatics of math analysis, which bases on the multitude of hyperreal numbers, that contains not only so called reference numbers (common numbers), but also the nonstandard numbers (infinitesimal numbers, infinitudes and their combinations with common numbers) [6-8]. Methods of nonstandard analysis are also being developed at the present time and are used in various fields of science [9-12]. In this article, we will consider the use of nonstandard analysis in electrical engineering. Of interest is the use of nonstandard analysis methods in the problems of identifying the internal parameters of electrical motors, which in many cases cannot be solved by traditional methods [13-18].

For direct current circles, we use diverse unified methods of calculation based on the Ohm's and Kirchhoff's laws. At the same time, there exists a certain kind of related problems, for which the direct use of these unified methods is practically impossible. This concerns the calculation of the direct current circles with ideal reactive elements. The complexity of the calculations in such circles is that on the direct current the induction resistance ($x_L = \omega L$) tends to zero, and the ideal capacity ($x_C = \frac{1}{\omega C}$) resistance tends to infinity.

Generally, such problems are solved with simultaneous use of the energy characteristics of inductances and capacities alongside with electrical engineering laws, which considerably complicates the analysis of such circuits, especially in complex schemes. That explains the topicality of the math apparatus of nonstandard analysis which will enable to use familiar unified methods for calculating such circles.

The next unit will review the main principles of non-standard analysis necessary for the solution of the above mentioned electrotechnical problems, this mathematic apparatus is considered in [19-20].

Basic principles of nonstandard analysis

Let \mathbf{R} be an ordered set of real numbers. Number α will be called an infinitesimal number when and only when

$$\forall r \in \mathbf{R} (\alpha < r). \quad (1)$$

The number $\beta = \frac{1}{\alpha}$ will be called infinitude. In this case, it may be transcribed as

$$\forall r \in \mathbf{R} (\beta > r). \quad (2)$$

All algebraic operations (addition, subtraction, multiplication, division, exponentiation, etc.) and theorems (theorems of commutation and association, etc.) may be applied to infinitesimal and infinitude numbers.

Infinitesimal numbers and infinitudes of diverse order will be distinguished as follows:

- $\alpha > \alpha^2 > \alpha^3 > \alpha^k$ — infinitesimal numbers of first, second, third, k-th order;
- $\beta < \beta^2 < \beta^3 < \beta^k$ — infinitudes of first, second, third, k -th order.

Together with real numbers $r \in \mathbf{R}$ infinitesimal numbers and infinitudes make an ordered set of hyperreal numbers ${}^*\mathbf{R}$. Real numbers $r \in \mathbf{R}$ are commonly called standard or Archimedean numbers unlike imaginary (non-Archimedean) numbers ${}^*r \in {}^*\mathbf{R}$.

Each imaginary number has a standard part

$${}^*r = r \pm \alpha, \quad (3)$$

that is

$$r = \text{st}({}^*r), \quad (4)$$

in other words, a real number is a standard part of a certain imaginary number (obviously, there can be an infinite set of those).

Two real numbers a and b are called equal when and only when:

$$a - b = 0. \quad (5)$$

Two imaginary numbers *a and *b are called equivalent (or infinitely close to each other when and only when:

$${}^*a - {}^*b \approx \alpha. \quad (6)$$

The marking “ \approx ” will stand for the equivalency of two imaginary numbers. For real numbers m and n we will denote certain correlations that appear from (1-6):

$$\frac{1}{\alpha^k} = \beta^k, \quad \frac{m}{\alpha} = m\beta, \quad \frac{m}{\alpha^k} = m\beta^k, \quad (7)$$

$$\frac{m\alpha}{n\alpha} = \frac{m}{n}, \quad \frac{m\alpha}{n} = \frac{m}{n}\alpha, \quad \frac{m}{n\alpha} = \frac{m}{n}\beta, \quad (8)$$

$$m\alpha + n \approx n, \quad m\beta + n \approx m\beta, \quad m\alpha^k + n \approx n, \quad m\beta^k + n \approx m\beta^k, \quad (9)$$

$$\sin \alpha \approx \alpha, \quad \cos \alpha \approx 1. \quad (10)$$

We will give a few examples of using these methods in a mathematic analysis. For instance, let us find the first derivative of the function $y = x^3$. For that purpose, we will input a substitution $dx = \alpha$.

$$\frac{dy}{dx} = \frac{(x + \alpha)^3 - x^3}{\alpha} = \frac{x^3 + 3x^2\alpha + 3x\alpha^2 + \alpha^3 - x^3}{\alpha} = 3x^2 + 3x\alpha + \alpha^2 \approx 3x^2. \quad (11)$$

For $y = \sin x$ we will get

$$\begin{aligned} \frac{dy}{dx} &= \frac{\sin(x + \alpha) - \sin x}{\alpha} = \frac{\sin x \cdot \cos \alpha + \sin \alpha \cdot \cos x - \sin x}{\alpha} \approx \\ &\approx \frac{\sin x \cdot 1 + \alpha \cdot \cos x - \sin x}{\alpha} \approx \cos x. \end{aligned} \quad (12)$$

Let $y = \cos x$. Then

$$\begin{aligned} \frac{dy}{dx} &= \frac{\cos(x + \alpha) - \cos x}{\alpha} = \frac{\cos x \cdot \cos \alpha - \sin x \cdot \sin \alpha - \cos x}{\alpha} \approx \\ &\approx \frac{\cos x \cdot 1 - \sin x \cdot \alpha - \cos x}{\alpha} \approx -\sin x. \end{aligned} \quad (13)$$

It is quite natural, that not only a multitude of real numbers might have such a nonstandard structure, but also the multitude of imaginary numbers can, i.e. the complex number plane.

Then, analogically to (9) we may transcribe

$$m\alpha + jn \approx jn, \quad m\beta + jn \approx m\beta, \quad m + jn\alpha \approx m, \quad m + jn\beta \approx jn\beta. \quad (14)$$

Besides, the problems of classical analysis of transitive processes call for the direct use of the real number 0 and the infinite value ∞ . That is why, we will try to formulate their nonstandard interpretation.

Real number 0 in the nonstandard analysis may be considered as infinitesimal number of infinite order, i.e. $0 \approx \alpha^\beta$. That is why

$$\frac{0}{\alpha} \approx 0, \quad 0 \cdot \beta \approx 0, \quad e^{-\beta \cdot 0} \approx 1, \quad e^{-\alpha} \approx 1. \quad (15)$$

Infinite value ∞ in non-standard analysis may be introduced as infinitude of infinite order, i.e. $\infty \approx \beta^\beta$. That is why

$$\frac{\infty}{\beta} \approx \infty, \quad \infty \cdot \alpha \approx \infty, \quad e^{-\infty \cdot \alpha} \approx \alpha, \quad e^{-\beta} \approx \alpha. \quad (16)$$

Before going on to use above given expressions for solving diverse applied problems, it is suffice to notice, that there are no general rules for parameter selection, which can be advisably equated to an infinitesimal (or infinitude) number. The researcher depending on the context of the peculiar problem makes this selection. Herewith, one must consider that in case of necessity to substitute for a few different options of one problem with infinitesimals, defining correlations between these numbers is quite an uneasy task to do and may require additional researches.

In the next subparagraph, we suggest considering the ways of using the methods of nonstandard analysis for analyzing the direct current circuits with ideal reactive elements.

Viewing the direct current circuit as a sinusoid alternating current circuit, the frequency of which equals to zero, a symbolic method may be used for solving such problems, given $\omega = \alpha$.

Let us consider the typical examples of such problems.

The analysis of direct current electrical circuits with ideal inductances.

Taking $\omega = \alpha$ for impedance of inductance it may be transcribed as follows:

$$\underline{Z}_L \approx j\alpha L. \quad (17)$$

Example 1. Determine the currents in inductances L_1, L_2 in the direct current circuit (Fig. 1).

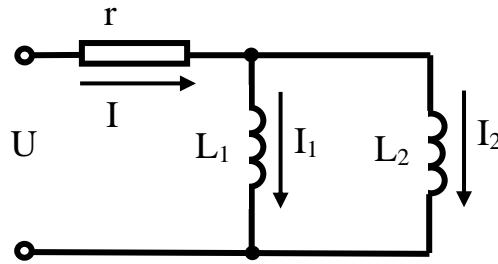

Figure 1. Direct current circuit

Scheme options: $U = 30 \text{ V}$, $r = 10 \text{ } \Omega$, $L_1 = 0.2 \text{ H}$, $L_2 = 0.1 \text{ H}$. At first, it seems that the currents in inductances are the same $I_1 = I_2 = \frac{I}{2} = \frac{U}{2r} = 1.5$. As far as the resistances of these branches on the direct current amount to zero. However, let us try to solve this problem using infinitesimals.

The whole impedance of the circuit equals to

$$\underline{Z}_{in} \approx r + \frac{(j\alpha L_1)(j\alpha L_2)}{j\alpha L_1 + j\alpha L_2} = r + \frac{j^2 \alpha^2 L_1 L_2}{j\alpha(L_1 + L_2)} = r + j\alpha \frac{L_1 L_2}{(L_1 + L_2)}, \quad (18)$$

and according to (14) $\underline{Z}_{in} \approx r$. Hence, $\underline{I} = \frac{U}{r} = 3$ and the inductance voltage is

$$\underline{U}_L = j\alpha \frac{L_1 L_2}{(L_1 + L_2)} \underline{I} = \frac{U}{r} j\alpha \frac{L_1 L_2}{(L_1 + L_2)}, \quad (19)$$

while the currents in the branches are:

$$\underline{I}_1 = \frac{\underline{U}_L}{j\alpha L_1} = \frac{U L_2}{(L_1 + L_2)r} = 1 \text{ A}, \quad \underline{I}_2 = \frac{\underline{U}_L}{j\alpha L_2} = \frac{U L_1}{(L_1 + L_2)r} = 2 \text{ A}. \quad (20)$$

It shows that the total current I at the inlet to the circuit is split between inductances is no way the same, but inversely to their meanings.

Even more curious is the case, where in this circuit there is a magnetic coupling between both inductive coils.

Example 2. If both coils are switched on coordinately (Fig. 2), the system of equations according to Kirchhoff laws will look as follows:

$$\underline{I} - \underline{I}_1 - \underline{I}_2 = 0, \quad (21)$$

$$\underline{I}r + \underline{I}_1 j\alpha L_1 + \underline{I}_2 j\alpha M = U, \quad (22)$$

$$\underline{I}_1 j\alpha L_1 + \underline{I}_2 j\alpha M = \underline{I}_2 j\alpha L_2 + \underline{I}_1 j\alpha M. \quad (23)$$

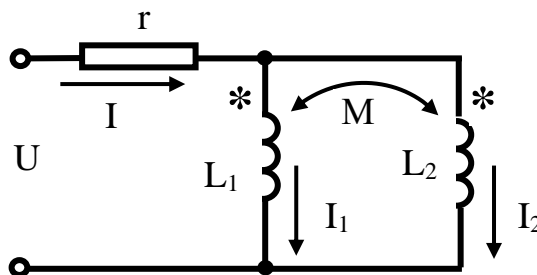

Figure 2. Circuit with magnetic coupling between both inductive coils

For the other equation of this system, we will carry out the equivalent conversions according to (10):

$$\underline{I}r + \underline{I}_1 j\alpha L_1 + \underline{I}_2 j\alpha M \approx \underline{I}r = U. \quad (24)$$

Hence $\underline{I} = \frac{U}{r} = 3$ A. In this way, we have obtained a new system of equations:

$$\frac{U}{r} - \underline{I}_1 - \underline{I}_2 = 0, \quad (25)$$

$$\underline{I}_1 j\alpha L_1 + \underline{I}_2 j\alpha M = \underline{I}_2 j\alpha L_2 + \underline{I}_1 j\alpha M. \quad (26)$$

Let us determine current \underline{I}_1 from the first equation and substitute it into the second equation:

$$\underline{I}_1 = \frac{U}{r} - \underline{I}_2, \quad (27)$$

$$\left(\frac{U}{r} - \underline{I}_2\right) j\alpha L_1 + \underline{I}_2 j\alpha M = \underline{I}_2 j\alpha L_2 + \left(\frac{U}{r} - \underline{I}_2\right) j\alpha M. \quad (28)$$

Hence,

$$\frac{U}{r} j\alpha L_1 - \underline{I}_2 j\alpha L_1 + \underline{I}_2 j\alpha M = \underline{I}_2 j\alpha L_2 + \frac{U}{r} j\alpha M - \underline{I}_2 j\alpha M, \quad (29)$$

$$\frac{U}{r} (j\alpha L_1 - j\alpha M) = \underline{I}_2 (j\alpha L_1 + j\alpha L_2 - 2j\alpha M), \quad (30)$$

$$\underline{I}_2 = \frac{\frac{U}{r} (j\alpha L_1 - j\alpha M)}{(j\alpha L_1 + j\alpha L_2 - 2j\alpha M)} = \frac{U(L_1 - M)}{r(L_1 + L_2 - 2M)}, \quad (31)$$

$$\underline{I}_1 = \frac{U}{r} - \underline{I}_2 = \frac{U}{r} - \frac{U(L_1 - M)}{r(L_1 + L_2 - 2M)} = \frac{U(L_2 - M)}{r(L_1 + L_2 - 2M)}. \quad (32)$$

We will perform numerical calculations for three typical cases of correlation between self-inductance L_1 , L_2 and mutual inductance M (values L_1 , L_2 are the same as those in the previous example):

1. Let $M = 0.08$ H, i.e. $M < L_2$. Hence, $\underline{I}_1 = 0.429$ A, and $\underline{I}_2 = 2.571$ A. This case does not differ significantly from the previous example.
2. Let take $M = 0.1$ H, i.e. $M = L_2$. In this case, the whole current flows in the second coil ($\underline{I}_2 = 3$ A), while in the first one it disappears ($\underline{I}_1 = 0$ A).

The most curious is the third case $M = 0.14$ H, when $L_2 < M < \sqrt{L_1 L_2}$. Here we observe a very distinct so-called “false capacity effect”, when the currents in each coil surpass the input current ($\underline{I}_1 = -6$ A, $\underline{I}_2 = 9$ A), and more to that, in the first coil the current changes its direction.

Suffice it to notice, that this problem is very hard to solve without methods of nonstandard analysis, and for the next problem it is almost impossible.

Example 3. In the direct current circuit (Fig. 3) determine the currents in all of the branches.

Scheme parameters: $U = 100$ V, $r = 10$ Ω , $L_1 = 0.2$ H, $L_2 = 0.15$ H, $L_3 = 0.1$ H, $L_4 = 0.05$ H, $L_5 = 0.025$ H.

Let us carry out this calculation with a loop current method.

By analogy to the previous examples, it is obvious that the input impedance of this circuit also equals to resistor impedance, i.e. $\underline{Z}_{in} \approx r$.

Hence, the loop current of the first loop is known:

$$\underline{I}_{11} = \frac{U}{r} = 10$$
 A, (33)

and the equation system will look as follows

$$\underline{I}_{11}\underline{Z}_{21} + \underline{I}_{22}\underline{Z}_{22} + \underline{I}_{33}\underline{Z}_{23} = 0, \quad (34)$$

$$\underline{I}_{11}\underline{Z}_{31} + \underline{I}_{22}\underline{Z}_{32} + \underline{I}_{33}\underline{Z}_{33} = 0. \quad (35)$$

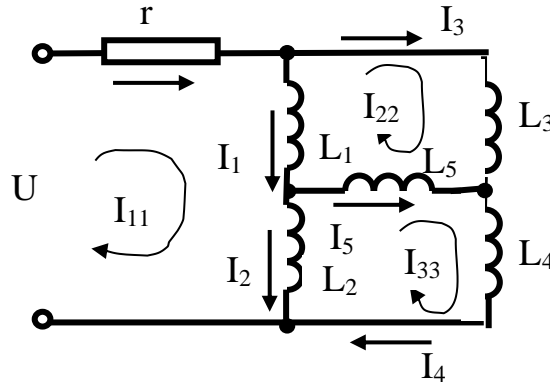

Figure 3. Circuit with detection of currents in all branches

Substituting expressions for the first loop current and as well as for loop and joint impedances, we will get

$$\frac{U}{r}(-j\alpha L_1) + \underline{I}_{22}(j\alpha L_1 + j\alpha L_3 + j\alpha L_5) + \underline{I}_{33}(-j\alpha L_5) = 0, \quad (36)$$

$$\frac{U}{r}(-j\alpha L_2) + \underline{I}_{22}(-j\alpha L_5) + \underline{I}_{33}(j\alpha L_2 + j\alpha L_4 + j\alpha L_5) = 0. \quad (37)$$

Let us define the third loop current from the first equation and substitute it into the second equation.

$$\begin{aligned} \underline{I}_{33} &= \frac{\frac{U}{r}(-j\alpha L_1) + \underline{I}_{22}(j\alpha L_1 + j\alpha L_3 + j\alpha L_5)}{j\alpha L_5} = \\ &= \frac{\underline{I}_{22}(L_1 + L_3 + L_5) - \frac{U}{r}L_1}{L_5} = \underline{I}_{22} \frac{L_1 + L_3 + L_5}{L_5} - \frac{UL_1}{rL_5}, \end{aligned} \quad (38)$$

$$\begin{aligned} &\frac{U}{r}(-j\alpha L_2) + \underline{I}_{22}(-j\alpha L_5) + \left(\underline{I}_{22} \frac{L_1 + L_3 + L_5}{L_5} - \frac{UL_1}{rL_5} \right) (j\alpha L_2 + j\alpha L_4 + j\alpha L_5) = \\ &= \underline{I}_{22} \left[\frac{L_1 + L_3 + L_5}{L_5} (j\alpha L_2 + j\alpha L_4 + j\alpha L_5) - j\alpha L_5 \right] - \frac{UL_1}{rL_5} (j\alpha L_2 + j\alpha L_4 + j\alpha L_5) - \frac{U}{r} j\alpha L_2 = 0 \end{aligned} \quad (39)$$

Hence, we determine loop currents

$$\begin{aligned} \underline{I}_{22} &= \frac{\frac{UL_1}{rL_5} (j\alpha L_2 + j\alpha L_4 + j\alpha L_5) + \frac{U}{r} j\alpha L_2}{\frac{L_1 + L_3 + L_5}{L_5} (j\alpha L_2 + j\alpha L_4 + j\alpha L_5) - j\alpha L_5} = \\ &= \frac{\frac{UL_1}{rL_5} (L_2 + L_4 + L_5) + \frac{U}{r} L_2}{\frac{L_1 + L_3 + L_5}{L_5} (L_2 + L_4 + L_5) - L_5} = 6.724 \text{ A}, \end{aligned} \quad (40)$$

$$\underline{I}_{33} = \frac{\frac{UL_1}{rL_5}(L_2 + L_4 + L_5) + \frac{U}{r}L_2}{\frac{L_1 + L_3 + L_5}{L_5}(L_2 + L_4 + L_5) - L_5} \frac{L_1 + L_3 + L_5}{L_5} - \frac{UL_1}{rL_5} = 7.414 \text{ A.} \quad (41)$$

Henceforward it is easy to determine currents in the branches:

$$\underline{I}_1 = \underline{I}_{11} - \underline{I}_{22} = 3.276 \text{ A}, \quad \underline{I}_2 = \underline{I}_{11} - \underline{I}_{33} = 2.586 \text{ A}, \quad (42)$$

$$\underline{I}_3 = \underline{I}_{22} = 6.724 \text{ A}, \quad \underline{I}_4 = \underline{I}_{33} = 7.414 \text{ A}, \quad \underline{I}_5 = \underline{I}_{33} - \underline{I}_{22} = 0.69 \text{ A}. \quad (43)$$

Suffice it to note, that the usage of ideas of nonstandard analysis allows using any standard methods of electrical circuit calculation.

Let us now consider ideal capacity circuits.

Analysis of electrical direct current circuits of ideal capacities

It is obvious, in such cases for capacity complex impedance we may write down

$$\underline{Z}_C \approx \frac{1}{j\alpha C}. \quad (44)$$

Example 4. Define voltages on the capacities C_1 , C_2 in the direct current circuit (Fig. 4).

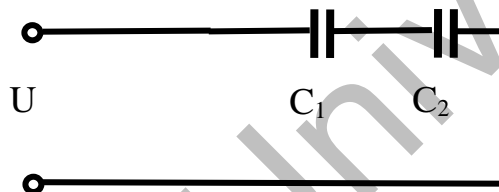

Figure 4. Circuit with capacitances

Let us consider this circuit as a sinusoidal alternating current circuit with $\omega = \alpha$ angular frequency.

Full circuit complex impedance is

$$\underline{Z}_{in} \approx \frac{1}{j\alpha C_1} + \frac{1}{j\alpha C_2} = \frac{j\alpha C_1 + j\alpha C_2}{(j\alpha C_1)(j\alpha C_2)} = \frac{C_1 + C_2}{j\alpha C_1 C_2}, \quad (45)$$

hence, the current flowing through it is

$$\underline{I} = \frac{U}{\underline{Z}_{in}} = \frac{Uj\alpha C_1 C_2}{C_1 + C_2}, \quad (46)$$

whence the voltages on capacities correspondently equate to

$$U_{C_1} = \underline{I} \frac{1}{j\alpha C_1} = \frac{UC_2}{C_1 + C_2}, \quad U_{C_2} = \underline{I} \frac{1}{j\alpha C_2} = \frac{UC_1}{C_1 + C_2}. \quad (47)$$

Example 5. In direct current circuit (Fig. 5) define voltages on all capacities. Circuit parameters: $U = 100 \text{ V}$, $C_1 = 200 \mu\text{F}$, $C_2 = 150 \mu\text{F}$, $C_3 = 100 \mu\text{F}$, $C_4 = 50 \mu\text{F}$, $C_5 = 25 \mu\text{F}$. The given problem is conveniently solved by the method of node potentials, taking the node 4 as a primary one, that is $\varphi_4 = 0$. Since $\varphi_1 = U$, the problem will be reduced to the system of 2 equations.

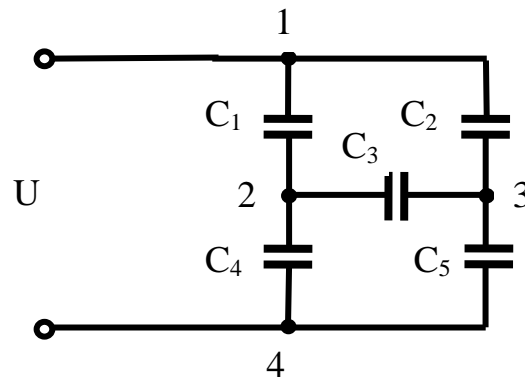

Figure 5. Circuit with five capacitors

Let us transcribe the system of equations

$$-\underline{\varphi}_1 \underline{Y}_{21} + \underline{\varphi}_2 \underline{Y}_{22} - \underline{\varphi}_3 \underline{Y}_{23} = 0, \quad (48)$$

$$-\underline{\varphi}_1 \underline{Y}_{31} - \underline{\varphi}_2 \underline{Y}_{32} + \underline{\varphi}_3 \underline{Y}_{33} = 0. \quad (49)$$

By substituting the expressions for first node potential as well as for the self- and mutual conductance, we will get

$$-U(j\alpha C_1) + \underline{\varphi}_2(j\alpha C_1 + j\alpha C_4 + j\alpha C_3) - \underline{\varphi}_3(j\alpha C_3) = 0, \quad (50)$$

$$-U(j\alpha C_2) - \underline{\varphi}_2(j\alpha C_3) + \underline{\varphi}_3(j\alpha C_2 + j\alpha C_3 + j\alpha C_5) = 0. \quad (51)$$

Let us determine the second node potential from the first equation and substitute it into the second one.

$$\underline{\varphi}_2 = \frac{U(j\alpha C_1) + \underline{\varphi}_3(j\alpha C_3)}{j\alpha C_1 + j\alpha C_4 + j\alpha C_3} = \frac{UC_1 + \underline{\varphi}_3 C_3}{C_1 + C_4 + C_3}, \quad (52)$$

$$\begin{aligned} & -U(j\alpha C_2) - \frac{UC_1 + \underline{\varphi}_3 C_3}{C_1 + C_4 + C_3} (j\alpha C_3) + \underline{\varphi}_3 (j\alpha C_2 + j\alpha C_3 + j\alpha C_5) = \\ & = -U(j\alpha C_2) - \frac{UC_1(j\alpha C_3)}{C_1 + C_4 + C_3} - \frac{\underline{\varphi}_3 C_3}{C_1 + C_4 + C_3} (j\alpha C_3) + \underline{\varphi}_3 (j\alpha C_2 + j\alpha C_3 + j\alpha C_5) = 0 \Leftrightarrow \\ & \Leftrightarrow -U(C_2) - \frac{UC_1(C_3)}{C_1 + C_4 + C_3} - \frac{\underline{\varphi}_3 C_3}{C_1 + C_4 + C_3} (C_3) + \underline{\varphi}_3 (C_2 + C_3 + C_5) = 0 \end{aligned} \quad (53)$$

Hence, the potentials are:

$$\underline{\varphi}_3 = \frac{UC_2 + \frac{UC_1 C_3}{C_1 + C_4 + C_3}}{C_2 + C_3 + C_5 - \frac{C_3^2}{C_1 + C_4 + C_3}} = 81.159 \text{ V}, \quad (54)$$

$$\underline{\varphi}_2 = \frac{UC_1}{C_1 + C_4 + C_3} + \frac{UC_2 + \frac{UC_1 C_3}{C_1 + C_4 + C_3}}{C_2 + C_3 + C_5 - \frac{C_3^2}{C_1 + C_4 + C_3}} \frac{C_3}{C_1 + C_4 + C_3} = 84.058 \text{ V}. \quad (55)$$

Henceforward it is easy to find voltages in capacities:

$$U_{C_1} = \underline{\varphi}_1 - \underline{\varphi}_2 = 18.841 \text{ V}, \quad U_{C_2} = \underline{\varphi}_1 - \underline{\varphi}_3 = 15.942 \text{ V}, \quad U_{C_3} = \underline{\varphi}_3 - \underline{\varphi}_2 = 2.899 \text{ V}, \quad (56)$$

$$U_{C_4} = \underline{\varphi}_2 = 81.159 \text{ V}, \quad U_{C_5} = \underline{\varphi}_3 = 84.058 \text{ V}. \quad (57)$$

Conclusions

1. The authors are the first to determine the class of nonstandard electrical engineering problems, aimed at analysing direct current electrical circuits, which include ideal reactive elements — ideal inductances and capacities. It is shown, that the solution of the highlighted class of problems through standard methods of theoretical electrical engineering is far too complex or almost impossible.

2. To solve the described problem it is proposed to extend the methods of nonstandard analysis with the problems of analysis of electrical circuits with ideal reactive elements. The advantages of this approach are proved by the examples of calculations of electrical circuits with inductances and capacities and as well of magnetic bound circuits.

3. With the aim of extending the sphere of usage of the methods of nonstandard analysis it is important to distinguish similar problems from diverse spheres of science and engineering, where differential calculation and extreme transitions are used and the solution of which with standard approaches is limited or impossible.

References

- 1 Donaldson J.A. The abstract Cauchy problem / J.A. Donaldson // *Journal of Differential Equations*. — 1977. — Vol. 25. — Iss. 3. — P. 400-409.
- 2 De Laubenfels R. Entire solutions of the abstract Cauchy problem / R. De Laubenfels // *Semigroup Forum*. — 1991. — Vol. 42. — P. 83-105.
- 3 Vedmitskiy Y.G. Newton binomial in the generalized Cauchy problem as exemplified by electrical systems / Y.G. Vedmitskiy, V.V. Kukharchuk, V.F. Hraniak, I.V. Vishtak, P. Kacejko, A. Abenov // *Proc. SPIE 10808, Photonics Applications in Astronomy, Communications, Industry, and High Energy Physics Experiments*. — 2018. — Vol. 108082M.
- 4 Zhen Wang. Uniqueness of generalized solution for the Cauchy problem of transportation equations / Wang Zhen, Ding Xiaqi // *Acta Mathematica Scientia*. — 1997. — Vol. 17. — Issue 3. — P. 341-352.
- 5 Sanchez-Ortiz. Cauchy Problem for a Stochastic Fractional Differential Equation with Caputo-Itô Derivative / Sanchez-Ortiz, Jorge, Omar U. Lopez-Cresencio, Francisco J. Ariza-Hernandez, P. Martin // *Mathematics*. — 2021. — V. 9. — P. 1-10.
- 6 Робинсон А. Введение в теорию моделей и математику алгебры / А. Робинсон. — М.: Наука, 1967. — 376 с.
- 7 Robinson A. *Non-Standard Analysis* / A. Robinson — Princeton: Princeton University Press. — 1996. — 308 p.
- 8 Jensen A. A computer oriented approach to “nonstandard analysis” / A. Jensen // *Studies in Logic and the Foundations of Mathematics*. — 1972. — Vol. 69. — P. 281-289.
- 9 Девис М. Прикладной нестандартный анализ / М. Девис; пер. с англ. — М.: Мир, 1980. — 240 с.
- 10 Гордон Е.И. Инфинитезимальный анализ / Е.И. Гордон, А.Г. Кусраев, С.С. Кутателадзе. — Новосибирск: Изд-во Ин-та математики, 2001. — 526 с.
- 11 Bell J. *A Primer of Infinitesimal Analysis* / J. Bell. — Cambridge University Press. — 1998. — 140 p.
- 12 Lutz R. *Nonstandard Analysis. A Practical Guide with Applications* / R. Lutz, M. Goze. — Berlin: Springer-Verlag. — 1981. — 261 p.
- 13 IEEE Standard Test Procedure for Polyphase Induction Motors and Generators. IEEE Std 112-2004 from 12th May 2004 (Revision of IEEE Std 112-1996). New York: American National Standard Institute.
- 14 Kucheruk V.Yu. Computer-measuring system of the induction motor’s dynamical torque-speed characteristics / V.Yu. Kucheruk, I.P. Kurytnik, Ye.Z. Oshanov, P.I. Kulakov, A.A. Semenov, D.Zh. Karabekova, A.K. Khassenov // *Bulletin of the University of Karaganda-Physics*. — 2019. — Vol. 2(94). — P. 92-100.
- 15 Hraniak V.F. Phase noncontact method and procedure for measurement of axial displacement of electric machine’s rotor / V.F. Hraniak, V.V. Kukharchuk, V.V. Bogachuk, Yu.G. Vedmitskiy // *Proc. SPIE 10808, Photonics Applications in Astronomy, Communications, Industry, and High-Energy Physics Experiments*. — 2018, Vol. 1080866.
- 16 Aree P. Analytical approach to determine speed-torque curve of induction motor from manufacturer data / P. Aree // *Procedia Computer Science*. — 2016. — Vol. 86. — p. 293-296.
- 17 Pflingsten G. Highly efficient approach to the simulation of variable-speed induction motor drives / G. Pflingsten, K. Hameyer // *Science Measurement & Technology IET*. — 2017. — Vol. 11. — P. 793-801.
- 18 Kojooyan-Jafari H. Parameter Estimation of Wound-Rotor Induction Motors from Transient Measurements / H. Kojooyan-Jafari, L. Monjo, F. Corcoles, J. Pedra // *IEEE Transactions on Energy Conversion*. — 2014. — Vol. 29. — P. 300-308.
- 19 Karpov Yu.O. Rozshyrennia oblasti zastosuvannya symvolnoho metodu otsinky elektrychnykh kil za dopomohoiu metodiv nestandartnoho analizu (chastyna 1) / Yu.O. Karpov, S.Sh. Katsyv, A.V. Kozlovskiy // *Visnyk Inzhenernoi akademii Ukrainy*. — 2013. — Vyp. 1. — S. 236-239.
- 20 Karpov Yu.O. Rozshyrennia oblasti zastosuvannya symvolnoho metodu otsiniuvannya elektrychnykh kil za dopomohoiu metodiv nestandartnoho analizu (chastyna 2) / Yu.O. Karpov, S.Sh. Katsyv, A.V. Kozlovskiy // *Visnyk Inzhenernoi akademii Ukrainy*. — 2013. — Vyp. 2. — S. 262-265.

С. Кацыв, В. Кухарчук, В. Кучерук, П. Кулаков, М. Грибов

Электртехникадағы стандартты емес талдау. Идеал реактивті элементтері бар тұрақты ток тізбектерін талдау

Мақалада теориялық электроника саласындағы стандартты емес талдау идеялары мен әдістерін қолдану ұсынылған. Идеалды индуктивтілік пен сыйымдылықты қамтитын тұрақты ток тізбектерін талдау теориялық электртехниканың стандартты әдістерімен тым күрделі немесе мүмкін емес екендігі көрсетілген. Бұл мәселені шешу үшін стандартты емес талдау әдістерін идеалды реактивті элементтері бар электр тізбектерін талдау мәселелерімен кеңейту ұсынылған. Авторлар идеалды реактивті элементтерді — идеалды индуктивтілік пен сыйымдылықты қамтитын тұрақты токтың электр тізбектерін талдауға бағытталған стандартты емес электротехникалық есептер класын анықтады. Арнайы есептер класын теориялық электртехниканың стандартты әдістерімен шешу өте қиын немесе мүмкін емес екендігі көрсетілген. Стандартты емес талдау әдістерін идеалды реактивті элементтері бар электр тізбектерін талдау міндеттерімен кеңейту ұсынылды. Бұл тәсілдің алынған артықшылықтары индуктивтілігі мен сыйымдылығы бар электр тізбектерін, сондай-ақ магниттік өткізгіштерді есептеу мысалдарымен расталады.

Кілт сөздер: шексіз аз сан, шексіздік, гипернақты сан, дәстүрлі емес сан, идеал реактивті элемент.

С. Кацыв, В. Кухарчук, В. Кучерук, П. Кулаков, М. Грибов

Нестандартный анализ в электротехнике. Анализ контуров постоянного тока с идеальными реактивными элементами

В статье предложено использование идей и методов нестандартного анализа в области теоретической электроники. Показано, что анализ цепей постоянного тока, включающих идеальные индуктивности и емкости, стандартными методами теоретической электротехники слишком сложен или почти невозможен. Для решения этой проблемы предложено расширить методы нестандартного анализа задачами анализа электрических цепей с идеальными реактивными элементами. Авторы определили класс нестандартных электротехнических задач, направленных на анализ электрических цепей постоянного тока, включающих в себя идеальные реактивные элементы — идеальные индуктивности и емкости. Показано, что решение выделенного класса задач стандартными методами теоретической электротехники слишком сложно или почти невозможно. Предложено расширить методы нестандартного анализа задачами анализа электрических цепей с идеальными реактивными элементами. Полученные преимущества такого подхода подтверждаются примерами расчетов электрических цепей с индуктивностями и емкостями, а также магнитопроводов.

Ключевые слова: бесконечно малое число, бесконечность, гипердействительное число, нетрадиционное число, идеальный реактивный элемент.

References

- 1 Donaldson, J.A. (1977). The abstract Cauchy problem. *Journal of Differential Equations*, 25(3), 400-409.
- 2 De Laubenfels, R. (1991) Entire solutions of the abstract Cauchy problem. *Semigroup Forum*, 42, 83–105.
- 3 Vedmitskiy, Y.G., Kukharchuk, V.V., Hraniak, V.F., Vishtak, I.V., Kacejko, P., & Abenov, A. (2018). Newton binomial in the generalized Cauchy problem as exemplified by electrical systems. *Proc. SPIE 10808, Photonics Applications in Astronomy, Communications, Industry, and High Energy Physics Experiments*, 108082M.
- 4 Zhen Wang, & Xiaqi Ding (1997). Uniqueness of generalized solution for the Cauchy problem of transportation equations. *Acta Mathematica Scientia*. 17(3), 341-352.
- 5 Sanchez-Ortiz, Jorge, Omar, U. Lopez-Cresencio, Francisco, J. Ariza-Hernandez, & Martin, P. (2021). Cauchy Problem for a Stochastic Fractional Differential Equation with Caputo-Itô Derivative. *Mathematics*, 9, 1-10.
- 6 Robinson, A. (1967). *Vvedenie v teoriyu modelei i matematiki algebrы [Introduction into the theory of models and mathematics of algebra]*. Moscow: Nauka [in Russian].
- 7 Robinson, A. (1996). *Non-Standard Analysis*. Princeton: Princeton University Press.
- 8 Jensen, A. (1972). A computer oriented approach to “nonstandard analysis, *Studies in Logic and the Foundations of Mathematics*, 69, 281-289.
- 9 Devis, M. (1980). *Prikladnoi nestandartnyi analiz [Applied non-standard analysis]*. Moscow: Mir [in Russian].

- 10 Gordon, E.Y., Kusraev, A.G., & Kutateladze, S.S. (2001). *Infinitezimalnyi analiz* [Infinitesimal Analysis]. Novosibirsk: Izdatelstvo Instituta matematiki [in Russian].
- 11 Bell, J. (1998). *A Primer of Infinitesimal Analysis*. Cambridge University Press.
- 12 Lutz, R., & Goze, M. (1981). *Nonstandard Analysis. A Practical Guide with Applications*. Berlin: Springer-Verlag.
- 13 IEEE Standard Test Procedure for Polyphase Induction Motors and Generators (2004). IEEE Std 112–2004 from 12th May 2004 (Revision of IEEE Std 112–1996). New York: American National Standard Institute.
- 14 Kucheruk, V.Yu., Kurytnik, I.P., Oshanov, Ye.Z., Kulakov, P.I., Semenov, A.A., Karabekova, D.Zh., & Khasenov, A.K. (2019). Computer-measuring system of the induction motor's dynamical torque-speed characteristics. *Bulletin of the University of Karaganda-Physics*, 2(94), 92–100.
- 15 Hraniak, V.F., Kukharchuk, V.V., Bogachuk, V.V., & Vedmitskyi, Yu.G. (2018). Phase noncontact method and procedure for measurement of axial displacement of electric machine's rotor. *Proc. SPIE 10808, Photonics Applications in Astronomy, Communications, Industry, and High-Energy Physics Experiments*, 1080866.
- 16 Aree, P. (2016). Analytical approach to determine speed-torque curve of induction motor from manufacturer data. *Procedia Computer Science*, 86, 293–296.
- 17 Pflingsten, G., & Hameyer, K. (2017). Highly efficient approach to the simulation of variable-speed induction motor drives. *Science Measurement & Technology IET*, 11, 793–801.
- 18 Kojooyan-Jafari, H., Monjo, L., Corcoles, F., & Pedra, J. (2014). Parameter Estimation of Wound-Rotor Induction Motors from Transient Measurements. *IEEE Transactions on Energy Conversion*, 29, 300–308.
- 19 Karpov, Yu.O., Katsyv, S.Sh., & Kozlovskiy, A.V. (2013). Rozshyrennia oblasti zastosuvannia symvolnoho metodu otsinky elektrychnykh kil za dopomohoiu metodiv nestandardnoho analizu (chastyna 1) [Expanding the domain of applying a symbolic method of estimation of electric circuits through the methods of non-standard analysis (Part 1)]. *Visnyk Inzhenernoi akademii Ukrainy — Bulletin of the Engineering Academy of Ukraine*, 1, 236-239 [in Ukrainian].
- 20 Karpov, Yu.O., Katsyv, S.Sh., & Kozlovskiy, A.V. (2013). Rozshyrennia oblasti zastosuvannia symvolnoho metodu otsiniuvannia elektrychnykh kil za dopomohoiu metodiv nestandardnoho analizu (chastyna 2) [Expanding the domain of applying a symbolic method of estimation of electric circuits through the methods of non-standard analysis (Part 2)]. *Visnyk Inzhenernoi akademii Ukrainy — Bulletin of the Engineering Academy of Ukraine*, 2, 262-265 [in Ukrainian].