

---

# КОНДЕНСАЦИЯ ЛАНҒАН КҮЙДІҢ ФИЗИКАСЫ ФИЗИКА КОНДЕНСИРОВАННОГО СОСТОЯНИЯ PHYSICS OF THE CONDENSED MATTER

UDC 530.12

V.V. Arkhipov, T.M. Orymbay, P.A. Kisabekova

*Ye.A. Buketov Karaganda State University, Kazakhstan  
(E-mail: midav\_73@mail.ru)*

## Geodesics in the closed accelerating University

The need to introduce in the current cosmological models, dark energy and dark matter raises the question of revision of the basic concepts of the structure of the Universe. In particular, the accelerated expansion of the Universe can significantly affect the observed motion of free bodies. Conclusions about the dynamics of remote astrophysical systems may not be correct if they are based on an incorrect interpretation of the observed nature of the motion. In view of this, it seems relevant to study the general laws of motion in an accelerating expanding space. The present work is devoted to the study of the nature of the motion of test particles in a maximally symmetrical, closed, accelerating Universe. As a concrete model, we study the anti-de Sitter space, that is, a space with positive scalar curvature. More specifically, as a model, a four-dimensional one-sheeted hyperboloid is embedded in a flat five-dimensional enveloping space characterized by the Minkowski metric. The orientation of the hyperboloid is along the time axis. This choice of geometry allows you to maintain the straightness of 0-geodesics, both in the enclosed and in the enclosing spaces. The Minkowski metric of the ambient space induces a metric on the hypersurface of a hyperboloid that simulates an accelerated expanding spatially closed Universe. The pseudo-Cartesian coordinate system is introduced for saving formal equality of space dimensions of the space-time. The basic geometrical characteristics such as the metrics and the connection are calculated in the coordinate system. The system of geodesic equations was solved for partial case of hyperbolic space-time. The choice supplies the possibility to investigate the common properties of spatial accelerating University. It is shown that number of faster-than-light particles (tachyons) has to be decreasing in the model due to annihilation processing.

*Keywords:* anti-de Sitter space, geodesics, accelerating University, pseudo-Cartesian coordinates, curvature, dynamics of probe particles.

### Introduction

The recent discoveries in the observing astronomy lead us to the revolutionary conclusions about necessary of deep revision for our theoretical knowledge on the physics of the University.

The first supposition to this was some discrepancy between observables of the mass distributions in spiral Galaxies and theoretical predictions of neither Newtonian mechanics nor General Relativity. The solution of the problem demanded introducing dark matter [1] that is not radiating but takes part in gravitational interaction. Estimation its quantity leads to the conclusion about the curvature of the universe as very closed to flat one. Analysis of luminous excitement of supernovas developed into discovery of the accelerating expansion of the universe. This cannot be agreement with action only attracting forces between objects [2]. There are several very different approaches to explanation this phenomenon [3].

Among the main ones are returning of  $\Lambda$ -item into Einstein equations and various combinations of geometrical approaches with introduction of exotic matters such as mirror matter [4] *et cetera*.

The alternative theories like Modified Newtonian Dynamics [5] have some popularity as well.

At present time the question of geometrical properties of the universe is remained open. Observable plainness of the universe stimulates appearance of the models with possibilities to reconcile this property with insularity of its spatial part (see [6]). We want to note that we don't see any serious physical substantia-

tion of the idea of the spatial closed university apart from some paradoxes that all have acceptable explanations.

In the present work a model of the most symmetric three-dimensional closed universe is considered. The model allows investigate common properties of free motion in the case of accelerating expansion of the universe.

### 1. Pseudo-Cartesian coordinates

Pseudo-Euclidian metrics of the bulk space-time

$$dS^2 = dT^2 - dX^2 - dY^2 - dZ^2 - dW^2.$$

Here and further we take the light velocity  $c=1$ . Equation of a hyper-sphere in the spatial part of the space-time

$$R^2 = X^2 + Y^2 + Z^2 + W^2.$$

Pseudo-Cartesian coordinates on the hyper-sphere:

$$x = R\alpha, \quad y = R\beta, \quad z = R\gamma, \quad (1)$$

where  $\alpha, \beta, \gamma$  are the angular coordinates (Fig. 1).

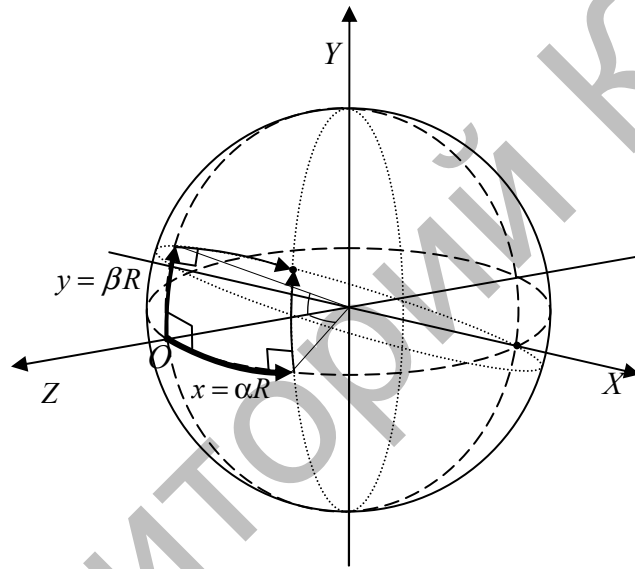

Figure 1. This is an illustration of the correlation between the angular and pseudo-Cartesian coordinates on the example of a two-dimensional sphere in the three-dimensional bulk space

It can be shown [7] that

$$X = \frac{R \cdot \operatorname{tg} \alpha}{\sqrt{1 + \operatorname{tg}^2 \alpha + \operatorname{tg}^2 \beta + \operatorname{tg}^2 \gamma}}, \quad Y = \frac{R \cdot \operatorname{tg} \beta}{\sqrt{1 + \operatorname{tg}^2 \alpha + \operatorname{tg}^2 \beta + \operatorname{tg}^2 \gamma}},$$

$$Z = \frac{R \cdot \operatorname{tg} \gamma}{\sqrt{1 + \operatorname{tg}^2 \alpha + \operatorname{tg}^2 \beta + \operatorname{tg}^2 \gamma}}, \quad W = \frac{R}{\sqrt{1 + \operatorname{tg}^2 \alpha + \operatorname{tg}^2 \beta + \operatorname{tg}^2 \gamma}}.$$

In the dynamical symmetric Universe we have  $R = R(T)$ . So, interval on the closed space-time takes the form

$$ds^2 = \left( 1 - \left( \frac{\partial R(T)}{\partial T} \right)^2 \right) dT^2 - R^2(T) d\sigma^2,$$

where  $d\sigma$  is the distance on the hyper-sphere of unit radius in the angular coordinates. Now we can introduce the time on the hyper-surface as

$$\sqrt{1 - \left( \frac{\partial R(T)}{\partial T} \right)^2} dT = dt. \quad (2)$$

After substitution into previous expression we have the metric in the next simple view:

$$ds^2 = dt^2 - R^2(t)d\sigma^2.$$

We will use designation  $g_{\mu\nu}$  for the metric of the closed space-time in pseudo-Cartesian coordinates  $(t, x, y, z)$  and  $\tilde{g}_{\mu\nu}$  if angular coordinates  $(t, \alpha, \beta, \gamma)$  are used. Here and further the Greek type indexes take on the values 0, 1, 2, 3. The Latin indexes numerate only spatial coordinates and take on the values 1, 2, 3. If we introduce the cosmological parameter as

$$a(t) = \frac{R(t)}{R_0},$$

then we have the standard expression for the Freedman-Robertson-Walker metric

$$ds^2 = dt^2 - a^2(t)R_0^2 d\sigma^2.$$

The metric in the angular coordinates is calculated in [7] and one has the next view  $(\alpha_i = (\alpha, \beta, \gamma))$ ,  $\Delta = 1 + \text{tg}^2 \alpha + \text{tg}^2 \beta + \text{tg}^2 \gamma$ :

$$\begin{aligned} \tilde{g}_{00} &= 1, \quad \tilde{g}_{0i} = 0, \quad \tilde{g}^{00} = 1, \quad \tilde{g}^{0i} = 0, \\ \tilde{g}_{ii} &= -\frac{(\Delta - \text{tg}^2 \alpha_i)(1 + \text{tg}^2 \alpha_i)^2}{\Delta^2} R^2(t), \quad \tilde{g}_{ij} \Big|_{i \neq j} = \frac{(1 + \text{tg}^2 \alpha_i)(1 + \text{tg}^2 \alpha_j) \text{tg} \alpha_i \text{tg} \alpha_j}{\Delta^2} R^2(t), \\ \tilde{g}^{ii} &= -\frac{\Delta}{1 + \text{tg}^2 \alpha_i} \frac{1}{R^2(t)}, \quad \tilde{g}^{ij} \Big|_{i \neq j} = -\frac{\Delta \cdot \text{tg} \alpha_i \text{tg} \alpha_j}{(1 + \text{tg}^2 \alpha_i)(1 + \text{tg}^2 \alpha_j)} \frac{1}{R^2(t)}. \end{aligned}$$

The connection can be calculated due to its definition

$$\Gamma_{\alpha\beta}^{\mu} = \frac{1}{2} g^{\mu\nu} (\partial_{\alpha} g_{\nu\beta} + \partial_{\beta} g_{\alpha\nu} - \partial_{\nu} g_{\alpha\beta}).$$

The only non-trivial components:

$$\begin{aligned} \Gamma_{ij}^0 \Big|_{i \neq j} &= -\frac{(1 + \text{tg}^2 \alpha_i)(1 + \text{tg}^2 \alpha_j) \text{tg} \alpha_i \text{tg} \alpha_j}{\Delta^2} R(t) \partial_0 R(t), \\ \Gamma_{ii}^0 &= \frac{(\Delta - \text{tg}^2 \alpha_i)(1 + \text{tg}^2 \alpha_i)^2}{\Delta^2} R(t) \partial_0 R(t), \\ \Gamma_{ii}^i &= 2 \frac{\text{tg} \alpha_i (\Delta - 1 - \text{tg}^2 \alpha_i)}{\Delta}, \\ \Gamma_{ki}^k \Big|_{k \neq i} &= -\frac{\text{tg} \alpha_i (1 + \text{tg} \alpha_i)}{\Delta}, \\ \Gamma_{j0}^i &= \frac{\partial_0 R(t)}{R(t)} \delta_j^i. \end{aligned}$$

Let's consider a partial case when the motion has place only along  $x$ -axis. In other words we will put  $\beta = \gamma = 0$ . The definition of geodesic equations

$$\frac{d^2 x^{\mu}}{ds^2} + \Gamma_{\alpha\beta}^{\mu} \frac{dx^{\alpha}}{ds} \frac{dx^{\beta}}{ds} = 0$$

gives the next system:

$$\begin{aligned} \frac{d^2 t}{ds^2} + \Gamma_{11}^0 \left( \frac{d\alpha}{ds} \right)^2 &= 0, \\ \frac{d^2 \alpha}{ds^2} + 2\Gamma_{01}^1 \frac{dt}{ds} \frac{d\alpha}{ds} + \Gamma_{11}^1 \left( \frac{d\alpha}{ds} \right)^2 &= 0. \end{aligned}$$

After the choice  $\beta = 0$  and  $\gamma = 0$  the necessary connection components are

$$\Gamma_{11}^1 = 0, \quad \Gamma_{11}^0 = R(t) \partial_0 R(t), \quad \Gamma_{10}^1 = \frac{\partial_0 R(t)}{R(t)}.$$

Therefore the system of geodesic equations takes the form:

$$\frac{d^2 t}{ds^2} + R(t) \partial_0 R(t) \left( \frac{d\alpha}{ds} \right)^2 = 0, \quad (3)$$

$$\frac{d^2 \alpha}{ds^2} + 2 \frac{\partial_0 R(t)}{R(t)} \frac{dt}{ds} \frac{d\alpha}{ds} = 0. \quad (4)$$

Now, one needs to choose the concrete view of the function  $R(t)$  to resolve this system.

## 2. Universe as a Hyperspace

Let's take a form of the Universe as one-sheet hyperboloid oriented along the time axis (the sheet is supposed to be three-dimensional one). So the dependence of the radius from the world time will have the next simple view

$$R(T) = \sqrt{R_0^2 + T^2}.$$

This choice is in agreement with the conception of accelerated swelling of the Universe at the current stage of the evolution (Fig. 2).

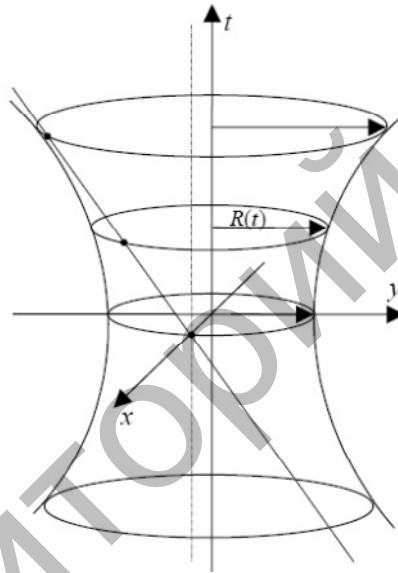

Figure 2. A two-dimensional model of the one-sheet hyperboloid subspace embedded into a bulk space-time

Taking account that

$$\frac{dR(T)}{dT} = \frac{T}{\sqrt{R_0^2 + T^2}}$$

and using it together with (2), after integration we will have the next relation between the world time and time on the hypersurface

$$t = R_0 \operatorname{arcsch} \frac{T}{R_0} + \operatorname{const}.$$

Therefore, the  $R(t)$  dependence has the next simple view

$$R(t) = R_0 \operatorname{ch} \frac{t}{R_0}.$$

Further it will be convenient to introduce a new dimensionless variable for the time

$$\tau = t / R_0.$$

So, the system (3), (4) takes the next form

$$\frac{d^2\tau}{ds^2} + \frac{1}{2} \operatorname{sh} 2\tau \left( \frac{d\alpha}{ds} \right)^2 = 0, \tag{5}$$

$$\frac{d^2\alpha}{ds^2} + 2 \operatorname{th} \tau \frac{d\tau}{ds} \frac{d\alpha}{ds} = 0.$$

It is easy to see that the last equation can be rewritten in the view

$$\frac{d}{ds} \left( \operatorname{ch}^2 \tau \frac{d\alpha}{ds} \right) = 0.$$

It implies that

$$\frac{d\alpha}{ds} = \frac{a}{\operatorname{ch}^2 \tau}, \tag{6}$$

where  $a = \text{const}$ . After the substitution it into (5) we get to the equation with one variable

$$\frac{d^2\tau}{ds^2} = -\frac{\operatorname{sh} \tau}{\operatorname{ch}^3 \tau} a^2,$$

that coincides with the equation of the two-dimensional case considered in the article [8]. It can be checked that its solution can be written as

$$\operatorname{sh} \tau = \sqrt{1 + \frac{a^2}{\kappa^2}} \operatorname{sh}(\kappa(C \pm s)),$$

where  $\kappa$  and  $C$  are new constants. It is obvious the constant  $C$  charges for the origin point of the parameter  $s$ . So, let's make a simplest choice  $\tau(0) = 0$  and take the sign as «+» to run along the geodesics in the direction of  $\tau$  increasing. So we put

$$\operatorname{sh} \tau = \sqrt{1 + \frac{a^2}{\kappa^2}} \operatorname{sh}(\kappa s). \tag{7}$$

From (6) we have

$$\frac{d\alpha}{ds} = \frac{a}{\operatorname{ch}^2(\kappa s) + (a/\kappa)^2 \operatorname{sh}^2(\kappa s)}.$$

Resolution of the equation gives us

$$\operatorname{tg}(\alpha - \alpha_0) = \frac{a}{\kappa} \operatorname{th}(\kappa s),$$

where  $\alpha_0$  is a new constant with obvious physical meaning. Using (7) we get to the equation of trajectory in the  $\alpha, \tau$  — coordinates (as it have been chosen above the motion takes place only in the one plane!):

$$\alpha = \operatorname{arctg} \frac{\operatorname{sh} \tau}{\sqrt{1 + (\kappa/a)^2 \operatorname{ch}^2 \tau}} + \alpha_0.$$

Therefore for the pseudo-Cartesian coordinate  $x = \alpha R(\tau)$  (1) we have:

$$x = R_0 \operatorname{ch} \tau \cdot \operatorname{arctg} \frac{\operatorname{sh} \tau}{\sqrt{1 + (\kappa/a)^2 \operatorname{ch}^2 \tau}} + \alpha_0 R_0 \operatorname{ch} \tau.$$

Let's express the unknown constants through initial conditions of the next view:

$$x(0) = x_0, \quad \left. \frac{dx}{d\tau} \right|_{\tau=0} = v_0.$$

After some math transformation we have

$$x = R_0 \operatorname{ch} \tau \cdot \operatorname{arctg} \frac{\operatorname{sh} \tau}{\sqrt{\left( \frac{R_0}{v_0} \right)^2 \operatorname{ch}^2 \tau - \operatorname{sh}^2 \tau}} + x_0 \operatorname{ch} \tau.$$

It is easy to see that the Euclidian limit  $R_0 \rightarrow \infty$  for this expression has the simplest view of a uniform motion:

$$x = v_0 \tau + x_0.$$

The analysis of the result coincides with one for one-dimensional case that was done in [8]. The most important result was concluded in the statement about disappearing of tachyons in the late universe in the frames of the model. But now the same result can be generalized to the common case of spatially three-dimensional space.

## References

- 1 Рябов В.А. Поиски частиц темной материи / В.А. Рябов, В.А. Царев, А.М. Цховребов // УФН. — 2008. — Т. 178, № 11. — С.1129–1161.
- 2 Перлмуттер С. Измерение ускорения космического расширения по сверхновым / С. Перлмуттер // УФН. — 2013. — Т. 183, № 10. — С. 1060–1077.
- 3 Baryshev Yu.V. Field Theory of Gravitation: Desire and Reality / Yu.V. Baryshev. [Электронный ресурс]. Режим доступа: arXiv: gr-qc/9912003v1 1 Dec 1999.
- 4 Блинные С.И. Зеркальное вещество и другие модели для темной материи / С.И. Блинные // УФН. — 2014. — Т. 184, № 2. — С. 194–199.
- 5 Milgrom M. A modification of the Newtonian dynamics as a possible alternative to the hidden mass hypothesis / M. Milgrom // Astrophys. J. — 1983. — Vol. 270. — P. 365–370.
- 6 Luminet J.P. Dodecahedral space topology as an explanation for weak wide-angle temperature correlations in the cosmic microwave background / J.P. Luminet. [Электронный ресурс]. Режим доступа: arXiv: astro-ph/0310253v1 9 Oct 2003.
- 7 Архипов В.В. Импульс частицы в пространстве анти-де Ситтера / В.В. Архипов, С.Н. Кытманов // Вестн. Караганд. ун-та. Сер. Физика. — 2014. — № 3(75). — С. 80–85.
- 8 Arkhipov V.V. Geodesics in a Two-Dimensional Model of Closed Spacetime / V.V. Arkhipov // Russian Physics Journal. — 2014. — Vol. 57, No. 8. — P. 1023–1029.

В.В. Архипов, Т.М. Орымбай, П.Э. Қисабекова

## Тұйық үдеуі өзгеріп отыратын Ғаламның геодезия сызықтары

Заманауи ғарыштық модельдерге қара энергия және қара материяны енгізу қажеттілігі Ғаламның құрылымы туралы барлық негізгі түсініктерді қайта қарау туралы сұрақты ұсынады. Сондай-ақ Ғаламның қарқынды ұлғаюы еркін денелердің бақыланып отырған қозғалысында айтарлықтай көрінеді. Қашықтағы астрофизикалық жүйелердің динамикасы туралы қорытындылар қозғалыстың бақыланып отырған сипатының қате талдауына негізделсе, онда олар дұрыс болмауы мүмкін. Осыған байланысты қарқынды ұлғайып жатқан кеңістіктегі қозғалыстардың жалпы заңдарын зерттеу өзекті болып табылады. Мақала барынша симметриялы, тұйық, тез өзгеріп отыратын Ғаламдағы сынақ бөлшектердің қозғалыс сипатын зерттеуге арналған. Нақты модель ретінде анти-де Ситтердің кеңістігі, яғни оң скалярлық қисықтық кеңістігі, зерттелді. Нақтылау үлгі ретінде Минковский метрикасымен сипатталатын, жазық бес өлшемді аумақты кеңістікке енгізілген төрт өлшемді бір қуысты гиперболоид таңдалды. Гиперболоидтің бағыты — уақыт осінің бойы. Геометрияның бұл таңдауы ауқымды кеңістікте 0-геодезиялықтың түзу сызықтылығын сақтауға мүмкіндік береді. Ауқымды кеңістіктің Минковский метрикасы қарқынды ұлғайып жатқан тұйықталған кеңістік Ғаламды кескіндеуші гиперболоидтің гипержазықтығына метриkanı ықпалдандырады. Кеңістік-уақыттың кеңістік өлшемдерінің формалды теңдік сақтау үшін псевдодекарттық координаттар жүйесі енгізілді. Осы координаттар жүйесі үшін негізгі геометриялық сипаттамалар — метрика және байланыстыру коэффициенттері есептелген. Геодезия сызықтары үшін теңдеулер жүйесі гиперболалық кеңістік-уақыттың жеке жағдайында шешілген. Бұл таңдау кеңістікте үдеуі өзгеріп отыратын Ғаламның жалпы қасиеттерін зерттеуге мүмкіндік береді. Сонымен қатар осы үлгіде аннигиляция процестері үшін жарық жылдамдығынан артық жылдамдықпен қозғалатын бөлшектер саны — тахион сандары уақыт бойынша төмендеу тиіс екені көрсетілген.

*Кілт сөздер:* анти-де-Ситтер кеңістігі, үдемелі Ғалам, псевдодекарттық координата, қисықтық, сынақ бөлшектердің динамикасы.

В.В. Архипов, Т.М. Орымбай, П.А. Кисабекова

## Геодезические в замкнутой ускоряющейся Вселенной

Необходимость введения в современных космологических моделях темной энергии и темной материи ставит вопрос о ревизии всех основных представлений о строении Вселенной. В частности, ускоренное расширение Вселенной может значительным образом сказаться на наблюдаемом движении сво-

бодных тел. Выводы о динамике удаленных астрофизических систем могут оказаться некорректными, если они будут базироваться на неверной интерпретации наблюдаемого характера движения. Ввиду этого представляется актуальным исследование общих законов движения в ускоренно расширяющемся пространстве. Статья посвящена исследованию характера движения пробных частиц в максимально симметричной, замкнутой, ускоряющейся Вселенной. В качестве конкретной модели исследуется пространство анти-де Ситтера, т.е. пространство с положительной скалярной кривизной. Более конкретно в качестве модели выбран четырехмерный однополостной гиперболоид, вложенный в плоское пятимерное объемлющее пространство, характеризующееся метрикой Минковского. Ориентация гиперболоида — вдоль оси времени. Такой выбор геометрии позволяет сохранить прямолинейность 0-геодезических как во вложенном, так и в объемлющем пространствах. Метрика Минковского объемлющего пространства индуцирует метрику на гиперповерхности гиперболоида, моделирующего ускоренно расширяющуюся пространственно-замкнутую Вселенную. Для сохранения формального равноправия пространственных измерений пространства-времени введена псевдодекартова система координат. Для этой системы координат вычислены основные геометрические характеристики — метрика и коэффициенты связности. Система уравнений для геодезических решена для частного случая гиперболического пространства-времени. Этот выбор позволяет исследовать общие свойства пространственно ускоряющейся Вселенной. Показано, что в данной модели число сверхсветовых частиц — тахионов — должно понижаться с течением времени из-за аннигиляционных процессов.

*Ключевые слова:* пространство анти-де Ситтера, ускоряющаяся Вселенная, псевдодекартова координата, кривизна, динамика пробных частиц.

## References

- 1 Ryabov, V.A., Tsarev, V.A., & Tskhovrebov, A.M. (2008). Poiski chastits temnoi materii [The search for dark matter particles] *Uspekhi Fizicheskikh Nauk — Successes in physical sciences*, 178(11), 1129–1161 [in Russian].
- 2 Perlmutter, S. (2013). Izmerenie uskoreniia kosmicheskogo rasshireniia po sverkhnovym [Measuring the acceleration of the cosmic expansion using supernovae] *Uspekhi Fizicheskikh Nauk — Successes in physical sciences*, 183(10), 1060–1077 [in Russian].
- 3 Baryshev, Yu.V. (1999, 1 Dec.). Field Theory of Gravitation: Desire and Reality *arxiv.org* Retrieved from: arXiv: gr-qc/9912003v1.
- 4 Blinnikov, S.I. (2014). Zerkalnoe veshchestvo i druhie modeli dlia temnoi materii [Mirror matter and other dark matter models] *Uspekhi Fizicheskikh Nauk — Successes in physical sciences*, 184(2), 194–199 [in Russian].
- 5 Milgrom, M. (1983). A Modification of the Newtonian dynamics as a possible alternative to the hidden mass hypothesis *Astrophys. J.*, 270, 365–370.
- 6 Luminet, J.P. (2003, 9 Oct). Dodecahedral space topology as an explanation for weak wide-angle temperature correlations in the cosmic microwave background *arxiv.org* Retrieved from: arXiv: astro-ph/0310253v1.
- 7 Arkhipov, V.V., & Kytmanov, S.N. (2014). Impuls chastitsy v prostranstve anti-de Sittera [The Momentum of a Particle in the Anti-de Sitter Space] *Vestnik Karahandinskoho universiteta. Seriya Fizika — Bulletin of the Karaganda University. Physics Series*, 3(75), 80–85 [in Russian].
- 8 Arkhipov, V.V. (2014). Geodesics in a Two-Dimensional Model of Closed Spacetime *Russian Physics Journal*, 57(8), 1023–1029.