

EDDY CURRENT METHOD FOR STUDYING INHOMOGENEITIES AND DEFECTS IN THIN METAL FILMS

Malikov V.N.^{1*}, Katasonov A.O.¹, Ishkov A.V.², Fadeev D.A.¹, Voinash S.A.³,
Vornacheva I.V.⁴, Zagidullin R.R.³, Shmykova P.A.¹

¹Altai State University, Barnaul, Altai Territory, Russia, osys11@gmail.com

²Altai State Agricultural University, Barnaul, Russia

³Kazan Federal University, 18 Kremlin Street, Kazan, Russia

⁴South-West State University, Kursk, Russia

The variety of structure and specific properties associated with the small thickness of thin metal films lead to the fact that their physical characteristics differ significantly from the characteristics of the same materials in the bulk state. To determine the characteristics of thin metal films, the development of new non-destructive research methods is relevant. The article substantiates the advantages of the eddy current testing method for studying the surface of thin metal films of various metals. The design of a subminiature eddy current transducer designed to study the electrical conductivity, thickness and degree of damage of thin metal films is presented, and a hardware and software complex is designed that allows the control of the developed transducer. The study of metal films made it possible to show the inhomogeneity of the distribution of the substance over the surface of the substrate. The dependence of the signal amplitude of the developed transducer on the film thickness was also determined. To verify the results obtained, studies of the light transmittance of the films were carried out using the photometric method. Comparison of the measurement results obtained by the two methods showed a high degree of agreement between the two developed methods for studying films.

Keywords: thin films, metals, eddy current transducer, materials research, film inhomogeneity.

1. Introduction

The rapidly developing electronics market requires the active development of technologies related to means of studying the characteristics of manufactured products, including studies of the condition of thin metal films. Analyzing the features of the development of new tools for studying thin-film structures, the following can be noted:

- the tasks of industrial research of materials and thin-film structures are becoming particularly relevant in the modern scientific and technical sphere;
- methods and means of non-destructive research of materials are among the most promising in the modern instrument-making industry;

Among the methods for studying metal objects, the eddy current method occupies a special place. It allows the study of objects such as massive conductive structures, layered composite materials, metal sheets, as well as objects with a small thickness, the most typical example of which is thin metal films.

The scientific and technical field associated with the production and use of thin metal films has grown rapidly over the past decades and occupies key positions in many branches of modern production. Currently, in the conditions of the scientific and technological revolution, the use of thin films in microelectronics, microwave technology, optics and many other branches of science and technology opens up prospects for the creation and improvement of not only new devices, but also entire technological areas.

The variety of structure and specific properties associated with the small thickness of such objects leads to the fact that their physical characteristics can differ significantly from the characteristics of the same materials in a massive state. In this regard, thin films are of interest to physics as objects on which new phenomena and patterns can be discovered or known ones can be explained. For technology, the study of thin films opens up the possibility of developing and creating fundamentally new devices and technologies.

In addition, thin films allow the development of new experimental methods of electroanalysis and sensing [1]. It should also be noted that work is currently being actively carried out on the synthesis and

production of new materials with specified characteristics, and research is also being conducted on the possibility of changing these characteristics under the influence of external factors (electric, magnetic, as well as acoustic fields, temperature, lighting, pressure and etc.) [2–5]. In this case, as a rule, such materials are often used as thin-film elements. For the full use of thin films in various fields of electronics, complete information about their material constants and physical parameters, both integral and local, is required. Therefore, new methods are needed to characterize the materials under study in the form of thin films.

To determine the characteristics of thin metal films, the following non-destructive research methods are widely used: atomic force microscopy, scanning electron microscopy, X-ray diffractometry, spectroscopic ellipsometry, four-probe method, eddy current method [6-8].

The eddy current method has significant advantages over other methods. It provides the ability to simply and accurately make measurements without the need for direct contact with the object under study, and also provides the ability to make measurements directly in the environment in which the film is growing, and this makes it possible to more accurately control the film growth process.

The disadvantage of this method is the low frequency of the electromagnetic field used in research. The characteristic frequency range used in instruments that implement this research method is 500 Hz – 1 MHz, which is insufficient when studying objects with a thickness of less than 1 micron. The use of a higher frequency is complicated by the need to digitize the signal of the eddy current transducer, which carries information about the object of study. In addition, one of the aspects of the development of the modern eddy current method of materials research is the automation of the scanning process. Automation of the scanning process can significantly increase the speed and accuracy of research.

The research team at Tsinghua University (Beijing) is also developing eddy current transducers for measuring the thickness of thin copper films in the process of chemical-mechanical planarization (CMP - one of the stages in the production of microelectronics). In their scientific works, they report on the creation of planar eddy current transducers without a core, both a surface-mount type, with a transducer diameter of 6 mm and an operating frequency of 0.75 MHz, and a pass-through type with a coil radius of 2.5 mm and an operating frequency of 0.5 MHz. The developed transducers showed high accuracy in determining the thickness of copper film in the range of 100 – 500 nm, but the dimensions of the transducers provide low spatial resolution [9, 10].

Works [11-15] describe examples of the use of single-part and multi-frequency eddy current testing methods for studying thin conductive films. In the case of measuring the thickness or electrical conductivity of films with pronounced magnetic properties, it is advisable to use the pulsed eddy current method [16, 17].

In the absence of magnetization of a thin film, the eddy current testing method is often used, based on the changing frequency of the electromagnetic field of the eddy current sensor. This method makes it possible to study films at different depths by changing the signal frequency. It is used in the study of multilayer plates, above which the measuring coil of an eddy current transducer is placed. At the same time, the change in the impedance of the coil during its interaction with each of the conducting layers was assessed, based on which the thickness and conductivity of each layer can be found [18-22].

However, this method is difficult to use for films with a thickness of less than 10 μm [20, 23].

The authors in [24, 25] studied the change in the impedance of a coil located above a conducting plate with a single-layer metal coating, which, in fact, is a model of a thin metal film. The feasibility of using a transformer overhead eddy-current technique (ETC) for studying thin metal films has been established, and information has also been obtained that such studies require information either on the thickness of the film or on its electrical conductivity [20, 23-27].

However, these works contain very little information about determining the degree of defectiveness of thin metal films.

Thus, an urgent task in the development of the eddy current method for studying materials is the creation of a hardware and software complex that allows one to study the homogeneity and defectiveness of a thin metal film. A promising direction of development seems to be the automatic movement of the sensor over the surface of the film under study with a small step and registration of the eddy-current probe (ECP) signal at each measurement point in real time.

2. Materials and methods of research

Based on the conclusions drawn from the analysis of the first chapter and previous studies [28-31], a subminiature eddy current transducer was developed, designed to study the electrical conductivity, thickness and degree of damage of thin metal films, and a hardware and software complex was designed to allow control of the developed transducer. The eddy current transducer is the main element of the developed measuring system and is part of the hardware and software complex that controls the operation of the entire system. Its characteristics were calculated based on numerical modeling using the finite element method in the Elcut software package.

The main element of the eddy current method is the eddy current transducer, the design of which is selected for each specific task. Based on the results of mathematical modeling, the design of a transformer overhead high-current transformer has been developed, allowing the study of thin metal films. Figure 1 shows the design of the developed clamp-on transformer converter with a cone-shaped core made of ferrite.

The core is a truncated cone 4.3 mm high with a base diameter of 1.5 mm and apex diameter of 0.1 mm, Fig. 1a. The measuring winding is located at the tip of the cone (50 turns), the generator winding is located in the center (50 turns) and is wound in such a way that the radius is as small as possible to achieve maximum field localization. The windings are made of copper wire with a diameter of 15 microns.

To eliminate the influence of the generator winding on the measuring winding and increase the signal-to-noise ratio, a compensation winding was added to the ETP; the measuring and compensation windings are connected according to the differential circuit shown in Fig. 1b.

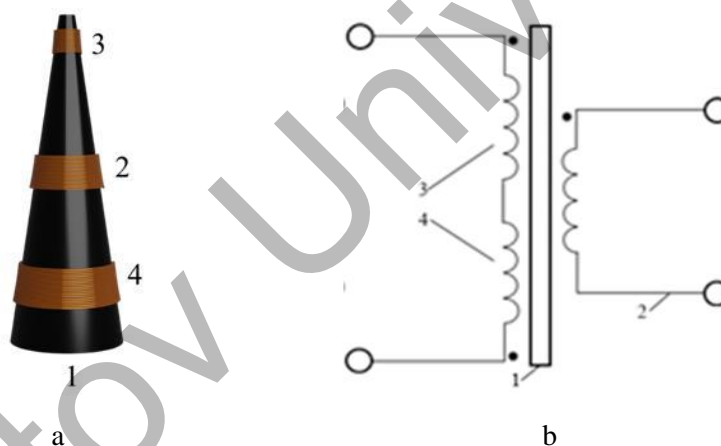

Fig.1. Design of the developed eddy- current transducer (ECT): a) 3D model, b) coil connection diagram: 1 – ferrite gearbox, 2 – generator winding, 3 – measuring winding, 4 – compensation winding

The transducer is positioned perpendicular to the plane of the film under study, so that the measuring winding is at a minimum distance from the surface of the film, but the ECP is not in contact with it.

To protect against mechanical damage, the converter is coated with epoxy resin and placed in a plastic case. To control the operation of the developed converter, automate the measurement process and convenient visualize the results obtained, a hardware and software complex is required. The main requirements for the hardware and software complex were the ability to position the ECP in increments of up to 0.01 mm, the accuracy and speed of data processing. Additional requirements included the portability of the complex and the ability to control it via a personal computer (PC).

The developed diagram of the software and hardware complex is presented in Fig. 2. The control unit, executed on the basis of a personal computer (PC), generates and sends commands to the generator (GEN) and the ECP positioning system. The generator, having received a control signal, generates an alternating electric current of a given frequency, which, passing through the Amplifier, acquires a given amplitude and is supplied to the exciting coil of the ECP. The voltage on the measuring coil, passing through the Amplifier and Filter, is supplied to an analog-to-digital converter and then, in the form of a digital signal, enters the processing and visualization unit PC.

To move the ECP over the object of study, a positioning system based on Cartesian kinematics, based on a Cartesian coordinate system, was developed; this technology operates on the basis of three axes - X, Y,

Z. The platform for securing the research object moves along the Y axis, and the sensor holder moves along the X and Z axis. Each direction has its own motor, the Y and X axes have a belt drive (Fig. 3), the Z axis is driven by a screw system consisting of a stepper motor, a flexible coupling and a screw, the pitch of which determines the step size along this axis.

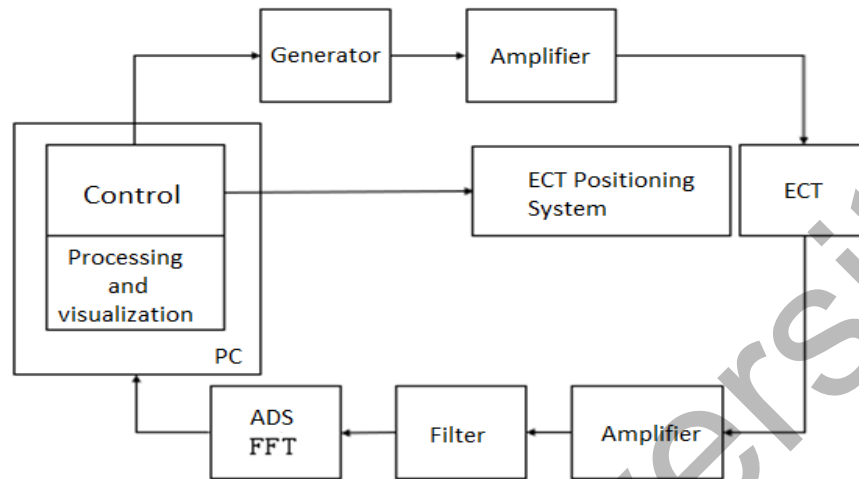

Fig.2. Scheme of the eddy current complex

The maximum size of the probing area is 22×22 cm, the maximum movement speed is 180 mm/s, the movement accuracy is 100 μm . Stepper motors are controlled using a motherboard with a 32-bit processor. The motherboard is equipped with a universal serial bus (USB) connector through which a connection is made to a PC for receiving control commands. The motherboard used has Marlin firmware and is controlled using commands in the G-cod programming language. On the positioning system, a sensor is placed in a special holder, which is an eddy current transducer that interacts with the object of study using the generated electromagnetic field.

To generate the electromagnetic field of the eddy current transducer, a system for generating signals supplied to the exciting winding of the eddy current transducer was developed. The software control of the generation system being developed is implemented in a hardware-software complex in the form of a generator made in the form of a module based on the AD9850 microcircuit. The module is a chip that uses a combination of advanced technology for direct digital synthesis (DDS), high-quality digital-to-analog conversion and a comparator, providing the functions of synthesizing a signal of a given frequency, generating clock signals designed for correct operation of the system and digital software management. When operated from an accurate reference clock source, the AD9850 produces a stable analog sine wave output with programmable frequency and phase.

The developed module has the following characteristics: with a clock generator frequency of 125 MHz, a sinusoidal signal with a frequency from 0 to 40 MHz can be obtained at the module output. The resulting signal is characterized by high stability, low noise level, and also requires a low supply voltage (from 3.3 V to 5 V). The module dimensions are 3*4 cm.

The disadvantages of this module include the lack of adjustment of the amplitude of the output signal and its low power. These shortcomings were mitigated by using an amplifier with adjustable gain. The generation module is controlled using the Arduino hardware computing platform. The platform consists of two main components: an I/O board and a development environment in the Processing/Wiring language.

The form factors of the Arduino microcircuit differ not only in appearance and the number of pins (inputs and outputs), but also in the presence of an installed microcontroller, a clock generator and the amount of flash memory and random access memory (RAM).

To digitize the ECT output signal, a module with a high sampling rate based on the RTL2832U chip was selected. The selected module directly includes an application delivery controller (ADC), a digital processor, a USB interface, and filters. Characteristics of the module on the RTL2832U chip:

- ADC capacity: 8 bits;
- Sampling rate 3.2 MS/s;

- Frequency band: 0.5-1750 MHz;
- Variable filter width;
- Sensitivity: 0.22 μV (at 438 MHz in network friendly mode (NFM) mode);

The selected signal digitization module allows you to obtain output signal values expressed in conventional units. To obtain the output signal amplitude values in volts, a calibration curve was constructed.

The resulting dependence is complex: for signal amplitudes up to 100 mV, the dependence is linear; for amplitudes above 100 mV, the dependence becomes nonlinear. To reduce the error, the ADC input amplifier is configured so that the signal amplitude does not exceed 100 mV, which will ensure operation of the ADC module in the region of linear dependence of the calibration dependence.

To control the operation of the hardware and software complex, process and visualize the obtained values, software was developed in Python, the graphical shell of the software was created in the Qt designer software package. The Python programming language was chosen due to its simplicity, versatility, relevance and availability of a large number of open-source libraries for data processing and visualization. In the working window of the developed software, the frequency of the exciting signal is set, the value of which is transmitted to the generator through the Serial Port library, the generator generates an exciting signal of a sinusoidal shape with a given frequency.

Further, in accordance with the installation diagram, in order to achieve the required amplitude value, the signal is sent to a special amplifier, the coefficient of which can vary within certain limits. The signal, which has undergone the amplification procedure, is fed to the excitation winding of the converter, as a result of which eddy currents are induced in the object of study. The resulting field induces an output signal in the electromagnetic field (EMF) measuring winding that carries information about the object of study. The output signal of the converter is amplified. After amplification, the signal is supplied to the block for collecting, digitizing and primary data processing, where voltage measurement and analog-to-digital conversion of the result occurs.

The resulting voltage values are transmitted via Serial Port to the PC. For this purpose, the class RTL (QThread) for reading data from the ADC module and primary data processing is used. While using the class, the ADC switches to discrete read mode using the command `<self.sdr.set_direct_sampling>` (direct_sampling), the command `<self.sdr.sample_rate = SampleRate>` the sampling frequency is set. The received data is transferred to the array with the command `<self.data = data>`. Next using the command `<fft = np.fft.rfft(samples)>` a fast direct discrete Fourier transform of the array is performed, the result is written to the array fft, having a complex appearance.

Calculation of signal component amplitudes ($\sqrt{Re^2 + Im^2}$) is performed using the abs function, the average amplitude value is also calculated and the resulting value is written to the output array. Next, the software presents the measured information from the sensor of the software and hardware complex in the form of an image of the signal amplitude distribution over the scanning area.

Fig.3 shows an example of presenting the result of scanning a research object in the form of a histogram: the measured values of the signal amplitude are plotted along the abscissa axis, and the number of points with a given amplitude is plotted along the ordinate axis.

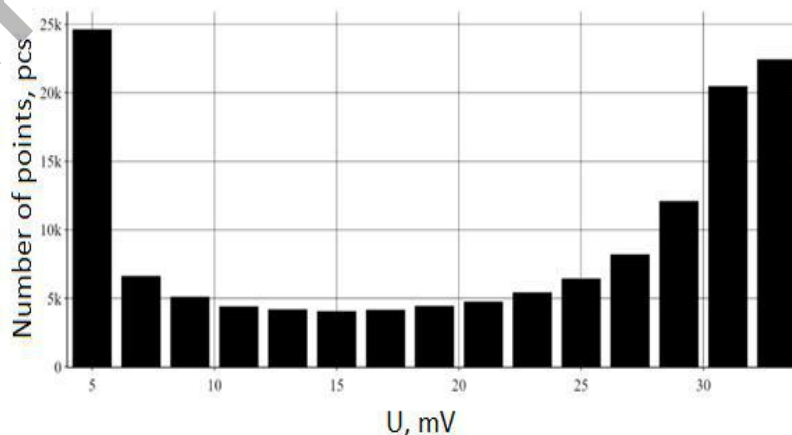

Fig.3. Graphic representation of the result of scanning the research object in the form of a histogram

This type of graphical representation allows one to assess the homogeneity of the object of study in terms of the height of the maxima and their area. Fig.4 (a) shows the results of scanning the research object in three-dimensional form. The coordinates of the sensor position above the object are plotted along the X and Y axes; the amplitude value of the transducer signal is plotted along the Z axis. Also, the signal amplitude values are expressed by the color of each point; on the right is a color line showing the correspondence of the point color to the signal amplitude value. This representation makes it possible to analyze the surface of an object.

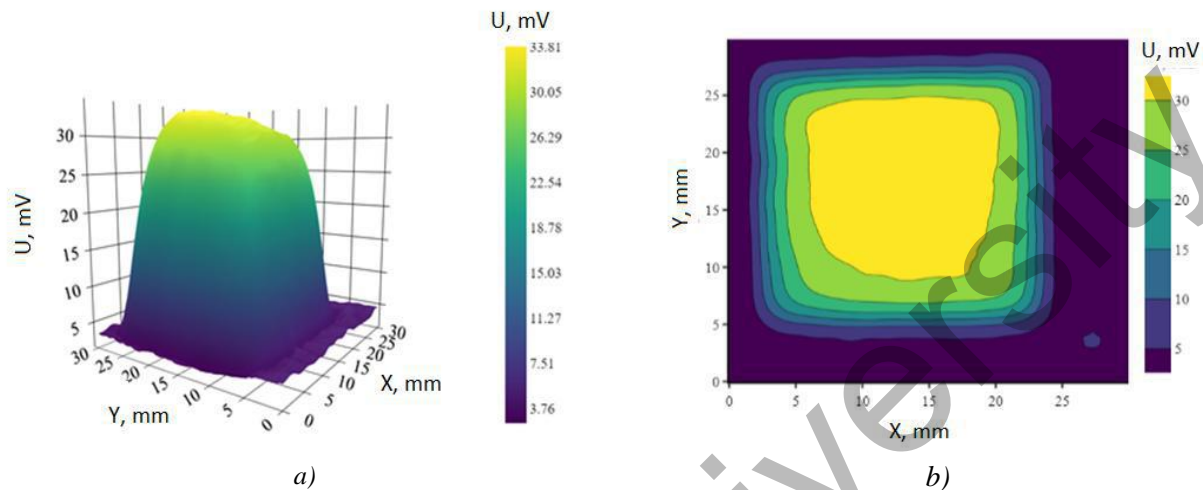

Fig. 4. Graphical representation of the result of scanning the research object in three-dimensional (a) and two-dimensional (b) form

Figure 4 (b) shows a graphical representation of the results of scanning the research object in two-dimensional form. Along the X and Y axes the coordinates of the sensor position above the object of study are plotted, the signal amplitude is encoded in the color of the point and a color ruler is provided to determine the amplitude by color, isolines are also drawn for convenient determination of the signal amplitude in individual areas. This graphical representation allows you to visually separate areas with different signal amplitudes and estimate the size of defects and inhomogeneities in these areas.

3. Results and discussion

In order to test the developed measuring system to assess the distribution of metal deposited on a glass substrate, samples of two thin copper films were scanned (Fig. 3, 4). By comparing the image data, it can be concluded that the sample data vary in homogeneity. The conclusion about the high homogeneity of sample No. 1 can be made from the size of the area of the region corresponding to the amplitude of the ETP signal $U > 25$ mV in Fig. 4 (b), 4 (a), and in Fig. 3 we can distinguish two regions with significant maxima of U , lying in the range from 0 to 5 mV and from 25 to 35 mV. The large area of the second region allows us to conclude that this sample is highly homogeneous.

Fig.5 shows the results of scanning the obtained batches of thin copper films. The film thickness ranged from 100 to 800 nm. The results obtained from scanning each batch of films demonstrate a different distribution of film heterogeneity within the same batch. During scanning of batch 1 (Fig. 5), it was found that the most homogeneous film is shown in Fig. 5 (b). The signal amplitude on this film remains constant over 90% of its area and has a value of about 30 mV. Fig.5 (a) shows a film with a defect, where in the defect area the amplitude of the ETP signal is 16 mV – 62% of the maximum amplitude of the ETP signal.

Analysis of the scanning results shows that the heterogeneity of the distribution of physical properties is observed not only within the boundaries of each film, but also within one batch of films. In each batch of films, it is possible to select a region corresponding to the maximum amplitude of the ETP signal and regions corresponding to a lower signal amplitude. The position of the maximum amplitude of the ETP signal on the graph can be associated with the position of the evaporated substance on the evaporator. The amplitude of the ETP signal is directly related to the position of the substrate relative to the deposited substance and increases when analyzing samples located closer to the deposited metal.

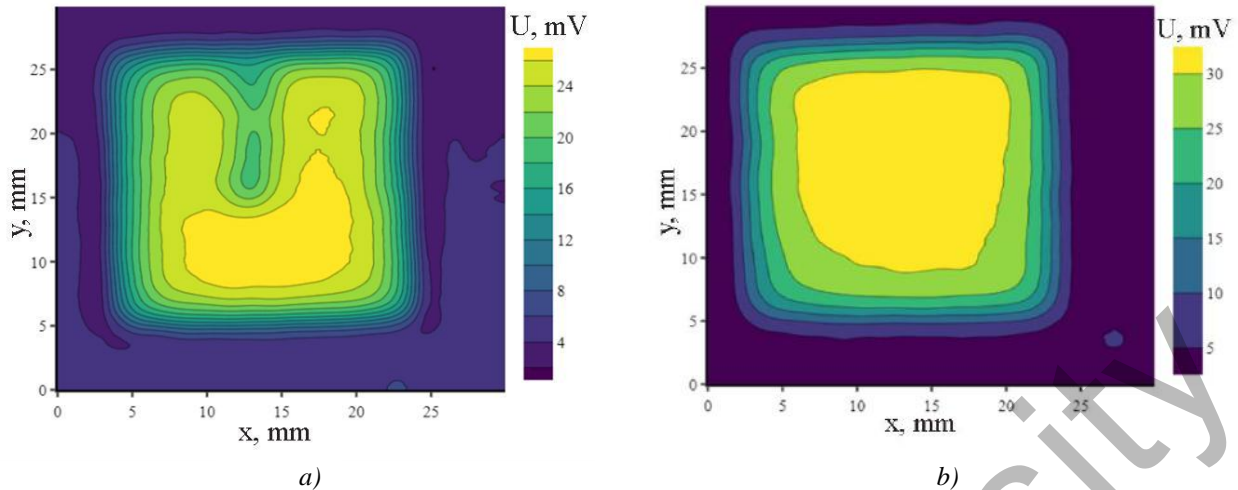

Fig. 5. Batch 1 scan results

To verify the results obtained from the analysis of the distribution of film inhomogeneities over the surface using the eddy current method, studies of the light transmission of the films were carried out. The laser beam with a wavelength of 650 nm was passed through the film, and the fraction of transmitted radiation was measured by a photoresistor. The image obtained as a result of measurements by the photometric method has significant visual similarity to the image obtained as a result of measurements by the eddy current method. To obtain a quantitative assessment of the degree of similarity of the images, Fig. 6 shows sections passing through identical areas of the film. The sections are shown with red lines.

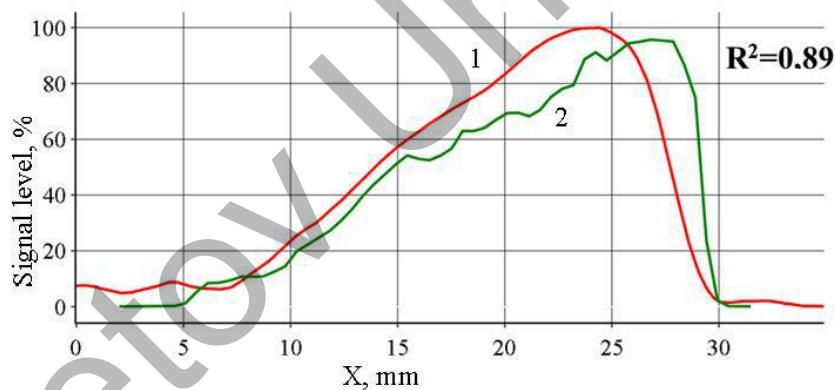

Fig. 6. Dependence of the signal level on the coordinate along the selected section:
1 – eddy current method, 2 – photometric method

The results obtained allow us to conclude that there is a high degree of correlation between the amplitude of the ETP signal and the attenuation coefficient of laser radiation by a thin film, which in turn is directly proportional to the thickness of the film. The correlation coefficient was 0.89.

4. Conclusion

Thus, scanning a significant number of metal films showed that the substance of the resulting films is not distributed uniformly over the surface of the substrate. A conclusion about the degree of homogeneity can be made from the size of the area of the region corresponding to the maximum of the signal. The larger the area occupied by the region corresponding to the maximum signal, the more homogeneous the film is. The dependence of the amplitude of the ETP signal on the film thickness was also determined. For films with a thickness from 100 to 500 nm and an electrical conductivity of 14 MS/m, the maximum signal amplitude ranged from 5.98 to 8.76 V, respectively. To verify the results obtained, studies of the light transmittance of the films were carried out using the photometric method. Comparison of the measurement results obtained by the two methods showed a high degree of agreement, the correlation coefficient R^2 was 0.89.

REFERENCES

- 1 Mansurov G.N., Petriy O.A. *Electrochemistry of thin metal films*. Moscow. 2011, 351 p. [in Russian]
- 2 Yurkov V., Ryzhii V. Effect of Coulomb scattering on graphene conductivity. *JETP Lett.*, 2008, Vol. 88, No. 5, pp. 370 – 373. doi:10.48550/arXiv.0807.3880
- 3 Khokhlov A. Novel highly elastic magnetic materials for dampers and seals: Part I. Preparation and characterization of the elastic materials. *Polym. Adv. Technol.*, 2007, Vol. 18, No 11, pp. 883 – 890. doi:10.1002/pat.924
- 4 Kosobudskii I. Nanocomposites based on the cerium oxide nanoparticles and polyethylene matrix: Syntheses and properties. *Acta Mater.*, 2008, Vol. 56, No.10, pp. 2336-2343. doi:10.1016/j.actamat.2008.01.019
- 5 Borodina I. Influence of conducting layer and conducting electrode on acoustic waves propagating in potassium niobate plates. *IEEE Trans. on Ultrason. Ferroelectrics. and Freq. Cont.*, 2001, Vol. 48, No 2, pp. 624-626. doi:10.1109/58.911747
- 6 Whiteside P., Chininis J., Hunt H. Techniques and Challenges for Characterizing Metal Thin Films with Applications in Photonics. *Coat*, 2016, Vol. 6, No.3. doi:10.3390/coatings6030035
- 7 Wang Z., Han Y., Xu N. Characterization of Thin Metal Films Using Terahertz Spectroscopy. *IEEE Trans. Terah. Sci. Tech.*, 2018, Vol. 99, pp.1-4. doi:10.1109/TTHZ.2017.2786692
- 8 Giurlani W., Berretti E. Measuring the Thickness of Metal Films: A Selection Guide to the Most Suitable Technique. *Mater. Proc.*, 2020, Vol. 2, No. 1, pp. 12-35. doi:10.3390/CIWC2020-06823
- 9 Lu X. In-situ measurement of Cu film thickness during the CMP process by using eddy current method alone. *Microelectronic Engineering*, 2013, Vol. 108, pp. 66-70. doi:10.1016/j.mee.2013.03.046
- 10 Zheng Y. Noncontact thickness measurement of cu film on silicon wafer using magnetic resonance coupling for stress free polishing application. *IEEE Access*, 2019, Vol. 7, pp. 75330-75341. doi:10.1109/ACCESS.2019.2921005
- 11 García-Martín J., Gómez-Gil J., Vázquez-Sánchez E. Non-destructive techniques based on eddy current testing. *Sensors*, 2011, Vol. 11, No. 3, pp. 2525–2565. doi:10.3390/s110302525
- 12 Krause T.W. Simultaneous multiparameter measurement in pulsed eddy current steam generator data using artificial neural networks. *IEEE Trans. Instrum. Meas.*, 2016, Vol. 65, No. 3, pp. 672-679. doi:10.1109/TIM.2016.2514778
- 13 Pasadas D.J. Inspection of cracks in aluminum multilayer structures using planar ECT probe and inversion problem. *IEEE Trans. Instrum. Meas.*, 2017, Vol. 66, No. 5, pp. 920–927. doi:10.1109/TIM.2017.2682758
- 14 Bernieri A. Multifrequency excitation and support vector machine regressor for ECT defect characterization. *IEEE Trans. Instrum. Meas.*, 2014, Vol. 63, No. 5, pp. 1272–1280. doi:10.1109/TIM.2013.2292326
- 15 Wang H., Li W., Feng Z. Noncontact thickness measurement of metal films using eddy-current sensors immune to distance variation. *IEEE Trans. Instrum. Meas.*, 2015, Vol. 64, No. 9, pp. 2557–2564. doi:10.1109/TIM.2015.2406053
- 16 Yang H.-C., Tai C.-C. Pulsed eddy-current measurement of a conducting coating on a magnetic metal plate. *Meas. Sci. Technol.*, 2002, Vol. 13, No. 8, pp. 1259–1265. doi:10.1088/0957-0233/13/8/313
- 17 Danon Y., Lee C., Mulligan C., Vigilante G. Characterizing tantalum sputtered coatings on steel by using eddy currents, *IEEE Trans. Magn.*, 2004, Vol.40, No.4, pp. 1826-1832. doi:10.1109/TMAG.2004.828040
- 18 Ishkov A., Malikov V., Dmitriev S. Scanning steel junctions using eddy current probe. *J. Phys.: Conf. Ser.*, 2021, Vol. 1728. doi:10.1088/1742-6596/1728/1/012007
- 19 Bowler J.R., Norton S.J. Eddy current inversion for layered conductors. *Res. Nondestr. Eval.*, 1992, Vol. 4, No. 4, pp. 205–219. doi:10.1007/BF01616488
- 20 Moulder J.C., Uzal E., Rose J.H. Thickness and conductivity of metallic layers from eddy current measurements. *Rev. Sci. Instrum.*, 1992, Vol. 63, No. 6, pp. 3455–3465. doi:10.1063/1.1143749
- 21 Ping-jie H., Zhao-tong W. Inversion of thicknesses of multi-layered structures from eddy current testing measurements. *J. Zhejiang Univ. Sci.*, 2004, Vol. 5, No. 1, pp. 86-91. doi:10.1007/BF02839318
- 22 Li Y., Chen Z., Mao Y., Qi Y. Quantitative evaluation of thermal barrier coating based on eddy current technique. *NDT&E Int.*, 2012, Vol. 50, pp. 29–35. doi:10.1016/j.ndteint.2012.04.006
- 23 Li Y., Yan, B., Li W., Li D. Thickness assessment of thermal barrier coatings of aeroengine blades via dual-frequency eddy current evaluation. *IEEE Magn. Lett.*, 2016, Vol. 7, pp. 1304905. doi:10.1109/LMAG.2016.2590465
- 24 Sethuraman A., Rose J.H. Rapid inversion of eddy current data for conductivity and thickness of metal coatings. *J. Nondestruct. Eval.*, 1995, Vol. 14, No. 1, pp. 39–46. doi:10.1007/BF00735670
- 25 Tai C.-C., Rose J.H., Moulder J.C. Thickness and conductivity of metallic layers from pulsed eddy-current measurements. *Rev. Sci. Instrum.*, 1996, Vol. 67, No. 11, pp. 3965–3972. doi:10.1063/1.1147300
- 26 Zhang D., Yu Y., Lai C., Tian G. Thickness measurement of multi-layer conductive coatings using multifrequency eddy current techniques. *Nondestruct. Test. Eval.*, 2016, Vol. 31, No. 3, pp. 191–208. doi:10.1080/10589759.2015.1081903

27 Yu Y., Zhang D., Lai C., Tian G. Quantitative approach for thickness and conductivity measurement of monolayer coating by dual-frequency eddy current technique. *IEEE Trans. Instrum. Meas.*, 2017, Vol. 66, No. 7, pp. 1874–1882. doi:10.1109/TIM.2017.2669843

28 Katasonov A.O., Malikov V.N., Dmitriev S.F. Scanning the thickness of conductive and dielectric coatings using superminiature eddy current probe. *Lecture Notes in Civil Eng.*, 2021, Vol. 130. pp. 548 – 554. doi:10.1007/978-981-33-6208-6_54

29 Malikov V.N., Fadeev D.A., Dmitriev S.F. Study of surface and electrical conductivity of thin metal films of the Ni-Al system. *Nanobiotechnology reports*, 2021. Vol. 16. No. 2. pp. 261 – 265. doi:10.1134/S2635167621020051

30 Ishkov A.V., Malikov V.N., Sagalakov A.M. Subminiature eddy current transducers for thickness measurement problems. *Journal of Machinery Manufacture and Reliability*, 2020, Vol. 49, No. 9, pp. 783 – 786. doi:10.3103/S105261882009006X

31 Ishkov A.V., Malikov V.N., Sagalakov A.M. Subminiature eddy-current transducers for conductive materials and layered composites research. *Advances in Intelligent Systems and Computing*, 2018, No. 692, pp. 655 – 665. doi:10.1007/978-3-319-70987-1_70

Article received 19.10.2023

Article accepted 18.12.2023

Buketov University