

## ENHANCEMENT OF STEAM-TURBINE CONDENSER STEAM-JET EJECTOR

Shavdinova M.D.\*, Sharipov R.Zh., Meshherjakova T.Y.

Kazakh-German University in Almaty, Almaty, Kazakhstan, shavdinova@dku.kz

*A three-stage steam-jet ejector EPO-3-200 with a working steam flow rate of 850 t / h is installed at the Combined Heat and Power Plant-2 of the city of Almaty on heating turbines. In this paper, the replacement of the existing three-stage steam-jet ejector with a two-stage steam-jet ejector is proposed and substantiated. As a result of the replacement, they obtained a saving of heat (steam) for their own needs for the production of electrical energy. It has been established that at a pressure in the turbine condenser significantly lower than 100 kPa, it is advisable to install a new two-stage ejector EPO-2-80 instead of EPO-3-200. Using the existing calculation methods, the geometric characteristics of the new ejector were obtained. The working steam flow rate of the new two-stage ejector is 579 t / h. In addition, the use of two stages makes it possible to simplify the design and make it more reliable, and also makes it possible to increase the pressure in the cooler of the 1st stage of the ejector. This is especially important for cogeneration turbines, which may have a high temperature of the main condensate, which adversely affects the performance of a conventional three-stage ejector.*

**Keywords:** steam-jet ejector, raising of efficiency, three-stage ejector, two-stage ejector, cooler, mathematical model, steam turbine.

### Introduction

Steam jet ejectors are designed to remove air from condenser and vacuum system; they are among the most important technical components of condensing systems [1]. We know steam jet multistage ejectors of various manufacturers (Leningrad Metal Plant (LMP), Ural Turbine Works (UTW), Kharkiv Turbine Plant (KhTP), Kaluga Turbine Works (KTW)), such as EP-3-700, EP-3-3, EP-3-25/75 and others consisting of three stages each of which contains a nozzle, a receiving chamber, a diffuser and a cooler [2].

We know a steam jet ejector with external coolers – an equivalent of EPO-3-135 developed by the UTW, with "external tube bundle" coolers [3]. This ejector solves the main problem of multistage steam jet ejectors associated with inter-stage vapor-air mixture (VAM) leakages. Based on the analysis of experimental characteristics of multi-stage steam-jet ejectors of steam turbines, a set of questions was framed to refine the physical model of gas dynamics in the flow path of steam-jet device and the calculation method for ejectors, as well as the performance features of intermediate coolers. It has been established that the cooler efficiency depends on the steam pressure which is determined by the operation of steam jet ejector on the steam jet stage following after the cooler, the temperature and the cooling water flow rate. The steam contained in the air-vapor mixture entering the cooler is generally overheated relative to the saturation temperature of the mixture steam. This is to be taken into account when calculating the cooler. Long-term operation changes the roughness of walls in the ejector mixing chamber. The effect of such change in the wall roughness on the ejector characteristic is similar to that of the back pressure of steam jet stage. Up to a certain value of roughness, the injection factor of ejector stage operating out-of-limit remains practically unchanged. When critical roughness is reached, the ejector switches to pre-limiting operating mode [4].

The developed and approved design solutions were presented [4] that allow to enhance the ejector performance. Coolers are designed in separate bodies, so the vapor-air mixture cannot move from high-pressure zones to low-pressure zones and the maintainability of the units increases. The U-type pipes compensate for the expansion effect of intercooler pipes and increase the heat exchange area.

In [5-8], the axial position of ejector nozzle was analyzed. The studies mentioned were carried out for various substances used as working and entrained flows, but not for water and water steam. In [9] the ejector structural design was analyzed. In many cases, ejectors are designed quite empirically, and the main flow sections are the only elements of ejector geometry that require design force. Some other elements, such as the length of mixing zone or the secondary flow inlet angle, are left to a designer's discretion. A design was proposed that takes into account the effect of a rim between conical and cylindrical parts. The authors of the

paper [10] have made the model of steam jet ejector, and then carried out CFD analysis for its geometry. The inlet status data was verified by evaluating the performance of jet ejector to find the entrainment factor which was then compared to the experimental data.

Adriano Milazzo and Federico Mazzelli have developed CFD (ANSYS Fluent) model of ejector using the user defined functions. The scheme is based on a single liquid approach and solves the transfer equations for a uniform mixture combined with the conservation equations for a number of droplets and volume ratio of liquid. The model is checked for compliance with a test version of the steam nozzle, and then compared to experimental data of the steam ejector with a significant volume of resulting liquid phase. The simulation showed a good ratio, both in terms of mass flow rates and pressure profile data [11]. In [12], a CFD model of ejector was also developed and an experimental test was carried out in a wide range of operating conditions for various configurations of the ejector. The study results show that the length of pseudo-shock has a dominant influence on the entrainment characteristics and geometry optimization. A significant difference in the length of the pseudo-shock for gas and gas-liquid ejectors was noted. This is due to the fact that the similarity of viscosity differs markedly in the range of 0.01–1.0, depending on the used primary and secondary fluids. Therefore, the optimal ‘mixing tube length/diameter’ ratio is approximately 1:2 for conventional gas-liquid ejectors and 5:7 for gas ejectors. The article [13] presents a mathematical model describing the flow inside a real ejector. Comparison of calculations with measurements is more than acceptable, and this method seems to be suitable for similar devices with converging nozzle. An ejector with different diameters of neck and diffuser can be used to create a new ejector with an increased airflow.

The authors of [14] propose a procedure for optimizing the ejector without taking into account the region of mixed supersonic flow, and constructs the design curves taking into account the constant ratios of general temperature, molecular weight and specific heat. In some applications involving high temperature gases, such as gas turbine facilities, an annular supersonic ejector is more appropriate where annular injection of the motive gas at the periphery of the flow passage is desired to avoid the exposure of the motive gas flow nozzle to the high temperature combustion product gases. The design and optimization procedure for an annular supersonic ejector was developed based on a simplified one-dimensional mixing of a constant model area and checked using CFD Fluent software.

In [15] the ejector is designed using CRMC method. CRMC ejector provides higher entrainment factor with the same critical condenser pressure. On the other hand, with the same entrainment ratio, CRMC ejector can operate at a higher critical condenser pressure. This confirms that the CRMC method improved the performance of the ejector. A new highly efficient ejector with external coolers EPO-3-80 was calculated, designed, manufactured and installed at TPP. Experimental studies of the developed ejector were conducted. Industrial testing was carried out for 1.5 years. Currently, EPO-3-80 ejector is successfully operating as part of a turbine unit with K200-130 turbine of LMP RF. The author has carried out a comparative analysis of the characteristics of serial ejectors and a new ejector. It follows from the analysis that the performance (length of operating characteristic) of new EPO-3-80 ejector is higher than that of serial ejectors. The suction pressure of the new ejector at low air flow rates is also minimal as compared to serial ejectors [4].

In [16], the ejector performance map is developed. The proposed ejector performance map can be used in numerical analysis of the ejector system to study the architectures of new cycles based on the ejector experimental data, thus increasing the accuracy of the system model. This can also help the system design engineers in making decisions on choosing the ejector system after careful analysis of system performance.

EPO-3-120 ejector is the closest to the new model in terms of its technical essence, its design corresponds to the utility model patent [17]. The known steam jet ejector is three-stage and includes nozzles, receiving chambers, mixing chambers, diffusers, reducing pipes and coolers located in each stage in a successive order along the path of motive steam. The nozzles are designed with a possibility of axial movement relative to the diffuser. The reducing pipes are located below diffusers. The ejector coolers are vertical and external, with U-shaped tubes. The coolers are triangular to each other, with equal body diameters. This engineering solution aims at increasing the reliability and efficiency of steam-jet ejectors for suction of non-condensable gases from the inner space of condensers of steam-turbine cogeneration plants (SCP) by reducing the total compression ratio of vapor-air mixture and the consumption of motive steam. The technical result achieved by the new model of ejector is decreased heat consumption for own needs of steam-turbine cogeneration plant (SCP).

The object under consideration is the cogeneration turbine T-100 / 120-130-3 of the Combined Heat and Power Plant-2 of the city of Almaty. The barometric pressure at the station is approximately 100 kPa. The

turbine is equipped with a three-stage steam-jet ejector EPO 3-200. It is necessary to replace the three-stage ejector with a two-stage one.

Thus, we obtain a simple and reliable design of a steam jet ejector for suction of non-condensable gases from steam turbine condensers of heating plants operating at barometric pressure below normal values ( $B \approx 100$  kPa). Allowing to reduce the total compression ratio of the steam-air mixture and the consumption of working steam, as well as to reduce the heat consumption for the auxiliary needs of a steam turbine cogeneration plant (STU), due to the use of two steam jet stages and the installation of intermediate baffles with sealing elements in the first stage cooler, which ensures high efficiency cogeneration turbine plant.

## 2. Materials and methods

Calculations were made for the first stages of existing three-stage steam-jet ejector EPO-3-200 and the new two-stage steam-jet ejector EPO-2-80 (Table 1). The initial data for calculation: motive steam pressure  $p_0 = 490$  kPa, motive steam temperature  $T_0 = 157$  °C, condenser pressure  $p_k = 7$  kPa obtained from the calculation according to the developed mathematical model of condenser [18], inlet circulating water temperature  $t_{1w} = 22.5$  °C, geometrical characteristics of ejector. The calculation was carried out using the method described in [19], [20]. The Table 2 shows the geometric characteristics of the new ejector.

**Table 1.** Calculation of the 1-st stages of steam-jet ejectors EPO-3-200 and EPO-2-80

Item No.	Parameter	Designation	Unit	Value	
				EPO-3-200	EPO-2-80
1	Pressure in receiving chamber $P_s = p_k \cdot 0.92$ [20]	$P_s$	Pa	6440	6440
2	Pressure of mixture $p_d = P_s \cdot \varepsilon$	$p_d$	Pa	141680	225760
3	Compression ratio	$\varepsilon$	-	22	4.0
4	Ejector volumetric efficiency $V_n = G_{air}(t_s + 273.15) \frac{R_{air}}{(p_s - p_{va}) \cdot 1000}$ [20]	$V_n$	m <sup>3</sup> /h	8569	6406
5	Motive steam consumption $G_s = G_w + G_{vam}$	$G_s$	kg/h	519	400
6	Steam consumption in VAM $G_{vam} = \frac{p_{vam} V_n}{R_s (t_s + 273.15)}$ [20]	$G_{vam}$	kg/h	261	241
7	Injection factor $u = \left( \mu \frac{F_3}{F_{cr}} - \frac{1}{q_{va}} \right) \frac{k_{air} \Pi_{air^*} a_s p_{air}}{k_s \Pi_{s^*} a_n p_s}$ [20]	$u$	-	0.8	0.80
8	Heat exchanger outlet mixture temperature $t_{mix} = (t_s(p_k)) \cdot 0.7 + t_{1w} \cdot 0.3$ [20]	$t_{mix}$	°C	46	46
9	The amount of steam condensed by the heat exchanger	$G_{s,HE}$	kg/h	189	208

Figure 1 shows that the curve of the new ejector is lower. The new ejector will help maintain a deeper vacuum on the turbine. Figure 2 shows the curve of the 1st stage of ejector sucking off the vapor-air mixture, depending on the temperature of mixture  $t_{mix}$ . The curve of the ejector sucking dry air or vapor-air mixture at a certain temperature has two different sections. The first section (ab), to a certain section  $G_B^*$ , is called a working section, this is comparatively flat. The second section (bc),  $G_B > G_B^*$ , is called a shifting section, this is much steeper. Air flow rate  $G_B^*$  is called a maximum operating capacity. The maximum operating capacity is different in dry air and vapor-air mixture of a certain temperature. For example, for section ab  $G_B^* = 100$  t/h. Resulting from calculations, the curves  $P_{sp} = f(G_{air})$  of the 1st ejector stage are plotted for "dry" air (Fig.1) and for ejector sucking off the vapor-air mixture (Fig.2). Also, the calculation results can establish the dependence of the injection factor  $u$  on the distance from nozzle exit section to mixing chamber inlet section  $l_{ck}$  (Fig.3). Figure 3 shows that the optimal injection factor for the first ejector stage will be  $u = 0.8$ .

**Table 2.** Geometrical dimensions of the new ejector EPO-2-80

Item No.	Parameter	Designation	Unit	Value	
				1 stage	2 stage
1	Nozzle throat diameter $d_{cr} = \sqrt{\frac{4G_s a_s}{3600 k_s \cdot \Pi_s \cdot p_s \cdot 10^6 \cdot 3.14}} [20]$	$d_{cr}$	mm	13.9	9.3
2	Nozzle exit diameter $d_c = \sqrt{\frac{d_{cr}}{q_{va}}} [20]$	$d_c$	mm	39.2	16.4
4	Diameter of the mixing chamber cylindrical section $d_{cyl} = d_{cr} \left(\frac{F_3}{F_{cr}}\right)^{0.5} [20]$	$d_{cyl}$	mm	109.1	29.1
5	Length of exit, conical section of nozzle $L_c = \frac{d_2 - d_3}{2tg(6^\circ)} [20]$	$L_c$	mm	120	34
6	Distance from nozzle exit section to mixing chamber inlet section $L_{ck} = \frac{55.79d_3}{12.64 + d_3/(d_{cr} \cdot 2)} - L_{con} - L_c [20]$	$L_{ck}$	mm	131	40
7	Length of the mixing chamber cylindrical section $L_{cyl} = 5d_3$	$L_{cyl}$	mm	546	146
8	Length of diffuser $L_d = \frac{d_4 - d_3}{2tg(4^\circ)} [20]$	$L_d$	mm	186	75

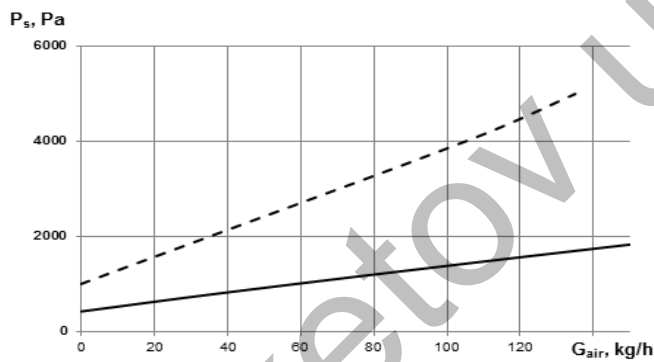
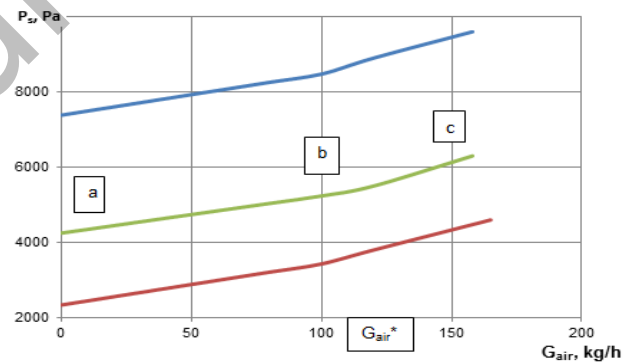
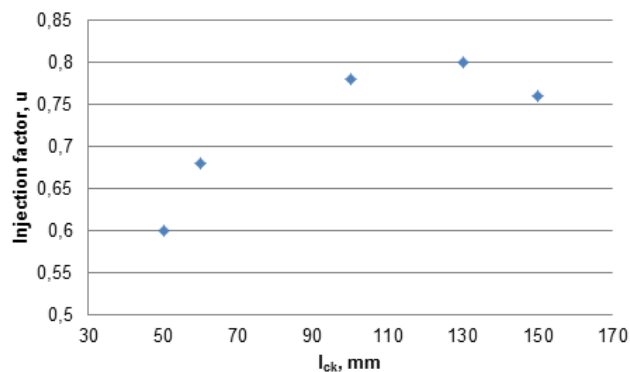
**Fig.1.** Curve of the 1-st ejector stage for "dry" air:  
— new ejector, - - - existing ejector**Fig.2.** Curve of the 1st ejector stage EPO-2-80 for ejector sucking off the vapor-air mixture—  $t_{mix}=30C$  —  $t_{mix}=40C$  —  $t_{mix}=20C$ **Fig.3.** The dependence of the injection factor on the distance from nozzle exit section to mixing chamber inlet section for ejector EPO-2-80

### 3. Results and discussion

Analysis of the operation data on operating modes of turbine T-100/120-130 at Almaty Thermal Power Plant-2 for 2020 showed that the steam pressure in the turbine condenser was higher than 7 kPa for much of the year. At the same time, barometric pressure is 92...93 kPa. For such process parameters, the main ejector was developed which differs from the rated (serial) ejector of T-100/120-130 turbine (EP-3-2 or EPO-3-200) in a number of characteristics. The new ejector is two-stage, the motive steam consumption per ejector is 579 kg/h, in contrast to the serial one with steam consumption of 850 kg/h.

The proposed EPO-2-80 steam jet ejector is a series-connected nozzle located in the direction of movement of the working steam in the corresponding casings of the steam jet stages, communicated with the receiving chamber, which is connected to the mixing chamber, a diffuser located below and communicated with the mixing chamber, a transition pipe, which on the one hand it is connected to the diffuser, and on the other hand it is connected to the shell-and-tube cooler. The cooler is made remote in a vertically located housing, inside of which U-shaped heat exchange tubes are located, characterized in that it contains two steam jet stages, the bodies of which are located vertically. The cooler of the first steam-jet stage and the cooler of the second steam-jet stage are connected in series through the cooling water. Condensate is supplied to the water chamber of the first stage cooler, and the condensate is removed from the water chamber of the second steam jet cooler. The calculations resulted in a two-stage steam-jet ejector EPO-2-80 (Fig. 4).

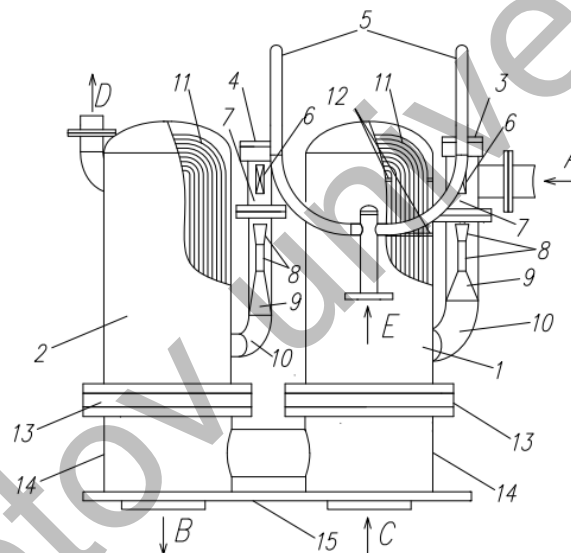

**Fig.4.** Steam-jet ejector EPO-2-80:

A - steam-air mixture supply, B - cooling water outlet, C - cooling water supply, D - air exhaust, E - working steam supply, 1 - first stage cooler, 2 - second stage cooler, 3 - first steam jet, 4 - second steam jet, 5 - steam line, 6 - working nozzle, 7 - receiving chamber, 8 - mixing chamber, 9 - diffuser, 10 - reducer, 11 - U-shaped tubes, 12 - intermediate partitions, 13 - tube sheet, 14 - water chamber, 15 - support frame

The new steam-jet ejector is distinguished by its intermediate baffles made in an annular shape; sealing elements are made as sealing collars; sealing elements are made of fluoro plastic; sealing elements are fixed along the outer diameter over total circumference of the annular intermediate baffle; the sealing elements are bolted to the intermediate baffles and fitted with a metal base.

The technical and economic effect of the new ejector was assessed in comparison with the serial one. This effect consists in saving heat (steam) of own needs for electrical energy production. According to the operation data of Almaty Thermal Power Plant-2, motive steam is supplied to the main ejectors of T-100/110-130 turbine from the general station steam collector at 1.3 MPa. Steam is supplied to this collector from the production extraction of turbine PT-80/100-130/13 or ROU 130/13. The new main ejector will reduce the steam consumption by 271 kg/h as compared to the serial ejector.

When the steam from extraction of PT-80/100-130/13 turbine is supplied to the collector, the new ejector consumes less steam heat by 168 kW (0.144 Gcal/h). Then PT-80/100-130/13 turbine can generate 43.2 kW of extra power by saving steam for the main ejector of T-100/120-130 turbine. Thus, thanks to the new ejector, we saved 84 tons of oil equivalent (t.f.e).

If live steam enters the general station collector, then the savings from the new ejector can be calculated based on the characteristic of PT-80/100-130/13 turbine in condensing mode. Savings from the new ejector will be 70.6 kW. The new ejector will save 137 tons of oil equivalent (t.o.e.). The effect obtained does not take into account the increase in turbine power due to a very likely decrease in condenser steam pressure (deepening of vacuum) with a new ejector installed which has a higher volumetric efficiency as compared to serial ejectors. Vacuum deepens at partial steam flows in the condenser and increased air inflows in the vacuum system in excess of the standard values. The presented analysis was performed without taking into account the cost of ejector replacement. To assess the effectiveness of the project for modernization of T-100/120-130 turbine at Almaty Thermal Power Plant-2, a feasibility study is necessary.

The new two-stage steam-jet ejector is designed for exhaust air compression ratio  $\varepsilon = 3.5 \dots 4.0$ . Comparison of the new model with the prototype reveals the following distinctive features:

- two steam-jet stages;
- vertically arranged bodies of two steam-jet stages;
- the cooler of the first steam-jet stage and the cooler of the second steam-jet stage are connected in series through cooling water.

Distinctive features of the proposed utility model allow to conclude that it meets the "novelty" criterion. The new steam jet ejector is made of materials known in the industry, structural units and parts, which are connected into a single structure by assembly operations and are in a structural unity. All this ensures the achievement of a technical result. This allows conclude the proposed model meets the criterion of "industrial applicability".

## Conclusion

To save steam for own needs, it was proposed to replace the existing three-stage steam-jet ejector at Almaty Thermal Power Plant-2 with a two-stage ejector. Calculations were carried out for the 1st stage of the existing three-stage ejector EPO-3-200 and two-stage ejector EPO-280. Geometric characteristics of the new ejector were obtained. The curve of the 1-st ejector stage for "dry" air was plotted. The curve of the new ejector is lower; this ejector will probably maintain a deeper vacuum on the turbine. The curve is plotted for the 1st stage of ejector sucking off the vapor-air mixture, depending on the temperature of mixture  $t_{\text{mix}}$ .

The dependence of the injection factor on the distance from nozzle exit section to mixing chamber inlet section was plotted. The optimal injection factor for the first ejector stage will be  $u = 0.8$ . The advantage of the new model is that, with the same productivity for exhaust dry air, the analogue and the existing ejector consume 1.5 times more motive steam than the declared design.

In the proposed design of the new ejector, the steam pressure in the first-stage cooler is higher than in the existing and existing ejectors, which makes it possible to reliably operate the ejector at condensate temperatures 10 ... 15 °C higher than the existing and existing ejectors.

A utility model patent for a two-stage steam jet ejector was obtained. The technical and economic effect of the new ejector was assessed in comparison with the existing one. The new main ejector will reduce the steam consumption by 271 kg/h as compared to the serial ejector. When the steam from extraction of PT-80/100-130/13 turbine is supplied to the collector, the new ejector consumes less steam heat by 168 kW. In this case, the new ejector will save 84 tons of oil equivalent (toe).

If live steam enters the general station collector, then the savings from the new ejector can be calculated based on the characteristic of PT-80/100-130/13 turbine in condensing mode. In this case, the new ejector will save 137 tons of oil equivalent (toe). To assess the effectiveness of the project for modernization of T-100/120-130 turbine at Almaty Thermal Power Plant-2, a feasibility study is necessary.

## REFERENCES

- 1 Ryabchikov A.Yu., Aronson K. É., Brodov Yu. M., et al. Increasing the reliability of steam-jet ejectors in power plant turbines. *Power Technology and Engineering*. 2017, Vol. 50, No. 5. DOI: 10.1007/s10749-017-0748-5
- 2 Belevich, A.I. RD 34.30.302-87: *Methodical Guidelines on adjustment and operation of steam-jet ejectors of turbine condensing plants at TPP and NPP*. M. Ministry of Energy of the USSR, 1990, 34 p. [in Russian]
- 3 Barinberg, G. D. *Steam turbines and turbine plants of the Ural Turbine Works*. Yekaterinburg, 2007, 460 p.
- 4 Aronson K. É., Ryabchikov A.Yu., Kuptsov V.K., et al. Ejectors of power plants turbine units efficiency and reliability increasing. *IOP Conf. Series 891: Journal of Physics*. 2017, pp. 104 – 110. DOI:10.1088/1742-6596/891/1/012249

- 5 Fan, J., Eves, J., Thompso, H.M., et al. Computational fluid dynamic analysis and design optimization of jet pumps. *Computers & Fluids*. 2011, Vol. 46, pp. 212–217
- 6 Ruangtrakoon N., Aphornratana S., Sriveerakul T. Experimental studies of a steam jet refrigeration cycle: Effect of the primary nozzle geometries to system performance. *Experimental Thermal and Fluid Science*. 2011, Vol. 35, pp. 676–683. DOI:10.1016/j.expthermflusci.2011.01.001
- 7 Szabolcs V., Oliveira A.C., Ma X., et al. Experimental and numerical analysis of a variable area ratio steam ejector. *International Journal of Refrigeration*. 2011, Vol. 34, No 7, pp. 255 – 262. DOI:10.1016/j.ijrefrig.2010.12.020
- 8 Narmine H.A., Karameldin A., Shamloul M.M., et al. Modelling and simulation of steam jet ejectors. *Desalination*. 1999, Vol. 123, pp. 1-8.
- 9 Grazzini G., Milazzo A., Mazzelli F. Ejector Design. *Ejectors for Efficient Refrigeration*. 2018, pp.71-115 DOI:10.1007/978-3-319-75244-0\_3
- 10 Singhal A., Chitkara T., Ameenuddin M. CFD Analysis and Performance Evaluation of the Steam Jet Ejector. *National Convention of Aerospace Engineers*. University of Petroleum & Energy Studies. Dehradun, India. 2013, p. 3.
- 11 Mazzelli F., Giacomelli F., Milazzo A. CFD modeling of condensing steam ejectors: Comparison with an experimental test-case. *International Journal of Thermal Sciences*. 2018, Vol. 127, pp. 7 – 18. DOI: 10.1016/j.ijthermalsci.2018.01.012
- 12 Li C., Li Y., Wang L. Configuration dependence and optimization of the entrainment performance for gasegas and gaseliquid ejectors. *Applied Thermal Engineering*. 2012, Vol. 48, pp. 237-248.
- 13 Jakub A. *Mathematical model of ejector and experimental verification*. Setkani kateder mechaniky tekutin a termomechaniky, Mikulov, 2012, pp. 26. – 28. [in Czech]
- 14 Sathiyamoorthy K., Iyengar V.S., Pulumathi M. Annular Supersonic Ejector Design and Optimization. *ASME 2012 Gas Turbine India Conference*. 2012, pp. 212-219. DOI:10.1115/GTINDIA2012-9547
- 15 Kittrattanaa B., Aphornratanaa S., Thongtipb T. Comparison of traditional and CRMC ejector performance used in a steamejector refrigeration. *Energy Procedia*. 2017, Vol. 138, pp. 476 – 481.
- 16 Haider M., Elbel S. Development of Ejector Performance Map for Predicting Fixed-geometry Two-phase Ejector Performance for Wide Range of Operating Conditions. *International Journal of Refrigeration*. 2021, pp. 456-483. DOI:10.1016/j.ijrefrig.2021.03.022
- 17 Brodov, Yu. M., Kuptsov, V. K., Ryabchikov, A. Yu., et al. *Patent for steam-jet three-stage ejector*. RU170935. 2016119824. Publ. 2016.05.23, 9 p. [in Russian]
- 18 Shavdinova M., Aronson K., Borissova N. Development of condenser mathematical model for research and development of ways to improve its efficiency. *Journal of Applied Engineering Science*. 2020, Vol. 18, pp. 578 – 585 DOI: 10.5937/jaes0-27517
- 19 Aronson, K. E., Ryabchikov, A. Yu., et al. *Steam-gas turbine units: ejectors of condensing units: study guide for higher education institutions*. Moscow, 2018, 75 p. [in Russian]
- 20 Sokolov, Ye.Ya. *Jet devices*. Moscow, Energoatomizdat, 1989, 115 p. [in Russian]