

UDC 004.942

## DEVELOPMENT OF SWITCHING CIRCUIT POLARITIES OF ELECTROMAGNETS DC

Aikeyeva A.A.<sup>1</sup>, Makhanov K.M.<sup>1</sup>, Tanskozhanova A.R.<sup>1</sup>, Rogovaya K.S.<sup>1</sup>,  
Nuradinuly Zh.<sup>1</sup>, Mukhtarova P.A.<sup>2</sup>

<sup>1</sup>The Karaganda State University named after the academician E.A. Buketov, [aikeyeva@mail.ru](mailto:aikeyeva@mail.ru)

<sup>2</sup>The Asia Pacific University Innovation and Technology, Kuala Lumpur, Malaysia

*This work is directed to the development of the management system of electromagnetic lifting installation. To develop such control system is necessary to create automatic system of switching the poles. The experiment model of levitation system is developed for carrying out prior experiments. The Arduino UNO platform on the basis of the Atmega328 microcontroller is chosen. In paper the description of L293D driver is presented and the principle of driver operation which is a part of the circuit is considered.*

**Keywords:** electromagnetic lifting installation, microcontroller, KT805 series transistor, L293D circuit driver.

### Introduction

With the increase in the depth of mining and the productivity of lifting equipment, in conditions of unstable loads, the requirements for qualitative parameters of the elements of the lifting complex, their reliability and durability increase. The consolidation of mining enterprises, the transition to the development of seams at great depths, causes an increase in the load on mine hoisting installations, and the intensity of their work increases.

The stability of the operation of mines and mines is largely determined by the reliable operation of underground transport and lifting installations of vertical trunks, through which the delivery of minerals and rocks to the surface.

Previously, for the transportation of rock mass, magnetic levitation was not used anywhere in the world, and the creation of this facility entails the introduction of a new innovative technology for transporting both mining mass in the mining industry and in other industries for lifting and transporting goods (for example, in construction).

Now there are not enough generalized theoretical and experimental studies which could be used while calculation and projection of the electromagnetic lifting installation based on magnetic levitation. The substance of the offered technology is concluded in application for rise and motion of skip of electromagnetic field force (a magnetic levitation) for realizing ropeless rise.

### 12. Statement of the problem

Ensuring skip motion in the horizontal as well as vertical direction requires the ordered switching of poles of electromagnets in the directing devices. Ensuring trouble-free operation of electromagnetic lifting installation requires switching polarities of hundreds of electromagnets. It causes the necessity of automatic control system development.

During the motion skip is under the influence of forces various in their origin and character. The specified forces can be subdivided into electrodynamic and mechanical. The results of the experimental and theoretical studies for a range motion speeds inherent in installations with a magnetic suspender showed that the force of aerodynamic resistance of the air environment is the dominating making resultant force of the skip motion resistance. Forces operating on the skip from the air environment at the most common problem setting are defined by the main vector of

aerodynamic force and its main moment concerning the center of masses. The experiment model of levitation system is developed for carrying out prior experiments.

### 13. The method of calculation

The developed experimental model consists of one directing device and the cart moving on it. The circuit of the experiment model corresponds to figure 1.

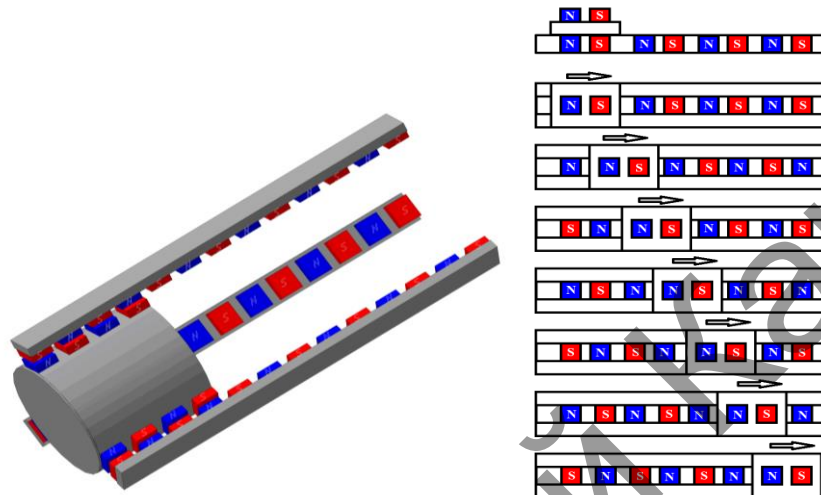

**Fig.1.** The circuit of the experiment model

The directing device consists of the directing conductor and electromagnets. The directing conductor electromagnets with alternation of the south and north poles are established on the whole length. In the directing conductor there are grooves for hinges. On the cart two electromagnets with alternation of poles and hinges are established.

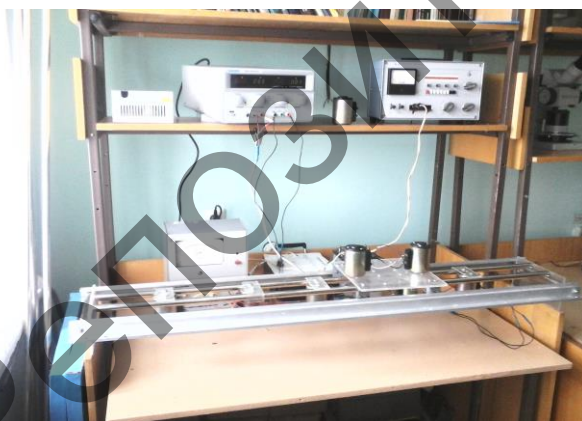
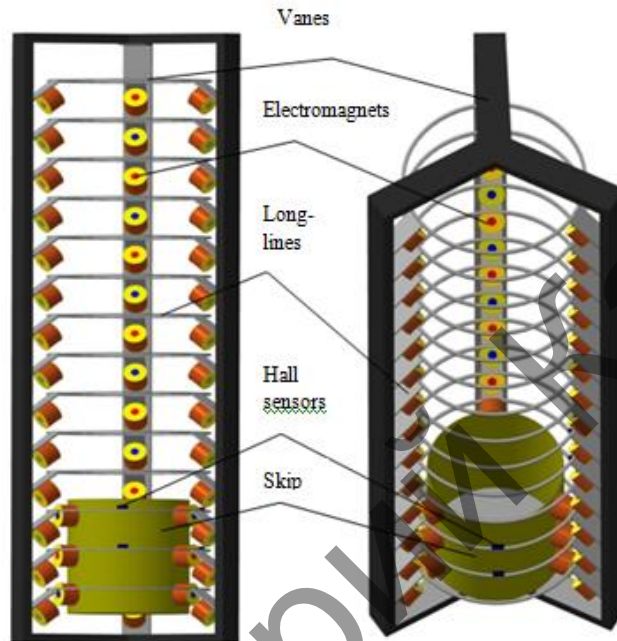

**Fig.2.** Experimental model of levitation system

Power supply voltage on electromagnets is given in the way that when unlike poles of electromagnets on the conductor and the cart are attracted, the similar poles of electromagnets make a start. Thanks to it the cart is set in motion. The motion speed of the cart is regulated by the electromagnetic force of electromagnets depending on power voltage.

Designed 3D model of experimental electromagnetic installation according to Figure 3. On the lower platform of the stand electromagnets with the alternating polarity are installed. Also, at the

bottom of the skip (cart) model two electromagnets with the alternating polarity are located. Electromagnets on the cart and on the platform are located in the way that when switching polarity of electromagnets on the platform the cart is set in motion. Also, the experiments with electromagnets of other types were made: with ferrite cores and steel cores. During the research some experimental stands of levitation system, consisting of one directing device and the cart moving on it and three directing devices located at 120 degrees relatively each other were developed.



**Fig.3.** 3D model of experimental electromagnetic installation

Inside on the skip the neodymium magnets located also at 120 degrees relatively each other with the alternating polarity are established. The directing device consists of the directing conductor and electromagnets. On all length of the directing conductor electromagnets with alternation of the south and north poles are established. The choice of parameters of electromagnets is carried out. Physical model of experimental electromagnetic installation shown on figure 4.

For the solution of the problem of automatic switching of polarity of the used electromagnets the circuit consisting of the relay, transistor key of the pulling together resistors was developed and constructed. As the operating part the Arduino Uno platform on the basis of Atmega 328 microcontroller was chosen. The choice is caused first of all by opportunities of this board, availability of buffer elements (for example L293D), simplicity and availability of the programming environment, etc. However, the main argument in favor of this choice is existence of the firmware translator, code compiler. The firmware programmer gets rid of the necessity

- manufacturing of the assembly board under the used microcontroller;
- purchase of programmer.

Therefore, it promotes economy of tools and time. Besides, procedure of installation and manufacture of a separate board of the microcontroller is interfaced to additional difficulties — "hand" distributing of the circuit, listing and at last, routine configuration of all necessary details.

The switching circuit of electromagnets polarities of the directing devices according to figure 5 was developed.

As performing element (switch) we used the one-channel module SRD-5VDC-SL-C relay as it allows to operate loading with high current or voltage easily. This circuit has both advantages and

shortcomings. The advantages refer to nearly 100% of relay contacting. Possibility of switching considerably high currents, etc. However, as it was already noted there are also shortcomings. And first of all, it is "bulkiness" and considerably high cost of the circuit due to use of a large number of relay. The attempt of use full-wave circuit consisting of four transistors was made. On each end of the coil we connected two transistors of various structure of p-n-p and n-p-n.



Fig.4. Physical model of experimental electromagnetic installation

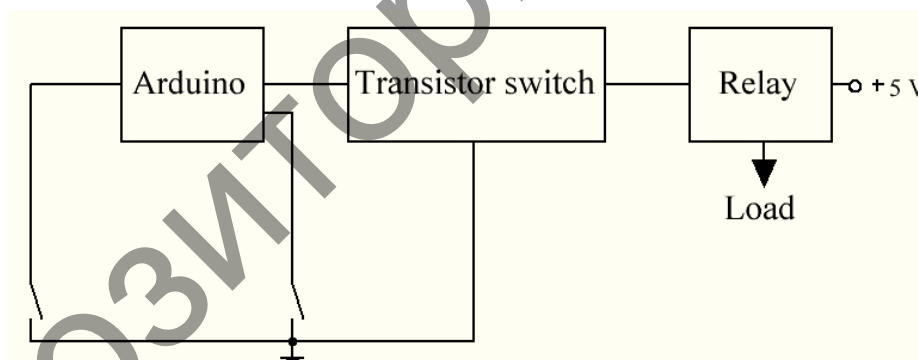

Fig.5. Prior switching circuit of electromagnets polarities

The idea was simple if to open two counter transistors with various base conduction at the same time, i.e. to exercise the control from the two pins of the controller, it is possible to change polarity of the coil by alternating the pairs of transistors. Duration and time of inclusion is defined programmatically. It was necessary to develop such a scheme in which the quantity of the used details would be minimum, and the operating ends of the microcontroller were enough for 10-12 electromagnetic coils.

Therefore it was expedient to include the circuit into the scheme which would allow to leave larger quantity of pins and to provide protection of voltage leaps and current at the time of switching electromagnets.

The review of literary data revealed the existence of chips, their scheme and logic of work allowed their use for realization of objective. One of such chips is L293D. The choice of the given series is caused by rather high parameters of the operating current. According to principal specifications of this series in peak situations, the commutation of currents to 1.6 amperes is

possible. This value quite satisfied our requirements. Besides, one chip with its number of ends and the order of their connection allowed commutation of two coils at the same time. One of advantages of this series chip L293D is existence of the firmware diodes. Diodes are switched on in reverse polarity that protects of the scheme

Thus, the scheme of connection similar to the scheme of connection of the three-phase engine according to figure 6 was taken as a basis of the scheme developed by us.

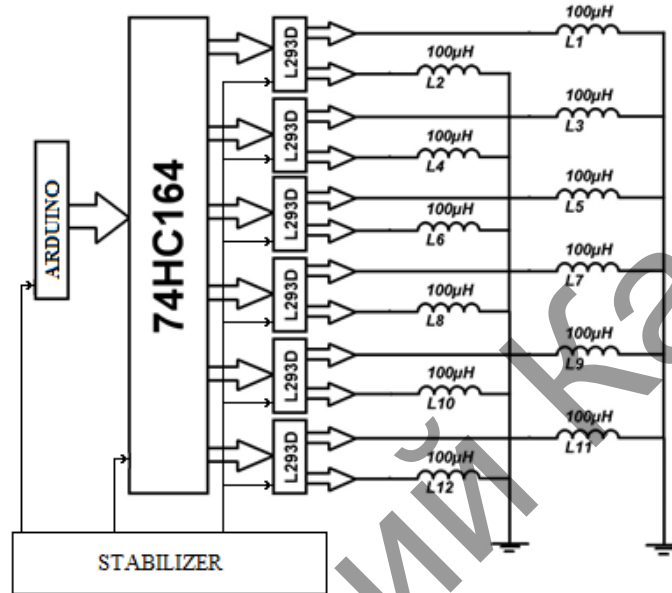

**Fig.6.** Connection diagram using 74HC164 register

Imitation of electromagnetic coils polarity switching was made. It is necessary to operate time of switching on and off precisely for achievement of maximum efficiency of operation according to figure 7. This scheme of polarity switching of electromagnets is applicable in the development of an experimental electromagnetic lifting device.

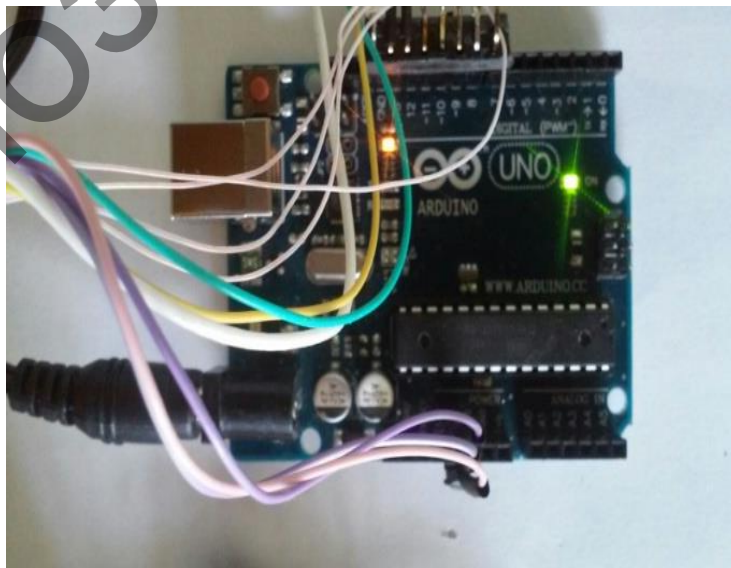

**Fig.7.** Device of operating electromagnets polarity switching

## Conclusion

Thus, on the basis of the automated systems analysis the imitating models of electromagnetic lifting installation construction considering design technology factors in a complex are developed.

In the course of the research, several experimental stands of the levitation system were developed, consisting of one guide device and a moving bogie and three guide devices located 120 degrees relative to each other. Inside, Neodymium magnets are installed on the skip, located also 120 degrees relative to each other with alternating polarity. The guide consists of a guide conductor and electromagnets. Electromagnets with alternating south and north poles are installed along the entire length of the guide conductor. Electromagnet parameters are selected.

For ensuring trouble-free operation of electromagnetic lifting installation switching circuits of electromagnets polarity in the directing devices with optimum number of the used details are found and developed. Operation on the basis of the Arduino UNO platform with the Atmega328 microcontroller, the firmware translator, the code compiler is realized. In operation of the scheme switching wide - pulse modulation of a signal is used. The scheme has the firmware protection against overheat and overloads.

## Acknowledgment

This article is written on the basis of results of the researches which are carried out within grant financing of the Ministry of Education and Science of the RK on the subpriority of "Technology of minerals", on the theme "Justification and Development of Energy Saving Technology of Rocky Mass Dredging by Means of Creation of Electromagnetic Lifting Installation", and also on the priority "Power and Mechanical Engineering" on the theme "Development of the System of Automatic Control and Complex Protection of Energy Saving Electromagnetic Lifting Installation".

## REFERENCES

- 1 Norenkova I.P. *Computer aided design*. Moscow, High School, 1986, 140 p. [in Russian]
- 2 Trudnoshin V.A., Pivovarova N.V. *Mathematical models of design objects*, 1988, 134 p.
- 3 Aleksandrovskii N.M., Egorov S.V., Kuzin R.E. *Adaptive systems of automatic control of complex technological processes*. Moscow, Energy, 1973, 272 p. [in Russian]
- 4 Zhautikov B.A., Aikeyeva A.A., Zhautikov F.B., Mukhtarova P.A. *Electromagnetic lifting installation (unit)*. Innovative patent № 27177 of Republic of Kazakhstan.
- 5 Zipkin Ya.Z. *Fundamentals of the theory of automatic systems*. Moscow, Nauka, 1977, 122p. [in Russian]
- 6 Kudryavtsev E.M. GPSS World. *Basics of simulation of different systems: scientific publication*. Moscow, DMK Press, 2004, 317 p.
- 7 Makarova I.M., Lokhina V.M. *Intelligent systems of automatic control*. Moscow, FIZMATLIT, 2001.- 356 p. [in Russian]
- 8 Ter - Akopov A.K. *Dynamics fast elektromagnitov*. Moscow, Energy, 1965, 167 p. [in Russian]
- 9 Slivinskaya A.G. *Electromagnets and permanent magnets*. Moscow, Energia, 1972, 248 p. [in Russian]