

## VARIATION OF SPATIALLY HETEROGENEOUS RADIATION BY COORDINATE-SENSITIVE RECEIVER

Karabekova D.Zh., Khassenov A.K, Kissabekova P.A., Satybaldin A.Zh.,  
Tungushbekova M.K.

E.A. Buketov Karaganda State University, Karaganda, Kazakhstan, [karabekova71@mail.ru](mailto:karabekova71@mail.ru)

*The developed device is intended to analyze the state of thermal insulation of underground pipelines. The proposed heat flow meter uses current heating of the sensor element in the process of temperature measurement. This will improve the accuracy of temperature measurement and maintain the reference temperature measured previously using current heating. The developed device has several identical plates, each of which can receive radiation. Formulas for determining energy parameters based on calibration of a coordinate-sensitive receiver by a spatially uniform heat flow generated by an electric current are obtained.*

**Keywords:** thermal methods of non-destructive testing, thermal energy, battery-operated thermoelectric sensor, heat flow meter, energy balance

### Introduction

Numerous studies show that the most complete technical diagnostics requirements of thermal networks and technological facilities are currently satisfied with non-destructive control methods, which are based on monitoring and automated registration of the temperature state of processes. Currently, the method of thermal non-destructive testing has become one of the most popular in heat engineering, construction and industrial production. The experience of foreign countries shows the effective use of heat flow meters of non-destructive control for the purposes of normative state of objects and building structures [1].

All known thermal methods of non-destructive testing are based on the use of thermal energy of a controlled object, which spreads throughout its surface area. The resulting temperature field becomes a source to inform the operator of the presence or absence of all kinds of defects both on the surface and in the depth of the material from which the controlled product is made by assessing the processes of heat transfer occurring inside the object. Among the numerous types of non-destructive testing, a special place is given to the thermal method of control. Since 65 – 95% of the existing forms of energy in electronic equipment eventually turn into thermal, which confirms the expediency of choice, which characterizes the parameters' qualities, technical states and the generated heat energy [2].

### 1. Problem statement

Thermal control is based on measuring, monitoring and analyzing the temperature of controlled objects. The main condition for the application of thermal control is the presence of thermal flows in the controlled object. The process of transmission of thermal energy, the release or absorption of heat in the object leads to the fact that its temperature changes relative to the environment. The distribution of temperature on the surface of the object is the main parameter in the thermal method, since it carries information about the peculiarities of the heat transfer process, the mode of operation of the object, its internal structure and the presence of hidden internal defects [3]. In the devices of the thermal method of control, the information about defects is carried by the temperature and thermal flow of the surface of the controlled object, the values of which are determined by the change in the thermal and geometric characteristics of the violations. In this regard, the development and creation of thermal flow devices for heat supply systems are of particular interest.

As the results of numerous studies of thermal insulation of underground thermal networks show, the most effective method of non-destructive testing is based on comparison of calculated and experimental values of temperature distribution on the surface of the ground over heat networks [4]. Thermal methods of non-destructive testing have been widely used for various types of protective coatings, for the analysis of the state of thermal insulation of underground pipelines, construction structures, etc. [5].

The extensive practice of testing underground heat networks has shown that methods based on monitoring of the temperature state of the heat conductors are most fully satisfied with all the requirements of their technical diagnostics. The most effective among them is the method of non-destructive control of the state of thermal insulation of the channel-free heat conductors, based on comparison of calculated and experimental values of the distribution of temperature on the surface of the ground (coating) over the heat networks.

A fault in the thermal insulation causes a change in the temperature on the protective coating surface. It is possible to conclude the state of thermal insulation on the basis of the data on the surface temperature of insulation and the temperature field inside the object under investigation. The temperature field of the insulation surface can be obtained using thermocouples or resistance thermometers by contact method. However, this method of temperature measurement results in significant errors due to the temperature field distortion in the contact area. The accuracy is significantly reduced by measuring the average value of the temperature fields on the entire surface of the thermal probe contact with the product. Thermal flow sensors can be used for this purpose.

Non-contact methods of measurement are the most promising for the study of these sources. Currently used for this purpose, the radiation receivers have a flat sensitive element with pronounced angular sensitivity dependence, and therefore giving sufficiently good results only when measuring the radiation of point sources. Applied spherical and hemispherical nozzles to a flat sensitive element allow only a small decrease in accuracy of measurements and increase their efficiency. At the same time, calibration methods are developed only for cases of radiation pulse duration much more or much less than the constant time of the device [6].

In order to solve these problems, we have developed several modifications of thermal flow sensors, whose readings are independent of changes in the state of the environment. A common element of these devices is a battery thermoelectric sensor of a special design, acting as a thermoelectric converter of thermal flow [7].

## 2. Experimental part

Developed thermal flow meter, works according to the auxiliary wall method. The thermometric module contains a thermal electric thermal flow converter, which is based on a battery thermoelectric sensor. The thermoelectric sensor is made in the form of a limited cylinder, one base of which represents the working surface, the second base has thermal contact with the body having an ambient temperature. Built-in heaters allow the thermal flow through the thermoelectric sensor in directions perpendicular to its bases. The heat flow generated by the heater is an instrument monitor with which the thermal flows of the objects under investigation are compared. Areas with possible insulation faults result in an increase in the signal output of the thermal flow meter [8, 9].

In the device, the heat flow flows through the protective film to the sensitive element, the hot junctions of the thermal battery have a thermal contact with the protective film, and the cold junctions with the heat stabilizer (figure 1). In this case, the role of a heat stabilizer is performed by a massive body that transmits further heat flow through the bottom of the housing to the radiator. To exclude heat transfer from the side surface, the sensing element is surrounded by a heat insulator, and the entire system is closed by a conical side surface [7]. When a defect occurs in the pipeline, the temperature changes sharply, and a temperature anomaly of a fairly regular shape occurs, which differs by several degrees from the average temperature of the earth's surface.

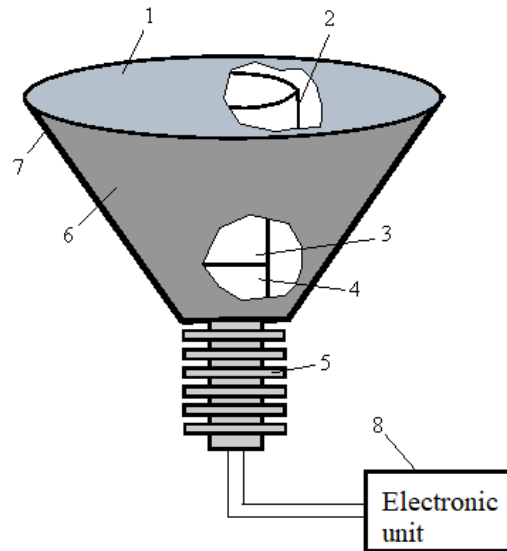

**Fig.1.** Schematic representation of the heat flow device:  
1-protective film; 2-calibration winding, 3-sensing element; 4-heat stabilizer; 5-radiator; 6-heat insulator; 7-side surface, 8-electronic unit

Abnormally high values of energy losses detected in this case indicate sections of the pipeline with completely or partially destroyed thermal insulation or mechanical damage to the pipeline material [8].

### 3. Results and discussions

Studies were conducted to calibrate the heat flow sensor. Using the standard calibration table of copper-constantan (table 1), from the thermoelectric moving force temperature increments are determined.

**Table 1.** The calibration table temperature sensor

№	$\Delta t, ^\circ C$	$\Delta \varepsilon, mV$	$A$	$\alpha_{av.}$
1	0	0	0	0.7824
2	5	4	0.8	
3	7	5.9	0.8428	
4	10	8.1	0.81	
5	15	12	0.8	
6	20	15.4	0.77	
7	25	19.2	0.768	
8	30	22.8	0.76	
9	35	26.2	0.7485	
10	40	29.7	0.7425	

A sensitive element is used as a thermoelectric battery converter. The sensitive element of such a receiver is a solid plate that serves as a heating element at the same time, or on it is a heating element. Let's divide the sensitive element into  $n$  equal square sections with side  $\Delta x$  and thickness  $d$  (fig. 2). The area of contact of this site with the neighboring one is  $\Delta x d$ , the area of the irradiated surface is  $\Delta x^2$ , the number of areas adjacent to the data is  $m$ . Maximum value  $m=4$ .

The energy balance equations for time  $t$  for any phase of the sensing element have the following form:

$$W_{st} + W_{rej} = W_u + W_T \tag{1}$$

where  $W_{st}=C \mathcal{G}_e$  – the amount of energy stored;  $C$  and  $\mathcal{G}_e$  - heat capacity and average excess temperature of the any section, respectively;  $W_{rej} = \alpha_e \Delta x^2 \int_0^t \mathcal{G}_e dt$  - the amount of rejected energy as a result of heat exchange with the environment;  $\alpha_e$  - heat transfer coefficient;  $W_u = \eta \Delta x^2 \omega_e$  - absorbed part of the radiation energy;  $W_e$  – the surface density of radiation energy;  $W_T = \lambda d \sum_{i=1}^m \int_0^t (\mathcal{G}_i - \mathcal{G}_e) dt$  - the amount of energy delivered to the site from the adjacent thermal conductivity;  $\lambda$  - thermal conductivity;  $\mathcal{G}_i$  - average excess temperature.

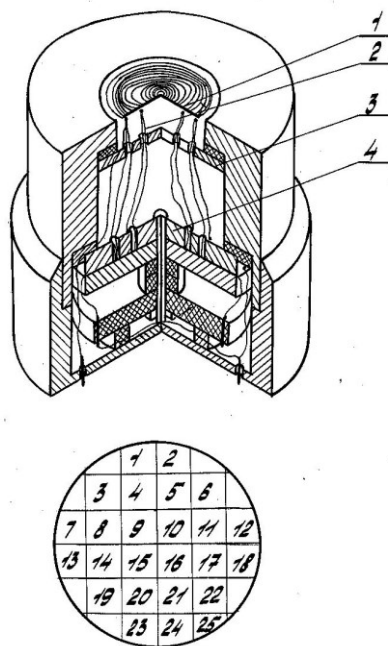

**Fig.2.** Schematic representation of the receiver and the separation of its sensing element into sections controlled by single thermocouples: 1- spiral; 2- single thermocouple instrument; 3- screen; 4- thermostatic element.

By substituting the value of  $W_{st}$ ,  $W_{rej}$ ,  $W_u$ , and  $W_T$  in the expression and taking into account the relationship between the mean excess site temperature and the response of the controlling temperature, we obtain a formula for determining the surface density of radiation energy in the any site during the time  $t$ :

$$\omega_e = \frac{1}{\eta} \left\{ A_{1e} [(1 - A_{2em})] \int_0^t U_e dt - A_{2e} \int_0^t U_e dt - A_{2e} \sum_{i=1}^m \int_0^t U_i dt \right\} \tag{2}$$

where  $U_e$  and  $U_i$  - reactions of thermocouples that control the regions;  $A_{1l}$ ,  $A_{2l}$  and  $A_{3l}$ , coefficients, that equal to:

$$A_{1l} = \frac{\alpha l}{k}; A_{2l} = \frac{\lambda d}{\alpha \Delta x^2}; A_{3l} = \frac{C}{k \Delta x^2} \tag{3}$$

$k$  - Seebeck coefficient of the thermo element.

The coefficients  $A_{11}$ ,  $A_{21}$  and  $A_{31}$  can be determined experimentally. To determine  $A_{11}$  and  $A_{21}$ , let's look at the stationary heating of the sensing element. The energy balance equation for time  $t$  for the first section will take the form:

$$W_{rej} = W_u + W_T, \quad (4)$$

$$\text{where } W_{rej} = \alpha_e \Delta x^2 \mathcal{G}_e t; W_u = \eta \Delta x^2 E_1 t; W_T = \lambda t d \sum_{i=1}^m (\mathcal{G}_i - \mathcal{G}_e), \quad (5)$$

$E_1$ - irradiation of the first section.

Substituting the values for  $W_{rej}$ ,  $W_u$  and  $W_T$  in the expressions and moving from excessive temperatures, we get a formula for determining the irradiation of the any site:

$$E_i = \frac{A_{1l}}{\eta} \left[ U_e - A_{2l} \sum_{i=1}^m (U_i - U_e) \right] \quad (6)$$

If the any section is not irradiated when the sensitive element is irradiated, i.e.  $E_1=0$ , then we get expressions for the experimental determination of the coefficient  $A_{21}$ :

$$A_{2l} = \frac{U_e}{\sum_{i=1}^m (U_i - U_e)} \quad (7)$$

To determine the coefficient  $A_{11}$ :

$$A_{1l} = \frac{A_q}{U_e - A_{2l} \sum_{i=1}^m (U_i - U_e)} \quad (8)$$

Given the conditions, we obtain a formula for determining the  $A_{31}$  coefficient:

$$A_{3l} = U_l^{-1} \left\{ A_{qt} - A_{1l} \left[ (1 - A_{2l} m) \int_0^t U_i dt - A_{1l} \sum_{i=1}^m U_i dt \right] \right\} \quad (9)$$

Thus, the determination of the surface energy density of radiation at the first site can be carried out using a formula (2), where  $A_{11}$ ,  $A_{21}$  and  $A_{31}$  are coefficients determined experimentally using formulas (7) – (9). The determination of site irradiation from stationary heating can be done by formula (6). The coefficients  $A_{11}$ ,  $A_{21}$  and  $A_{31}$  are individual characteristics of the every plot, since practically  $\Delta x$ ,  $d$ ,  $\lambda$  and  $k$  – change from plot to plot. In addition,  $A_{11}$  and  $A_{21}$  depend on the local heat transfer coefficient. We have experimentally determined the coefficients  $A_{11}$ ,  $A_{21}$  and  $A_{31}$  at a heat flux density of  $1534 \text{ W/m}^2$ . The dispersion of these coefficients, except for the above reasons, is influenced by the inhomogeneity of the spiral along the irradiated surface, since the spiral consists of turns of metal wire and dielectric gaps between them.

## Conclusions

The heat flow meter operates in the range from  $50$  to  $1500 \text{ W/m}^2$ , which corresponds to the normative heat losses, which are  $\sim 300 \text{ W/m}^2$ . The measurement time with secondary equipment is  $\sim 1$  min. The measurement error is 3% of the measured value. The conducted measurements confirm the principal possibility of using the proposed device for implementing the thermal method of non-destructive testing. Formulas are obtained for determining the energy parameters of such radiation, which are based on the calibration of a coordinate-sensitive receiver by a spatially uniform heat flow generated by an electric current.

## REFERENCES

- 1 Varganov I.S., Lebedev G.T., Konpov V.V. Current state and main problems of thermal non-destructive testing methods. *Prom. teplotekhnika*, 1983, Vol. 6, №2, pp. 80-93. [in Russian]
- 2 Gerashchenko O.A. *Fundamentals of heat metering system*. Kiev. 1984, 1971p. [in Russian]

- 3 Gerashchenko O.A., Gerashchenko T.G. Thermometric indicator for diagnostics of the heating system TIDHS-01. Kiev: Chas, 1991, p. 19. [in Russian]
- 4 Nesteruk D.A., Vavilov V.P. *Teplovoj kontrol' i diagnostika. (Thermal monitoring and diagnostics)*. Tomsk: TPU, 2007, 104 p. [in Russian]
- 5 Cherepanov V.Ya. *Izmereniya parametrov teploobmena. (Measurement of heat exchange parameters)*. Mir izmerenii, 2005, № 9, pp. 415. [in Russian]
- 6 Kuritnik I.P., Nussupbekov B.R., Karabekova D.Zh. Device for monitoring underground heating lines. *Bulletin of Karaganda University. Physics Series*, 2014, No. 4(76), pp. 58 – 62. [in Russian]
- 7 Nussupbekov B.R., Karabekova D.Zh., Khassenov A.K., et al. *Heat flow meter*. Kazakhstan Republic Patent № 1588, 2016, Bulletin 4, 4 p. [in Russian]
- 8 Nussupbekov B.R., Karabekova D.Zh., Khassenov A.K. Thermal Methods and Non-Destructive Testing Instrumentation. *Measurement Techniques*, 2016, Vol. 59, № 6, pp. 644 – 648.
- 9 Nussupbekov B.R., Karabekova D.Zh., Khassenov A.K. Heat flow meter for the diagnostics of pipelines. *Proceedings of the Int. Conf. SPIE Photonics Applications in Astronomy, Communications, Industry, and High-Energy Physics Experiments*. Wilga, Poland, 2016, pp. 348 – 354.

Article accepted for publication 25.05.2020

РЕПОЗИТОРИЙ КАРГУ