

R.E. Sakenova¹, N.K. Erdybaeva¹, A.D. Pogrebnyak², M.K. Kylyshkanov³

¹*D. Serikbayev East Kazakhstan State Technical University, Ust-Kamenogorsk, Kazakhstan;*

²*Center for Priority Development «VERITAS», D. Serikbayev East Kazakhstan State Technical University, Ust-Kamenogorsk, Kazakhstan; Sumy State University, Ukraine;*

³*«Ulba Metallurgical Plant» JSC, Kazakhstan
(E-mail: Sakenova_rimma@mail.ru)*

The study of multilayer coatings based on MoN(MoZr)ZrN and (TiMo)N/(TiMo), (CrZr)N/(CrZr) obtained by the method of vacuum-arc deposition

In the article the results of experimental studies of multilayer coatings MoN(MoZr)ZrN and (TiMo)N/(TiMo), (CrZr)N/(CrZr), obtained on A570 Grade stainless steel samples with a Ra roughness of up to 0.09 μm are presented. Coatings were formed by vacuum-arc evaporation of cathodes in the installation Bulat-6. After deposition of multilayer coatings by scanning electron microscopy and microanalysis, a non-uniform distribution of zirconium, chromium, nitrogen and molybdenum was found on the surface of the samples. The research results show that good tribological properties in combination with improved physico-mechanical properties make the deposited material promising for use as a protective material for machines and tools operating in extremely difficult working conditions.

Keywords: multilayer coatings, cathode arc, microstructure, two-phase state, vacuum-arc method, microhardness, wear resistance.

1. Introduction

During the operation of machine parts, mechanisms and metal working machinery, their surface layer is subjected to mechanical, thermal and chemical influences. Thus, a significant decrease in performance in most cases occurs as a result of wear, erosion and corrosion of the surface. A significant resource for increasing the efficiency of machine parts and mechanisms is to improve the physico-mechanical properties of materials and increase their tribological properties [1–2].

The analysis of scientific publications suggests that the use of vacuum-arc magnetron installations, where highly ionized source atoms and excited target atoms allow to create microcrystalline and nanolayer coatings on the surfaces of various products, and thereby improve the operational properties of materials [3].

It has already been proved that the multilayer coatings demonstrate better properties, including magnetic and electrical, in comparison with the single-layer ones. The substitutional defects may occur along the interfaces between adjacent layers in multilayer films, when some of the elements of one layer enter the crystal lattice of the adjacent one, thus replacing its atoms. This process usually leads to generation of strain energy proportional to the shear modulus of the material. The layers with different shear modulus prevent the movement of dislocations, thus preventing the destruction of the coatings material. Firstly such type of model to describe hardness enhancement was proposed by J.S. Koehler and then approved and followed by many experimental and theoretical works, as well as by review articles. Additionally, deviations or redistribution of dislocations and cracks at the grain boundaries help to increase the coatings resistance to stress, wear and destruction. The multilayer structure significantly reduces the influence of interlayer cracking and allows it's employing under large dynamic loads. The alternation of nanoscale layers with dissimilar physical-mechanical characteristics allows to change significantly the properties of multilayer coatings, such as concentration of internal stresses, crack propagation and, hence, to increase the fracture toughness of such materials [4–6].

In work (patent RU No. 2423547, C23C 14/24, 2011) a method for obtaining a coating for the cutting tool, including vacuum ion-plasma application of a wear-resistant coating based on a complex titanium-chromium-zirconium nitride, additionally alloyed with aluminum and niobium by means of three arc evaporators arranged horizontally in one plane, connected to the drip phase separator, the following compositions of titanium-aluminum cathode made of W-5 alloy, combined zirconium-niobium cathode and chromium cathode. The disadvantage of this technology is that the coating has insufficient hardness and viscosity, as a result, the coating is more subject to wear, especially in conditions of alternating loads, as well

as at high cutting speeds, it quickly appears microcracks on the pads, which leads to its chipping and destruction during cutting.

The purpose of this work is to study the multilayer coatings MoN(MoZr)ZrN and (TiMo)N/(TiMo), (CrZr)N/(CrZr) obtained by the method of vacuum-arc deposition, as well as to study the effect of the technological settings of deposition on the formation of the microstructure of subsurface layers samples.

2. Materials and methods of the experiment

In this work, we investigated the multilayer coatings MoN(MoZr)ZrN and (TiMo)N/(TiMo), (CrZr)N/(CrZr) obtained in a vacuum arc chamber. Molybdenum and zirconium were used as cathodes. Multilayer coatings are obtained by vacuum-arc sequential evaporation of the cathodes Mo, Zr, Ti, Cr in the installation of Bulat-6 with two evaporators. Polished substrates of A 570 Grade 36 stainless steel with surface roughness Ra up to 0.09 μm were used for the deposition. The multilayer coatings were deposited by vacuum-arc evaporation of cathodes in a vacuum-arc device Bulat-6 with two evaporators, which allows deposition of nanostructured multilayer coatings. Figure 1 shows a principal scheme of the deposition system. The vacuum chamber (1) (base pressure in the chamber was 0.001 Pa) was equipped with a system of automatic nitrogen pressure control (2) and two evaporators consisting of appropriate metals for each coating (purity of metallic target was 99.8 %). The substrate holder (5) was mounted on a rotating stainless steel plate (300×300 mm) on which the substrates (6) were placed. BULAT-6 was also equipped with DC voltage source (7), the value of which can be varied between 5 and 1000 V, and high-voltage impulse generator (8) with adjustable voltage pulse amplitude of 0.5–2 kV and repetition frequency of 5–7 kHz [7–9].

The substrate cleaning process was carried out prior to coatings deposition, while applying a 1 kV substrate potential. Further, nitrogen was injected into the chamber to fabricate nitrides of appropriate refractory or transition metals.

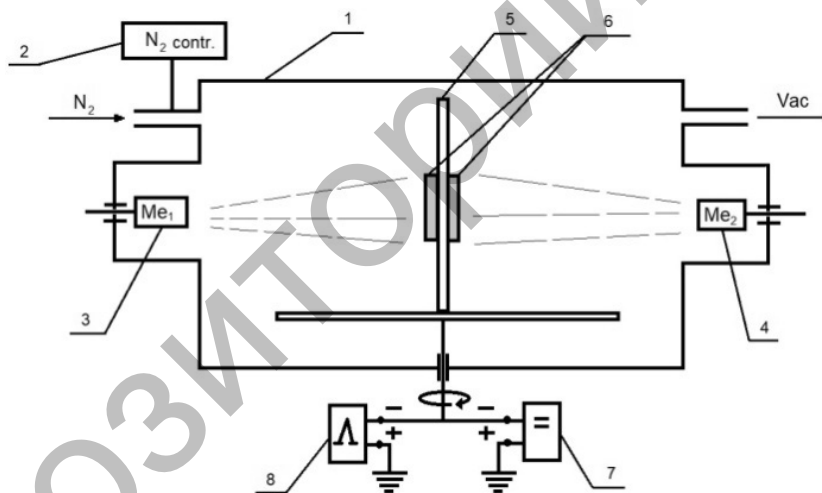

Figure 1. A principal scheme of the Bulat-6 deposition system

Rotation of the substrate holder allowed deposition of alternating layers, while injection and stopping the injection of nitrogen into the deposition chamber allowed deposition of nitride and pure metallic layers.

The structural phase state of the deposited coatings was investigated by X-ray diffraction analysis on a XPert-PRO diffract meter in Cu-K α radiation. The elemental composition of the surface and cross section of the coatings was investigated using scanning electron microscopy with the INCA microanalysis system (REM). The structure-phase state of the deposited coatings was analyzed using X-Ray diffraction (XRD) in terms of θ -2 θ scans in Bragg-Bertrano geometry. Scanning electron microscopy with Energy-dispersive spectra (SEM with EDX) was used for studies of coatings surface and elemental composition, as well as coatings cross-sections. In addition, laser digital scanning was used to study surface roughness of the coatings. Time of flight secondary ion mass-spectrometry (ToF SIMS) was used for studies of distribution of elements along the depth. Hardness of the deposited coatings was studied by micro-Vickers method. At least 10 indentations were made for each sample and for each loading [10–12].

Experimental studies were carried out in the research laboratories of Sumy State University (Ukraine), the National Research Laboratory of collective use of the East Kazakhstan State University named after

S. Amanzholov, Regional university engineering laboratory «IRGETAS» of the East Kazakhstan Technical State University named after D. Serikbayev.

3. Results and discussion

Vacuum-arc evaporation of Mo and Zr cathodes resulted in a coating with a dense structure, without obvious defects and of equal thickness (8 μm) over the entire surface of sample No. 894. Figure 2b presents the results of x-ray analysis.

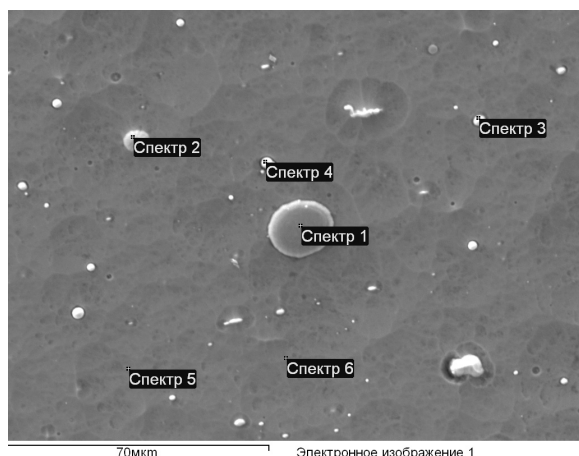

Figure 2a. RAM image

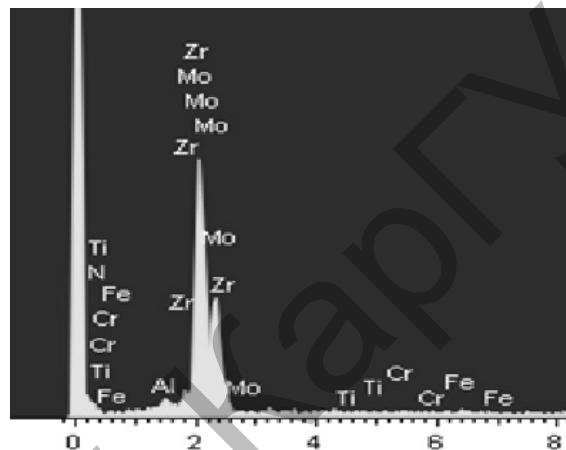

Figure 2b. EDS spectra of the sample surface with MoN(MoZr)ZrN coating

The data of scanning electron microscopy, shown in Figure 2 and Table 1 shows that the chemical composition of the coatings in the layers under study is different.

From the picture of the raster image of the multilayer coating, the selection of particles of micrometer scale is seen. Spectrum analysis shows a different quantitative distribution of elements in each layer.

Interpretation of the spectra of the layer-by-layer coating is presented in Table 1.

Table 1

The elemental composition of the coating MoN(MoZr)ZrN

Spectrum	N	Al	Ti	Cr	Fe	Zr	Mo	Sum
Spectrum 1	12.64	0.53	0.00	0.43	1.00	50.52	34.87	100.00
Spectrum 2	12.39	0.34	0.00	0.00	0.65	54.96	31.67	100.00
Spectrum 3	12.89	0.68	0.00	0.00	0.79	59.49	26.16	100.00
Spectrum 4	11.78	0.38	0.00	0.60	1.06	58.86	27.32	100.00
Spectrum 5	0.00	0.60	0.00	0.00	1.04	58.59	39.76	100.00
Spectrum 6	10.04	0.89	0.00	0.00	1.54	51.80	35.73	100.00
The average	9.96	0.57	0.00	0.17	1.01	55.70	32.58	100.00
Standard deviation	4.98	0.20	0.00	0.27	0.30	3.88	5.22	
Max.	12.89	0.89	0.00	0.60	1.54	59.49	39.76	
Min.	0.00	0.34	0.00	0.00	0.65	50.52	26.16	

In all layers there is (spectra 1–6 in Table 1) the maximum content of molybdenum, zirconium and nitrogen. The appearance of nitrogen is due to the residual gas content in the cell of the Bulat-6 unit. The data of energy dispersive analysis (Fig. 1) shows the presence of Mo and Zr in A 570 Grade steel.

Along with clear lines of phases with maximum intensity, the appearance of broadened peaks of lesser intensity is observed, which, apparently, indicate a decrease in the grain size and the formation of nanocrystallites in the coating structure. Figure 3 shows the X-ray diffraction analysis of the coating.

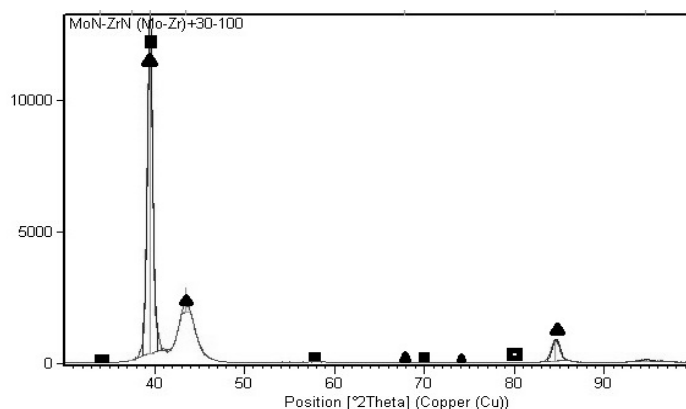

Figure 3. XRD spectors of MoN(MoZr)ZrN coatings (series 3)

Table 2

The phase composition of the multilayer coating

No.	2θ	d_{hkl} , Å	ZrN, d_{hkl} , Å	Mo ₂ N, d_{hkl} , Å
1	33.8	2.625	111	-
2	39.2	2.298	200	111
3	43.5	2.085	-	200
4	57	1.614	220	-
5	68	1.379	311	220
6	74	1.281	-	311
7	79	1.212	400	-
8	84.8	1.143	-	400

From metallographic images of the surface of the coating, you can see that the structure contains dispersed particles of predominantly spherical shape. Using the method of the ratio of the areas occupied by particles, the volume fraction of these particles was calculated, which was $\langle f \rangle = 3\%$. The period of the unit cell phase is $a = 4.56$ Å. X-ray diffraction analysis data (Table 2) show the appearance of zirconium and molybdenum nitride phases. The most intense peak corresponds to two phases: (200) ZrN and (111) Mo₂N.

Figure 4a presents an image of the cross section of the sample in a scanning electron microscope. Data interpretation of the spectrum of the SEM image are presented in Table 3. Spectra 4 and 5 correspond to the chemical composition of the original sample substrate steel A 570 Grade.

Spectra 1, 2 and 3, taken from a layer with a thickness of 8 μm, show the presence of Mo and Zr. According to the energy dispersive and X-ray structural analyzes, these phases are identified as ZrN, Mo₂N.

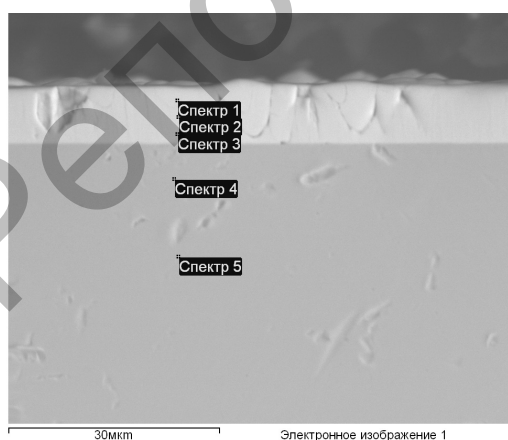

Figure 4a. SEM-image of the cross-section of the sample with a MoN(MoZr)ZrN coating

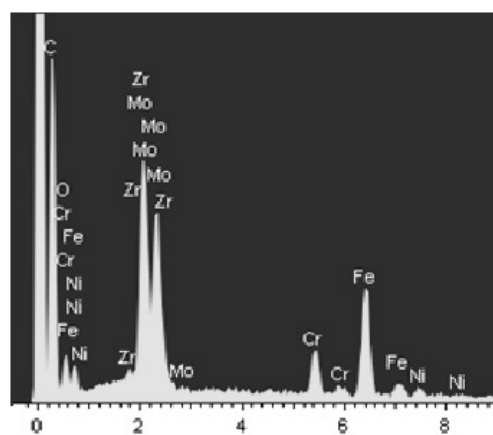

Figure 4b. Energy Dispersive Spectrum of a Section Sample Cross Section

Elemental composition of the coating and the substrate

Spectrum	O	P	S	Cr	Mn	Fe	Ni	Zr	Mo	Sum
Spectrum 1	12.98			6.78		21.83	2.53	27.99	27.89	100.00
Spectrum 2	16.46			6.93		22.82	2.18	26.82	24.78	100.00
Spectrum 3	15.28			7.85		25.29	2.53	25.83	23.23	100.00
Spectrum 4	6.18	0.42	0.46	17.30	1.53	65.94	8.16			100.00
Spectrum 5	5.45	0.38	0.37	17.27	1.94	66.68	7.91			100.00
Max.	16.46	0.42	0.46	17.30	1.94	66.68	8.16	27.99	27.89	
Min.	5.45	0.38	0.37	6.78	1.53	21.83	2.18	25.83	23.23	

The microhardness of the applied coatings was determined with a PMT-3 microhardness tester, with the Vickers method. For each sample and for each load, at least 20 holes were made. After spraying, the microhardness increased. Studies of the surface morphology of the deposited samples No. 877 and No. 891 were carried out using a Keyence VK-X100 digital microscope.

The image of the surface of sample 877 is shown in Figure 5, where it can be seen that a fairly smooth surface with droplet fractions was formed, which is characteristic of coatings applied by the vacuum-arc method. The average roughness of the samples did not exceed 0.3 microns.

In the coatings, a two-phase state is formed (nitride and metal phases), and each phase corresponds to a specific layer. In the spectrum of sample No. 877, an overlap of peaks from Ti and Mo is observed. Also the expansion of the peaks from the plane (222) is seen, indicating a high disorder of polycrystallites, probably from the molybdenum phase.

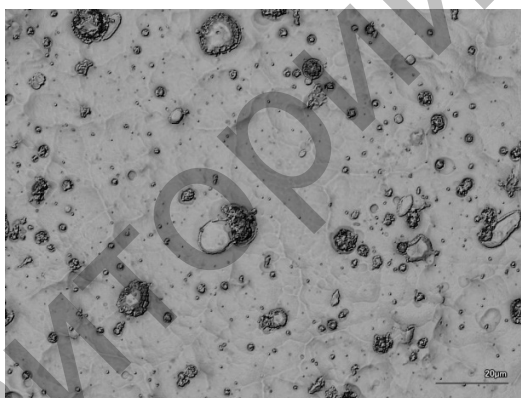

Figure 5. Surface morphology of sample 877

Typical X-ray spectra of the studied coatings are presented in Figure 6. The spectrum for each sample has a corresponding color. As can be seen from Figure 6, the most intense peaks correspond to the (111) and (200) planes, but we can also observe weaker reflections from the (311) and (220) planes.

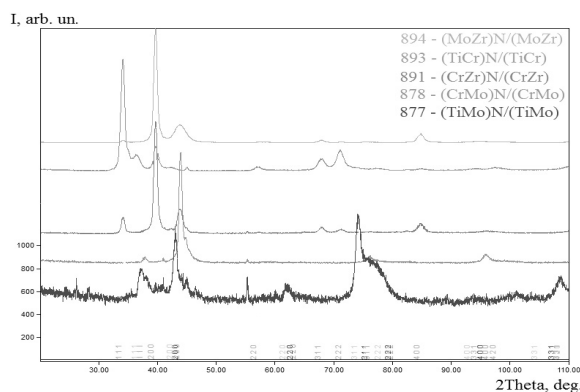
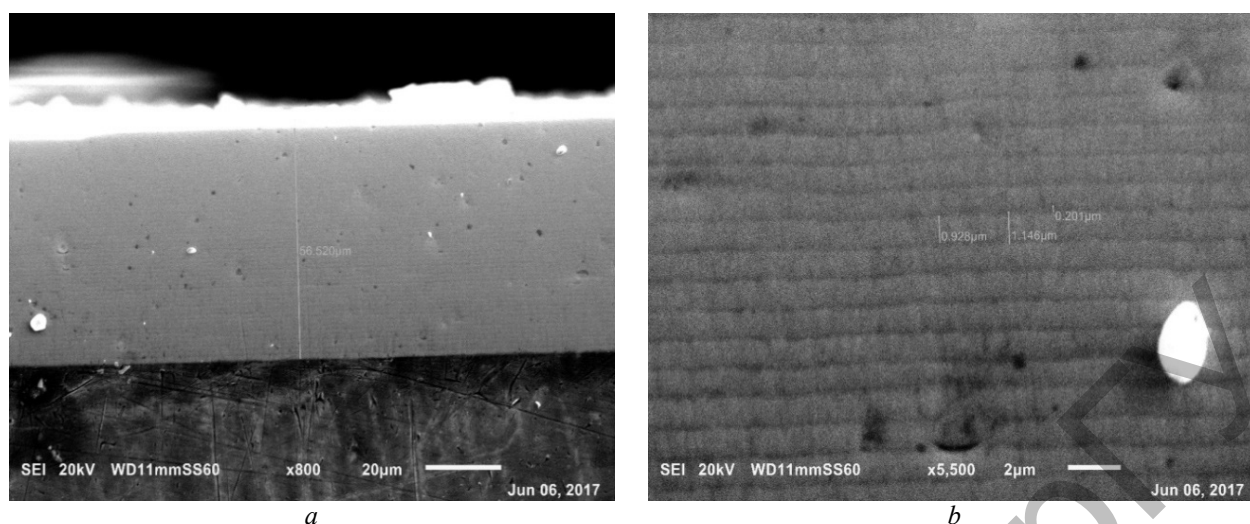

Figure 6. XRD specters of samples



a — general view; *b* — layers with a higher magnification $\times 5500$

Figure 7. SEM images of the cross section of sample 891

The cross-sectional view at magnifications of $\times 800$ (general view) and $\times 5500$ (enlarged nitride and metal layers) of sample No. 891 is shown in figures 7*a* and 7*b*, respectively. We can observe a good flatness of the layers: they do not intersect and have clear visible boundaries. The total thickness of the coating is about 54 microns, and the individual layers are about 750 nm thick (nitride layers) and 150 nm (metallic layers). The data obtained are in good agreement with the deposition parameters for nitride and pure metal layers.

The hardness of the coatings for samples № 891 and № 877 in the precipitated state was studied by the Vickers method using a TimShimadzu HMV-G Micro Vickers microhardness tester. The average hardness of the HV0.1 coatings was 2700, while the HV0.5 and HV1 coatings were 2250 and 1700, respectively, which makes them as complex as the protective coatings.

Conclusion

Vacuum-arc evaporation of Mo and Zr cathodes was obtained by coating with a dense structure, without obvious defects and of equal thickness over the entire surface of the sample. The microstructure of the coatings is represented by the cubic phases MoN and ZrN with the preferential orientation of (200) and (111), (220), respectively. The deposition of a multilayer coating on A570 Grade MoN/ZrN steel resulted in the appearance of ZrN and Mo₂N phases in the surface layers. This is evidenced by data of X-ray analysis. It was established that the particles of the nitride phase are predominantly spherical in shape with a volume fraction of 3 % and sizes of 1–3 μm and larger particles with a diameter of about 12 μm .

To determine the characteristics of the coatings, various methods of analysis were used, such as XRD, EDS, REM methods, and also hardness tests were carried out. For sample No. 877, the shape and intensity of the diffraction peaks from the nitride layers may indicate a fairly good crystal structure of the nitride layers. In accordance with the research results, the upper layers of the coatings are metals, the ratio between the metal components is in the range of 0.9–0.92.

In sample No. 891, there is a good flatness of the layers, they do not intersect and have clear visible boundaries. The total thickness of the coating is about 54 microns, and the individual layers are about 750 nm thick (nitride layers) and 150 nm (metallic layers).

Two-phase state (nitride and metallic phases) was formed in the coatings, and each phase corresponds to certain layer. For sample No. 877 we can observe overlapping of peaks from Ti and Mo (sample 877). Broadening of the peaks from (222) plane is also observed indicating at high disorder of polycrystallites, probably from molybdenum phase. Shape and intensity of diffraction peaks from nitride layers can point on pretty good crystalline structure of the nitride layers. In according to the results of the EDS studies, top layers of the coatings are metallic ones, the ratio between metallic components is in the range 0.9–0.92.

Cross-sectional view under magnification at $\times 800$ (total view) and $\times 5500$ (magnified nitride and pure metallic layers) of the sample No. 891 are presented in Figure 7*a* and 7*b* accordingly. We can observe good

planarity of layers; they do not intersect and have clear visible borders. Total thickness of the coating is around 54 μm , while alternative layers have the thickness around 750 nm (nitride layers) and 150 nm (for pure metallic layers). The obtained data is in a good agreement with the deposition parameters, where one can see 5 minutes and 1 minute deposition times for nitride and pure metallic layers.

For samples No. 877 and No. 891, the hardness of the coatings in the deposited state was studied by the Vickers method using a Tim. Shimadzu HMV-G Micro Vickers microhardness tester. The average hardness of the HV0.1 coatings was 2700, while the HV0.5 and HV1 coatings were 2250 and 1700, respectively, which makes them as complex as the protective coatings.

Hardness tests showed a maximum hardness of coatings close to 24 GPa, due to the Hall-Petch amplification effect, which is much higher than single-layer coatings. The data on microhardness measurements indicate the hardening of the surface layer by 4.3 %.

This work was carried out with the financial support of PTsF by the Science Committee of the Ministry of Education and Science of the Republic of Kazakhstan on the topic «Development of production technology for medical products from tantalum and niobium».

References

- 1 Pogrebnjak, A.D., Bagdasaryan, A.A., Yakushchenko, I.V., & Beresnev, V.M. (2014). The structure and properties of high-entropy alloys and nitride coatings based on them. *Russian Chemical Reviews*, 83, 11, 1027–1061.
- 2 Pogrebnjak, A.D., Shpak, A.P., Azarenkov, N.A., & Beresnev, V.M. (2009). Structures and properties of hard and superhard nanocomposite coatings. *Physics-Uspekhi*, 52, 1, 29–54.
- 3 Pogrebnjak, A.D., Bagdasaryan, A.A., Pshyk, A., & Dyadyura, K. (2017). Adaptive multicomponent nanocomposite coatings in surface engineering. *Physics-Uspekhi*, 60, 6, 586–607.
- 4 Pogrebnjak, A.D., et al. (2018). Experimental and theoretical studies of the physicochemical and mechanical properties of multi-layered TiN/SiC films: Temperature effects on the nanocomposite structure. *Composites. Part B: Engineering*, 142, 1, 85–94.
- 5 Bobzin, K., Brögelmann, T., Kruppe, N.C., Arghavani, M., Mayer, J., & Weirich, T.E. (2017). Plastic deformation behavior of nanostructured CrN/AlN multilayer coatings deposited by hybrid dcMS/HPPMS. *Surface and Coatings Technology*, 332, 253–261.
- 6 Pogrebnjak, A.D., Sobal, O.V., Bersenev, V.M., Turbin, P.V., Kirik, G.V., & Makhmudov, N.A., et al. (2010). Phase composition, thermal stability, physical and mechanical properties of superhard on base Zr-Ti-Si-N nanocomposite coatings. Proceedings from Nanostructured Materials and Nanotechnology IV, 34th International Conference on Advanced Ceramics and Composites, ICACC; Daytona Beach, FL; United States. January, 31, 7, 127–138.
- 7 Kasiuk, J.V. et al. (2014). Correlation between local Fe states and magnetoresistivity in granular films containing FeCoZr nanoparticles embedded into oxygen-free dielectric matrix. *J. Alloys Compd.*, 586, 1, 432–435.
- 8 Bondar, O.V., Pogrebnjak, A.D., Takeda, Y., Postolnyi, B., Zukowski, P., & Sakenova, R., et al. (2019). Structure and properties of combined multilayer coatings based on alternative triple nitride and binary metallic layers. *Lecture Notes in Mechanical Engineering*, 31–40.
- 9 Caicedo, J.C., Amaya, C., Yate, L., Nos, O., Gomez, M.E., & Prieto, P. (2010). Hard coating performance enhancement by using [Ti/TiN]_n, [Zr/ZrN]_n and [TiN/ZrN]_n multilayer system. *Materials Science and Engineering. B*, 171, 56–61.
- 10 Koshy, R.A., Graham, M.E., Marks, L.D. (2010). Temperature activated self-lubrication in Cr/Mo₂N nanolayer coatings. *Materials Science and Engineering*, 204, 9–10, 1359–1365.
- 11 Yao, S.H., & Su, Y.L. (1997). The tribological potential of CrN and Cr(C, N) deposited by multi-arc PVD process. *Wear*, 212, 1, 85–94.
- 12 Wang, Q., Zhou, F., & Yan, J. (2016). Evaluating mechanical properties and crack resistance of CrN, CrTiN, CrAlN and CrTiAlN coatings by nanoindentation and scratch tests. *Surface and Coatings Technology*, 285, 203–213.

Р.Е. Сакенова, Н.К. Ердыбаева, А.Д. Погребняк, М.К. Кылышканов

Вакуумды-доғалық әдіспен алынған MoN(MoZr)ZrN және (TiMo)N/(TiMo), (CrZr)N/(CrZr) негізіндегі көпқабатты жабынды зерттеу

Мақалада 0,09 мкм дейінгі Ra кедірі бар A570 маркалы тот баспайтын болаттың бетіне жабылған көпқабатты жабындылар MoN(MoZr)ZrN және (TiMo)N/(TiMo), (CrZr)N/(CrZr) жабуда алынған эксперименттік зерттеулердің нәтижелері келтірілген. «Булат-6» қондырғысында катодты вакуумды-доғалық булану әдісімен жабындар алынды. Көпқабатты жабындарды сканерлейтін электронды микроскопия және микроталдау әдісімен түсіргеннен кейін цирконийдің, хромның, азоттың және молибденнің үлгілердің бетіне біркелкі таралуы анықталды. Зерттеу нәтижелері жақсы трибологиялық қасиеттері жақсартылған физика-механикалық қасиеттермен үйлескенде балқытылған

материалды жұмыстың өте ауыр жағдайларында жұмыс істейтін машиналар мен құрал-саймандар үшін қорғау материалы ретінде қолдану үшін өте тиімді.

Кілт сөздер: көпқабатты жабындылар, катодтық доғалар, микроқұрылым, екіфазалы күй, вакуумды доғалы әдіс, микроқаттылық, тозуға төзімділік.

Р.Е. Сакенова, Н.К. Ердыбаева, А.Д. Погребняк, М.К. Кылышканов

Исследование многослойных покрытий на основе MoN(MoZr)ZrN и (TiMo)N/(TiMo), (CrZr)N/(CrZr), полученных методом вакуумного-дугового осаждения

В статье представлены результаты экспериментальных исследований многослойных покрытий MoN(MoZr)ZrN и (TiMo)N/(TiMo), (CrZr)N/(CrZr), полученных на образцах из нержавеющей стали A570 Grade с шероховатостью Ra до 0,09 мкм. Покрытия были сформированы методом вакуумно-дугового испарения катодов в установке «Булат-6». После нанесения многослойных покрытий методом сканирующей электронной микроскопии и микроанализа обнаружено неоднородное распределение циркония, хрома, азота и молибдена по поверхности образцов. Результаты исследований показывают, что хорошие трибологические свойства в сочетании с улучшенными физико-механическими свойствами делают наплавленный материал перспективным для применения в качестве защитного материала для машин и инструментов, работающих в чрезвычайно тяжелых условиях работы.

Ключевые слова: многослойные покрытия, катодная дуга, микроструктура, двухфазное состояние, вакуумно-дуговой метод, микротвердость, износостойкость.