

A.B. Kengesbekov^{1,2}, Zh.B. Sagdoldina^{1*}, D.B. Buitkenov¹,
I.A. Ocheredko¹, S.A. Abdulina³, K. Torebek¹

¹S. Amanzholov East Kazakhstan University, Ust-Kamenogorsk, Kazakhstan

²Institute of Composite Materials, Ust-Kamenogorsk, Kazakhstan

³D. Serikbayev East Kazakhstan Technical University, Ust-Kamenogorsk, Kazakhstan

(*E-mail: sagdoldina@mail.ru)

Investigation of the characteristics of an indirect plasma torch

The main task of creating plasma technologies is to improve the operation parameters of its main element - the plasma torch, which is achieved by designing and constructing its main nodes. The paper analyzes the principles of designing a plasma torch and investigates the characteristics of an arc discharge plasma torch. The possibilities of increasing the thermal stability of the anode structure are considered; the speed and trajectory of powder particles are studied; the axial introduction of the powder through the cathode and the thermal stability of the cathode are studied. Using the finite element method, the effect of the anode shape on the service life of the plasma torch is studied by estimating the heat release power under the condition above the melting temperature of copper (anode). The optimal anode geometry for effective cooling of the unit with radial inlet and outlet of the coolant is determined. The influence of the thermal load on the cathode part of the plasma torch is studied, the thermophysical characteristics of the cathode on the operational characteristics of the plasma torch during the thermal load are taken. The dynamics of the particle by axial injection of the powder through the cathode is calculated, and the dynamics of the heating of the powder particle is determined. The output of the carrier gas is stabilized by a swirler and has great dynamics and is located in the high-temperature part of the arc. The trajectory of the movement of a powder particle in the nozzle area is calculated, which corresponds to the average value of the velocity $\approx 450-500$ m/s. It is found that an increase in the cathode diameter from 3 to 5 mm reduces the thermal load by 50%.

Keywords: plasma treatment, plasma torch, axial powder injection, aerodynamics of particle motion, thermophysical characteristics, 3D model.

Introduction

Plasma technologies occupy a worthy place in a wide range of processes that have great innovative potential but require continuous modernization and constant scientific and technical research [1]. The main task of creating plasma technologies is to improve the operating parameters of its main element - the plasma torch, which is achieved by designing and constructing its main components [2, 3]. The principles of designing a plasma torch are primarily related to the tasks of improving its functional characteristics: productivity, quality, and reliability. However, information about the functioning of the plasma torch as a whole, the design of its elements, gas-dynamic, thermophysical and electrodynamic characteristics is difficult to access [4–6].

When designing plasma torches, it is necessary, first of all, to rely on the system principle and examine the interaction of all subsystems that ensure their operation. However, among the subsystems of the plasma torch, the main functional role is played by the nozzle assembly, the design of which requires considering gas-dynamic, electrical and thermal factors of arc formation. At present, the application of methods obtained by semi-empirical methods of criterion-parametric relationships for the same type of plasma torches requires adjustments that take into account new design solutions [7]. The low thermal stability of the plasma torch units and, as a result, their short service life is an urgent problem that increases the cost of plasma technologies. Low heat resistance of the nodes also reduces the technological potential of the plasma torch, based on its purpose - the melting of refractory materials. The purpose of this work is to optimize and study the technological process of arc plasmatron. Accordingly, the following tasks are solved in this research: to increase the thermal stability of the anode design; to research the thermal stability of the cathode; to study the aerodynamics and dynamics of particles in a plasmatron with a gas swirler.

1. Research the influence of the geometry of the plasma torch anode on its performance characteristics

An urgent problem is to increase the resource of the working units of the plasma torch – the anode and cathode, which experience extreme thermal loads from the effects of low-temperature plasma of about 7000–15000 °C. The low thermal stability of the plasma torch nodes and, as a result, their short service life is an urgent problem that increases the cost of plasma technologies [8]. Figure 1 illustrates the general view of the plasmatron. The modified plasmatron has a cooled anode (1) (copper) and a cathode (2) (the cathode is inserted into a cooled cathode holder (3) interconnected through a ceramic interelectrode insert (4) [9].

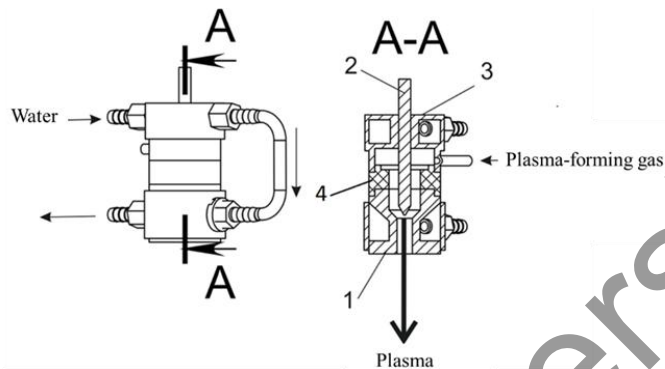

Figure 1. Plasmatron for spraying powder materials: 1 – anode, 2 – cathode, 3 – cooled cathode holder, 4 – ceramic interelectrode insert

On the program SolidWorks using the finite element method, the effect of the anode shape on the service life of the plasma torch was investigated by estimating the heat release power under the condition above the melting temperature of copper (anode). The boundary conditions for the cooled liquid in all studies for the anode are the same: water temperature 21 °C; pressure 5 atm. Figure 2 represents the geometry of the standard plasmatron anode.

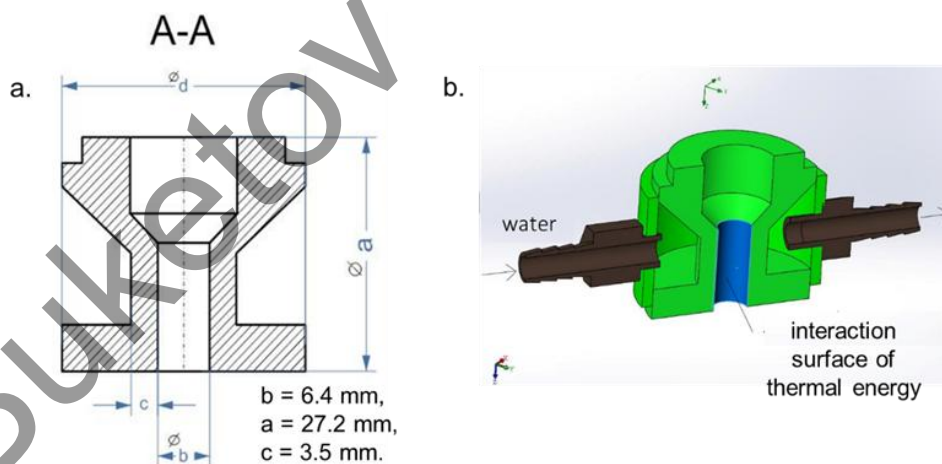

Figure 2. Anode of the plasmatron: a) scheme of the anode; b) 3D anode assembly

Figure 3 shows the graph of thermal conductivity of copper. The heat release power is a variable value. Table 1 presents the initial data on the heat load and the calculation results. The variable controlled parameter is the value – c and d , the dimensions a and b are related to the parameters of plasma formation. To avoid an increase in the dimensions of the plasmatron, dimension d had a fixed value. Going through the geometrical parameters, it is necessary to determine the maximum thermal stability of the anode depending on the geometrical parameters at the same coolant flow rate for all variants.

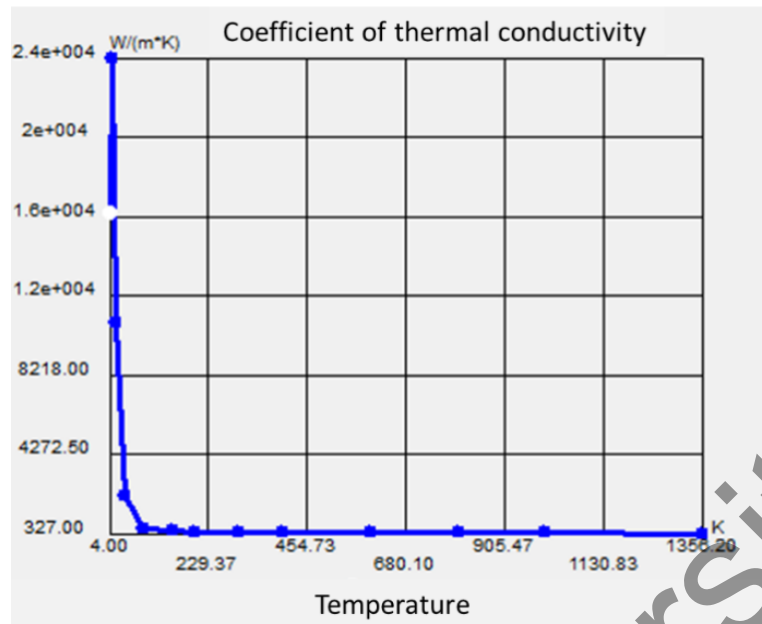

Figure 3. Graph of the thermal conductivity of copper

Table 1

Initial data on heat load and calculation results

Superheat above melting point	Design point 1	Design point 2	Design point 3	Design point 4	Design point 5
Heat dissipation capacity [W]	5000	8750	12500	16250	20000
Overheating above the melting point [°C]	-738.214219	-509.755152	-255.8967	4.706168475	260.2031197

The calculated point 4 is located near the region of the anode melting temperature. The temperature of 4.7°C above the melting point of copper, at 16250 W, is taken as a benchmark against which the results are compared when changing the anode geometry (Figure 4).

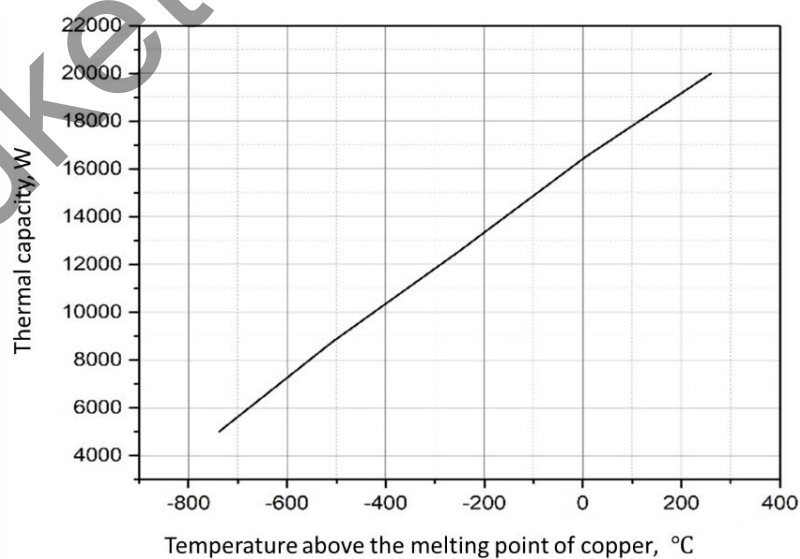

Figure 4. Overheating of the anode above the melting point of copper

Figure 5 shows different anode designs that have vertical and horizontal plates. According to a similar scheme, calculations are made for the design of the anode with a vertical plate (Figure 5a). The temperature exceeding the melting point by $4.7\text{ }^{\circ}\text{C}$ corresponds to a thermal power of 16402 W , which is a gain of 152 W and corresponds to 1% . Further studies of this anode shape seem unpromising and the following option is investigated (Figure 5b). Calculations show that an overheating temperature of $4.7\text{ }^{\circ}\text{C}$ corresponds to power of 16020 W , which amounted to a gain of 2770 W and corresponds to a 17% increase in the thermal resistance of the anode.

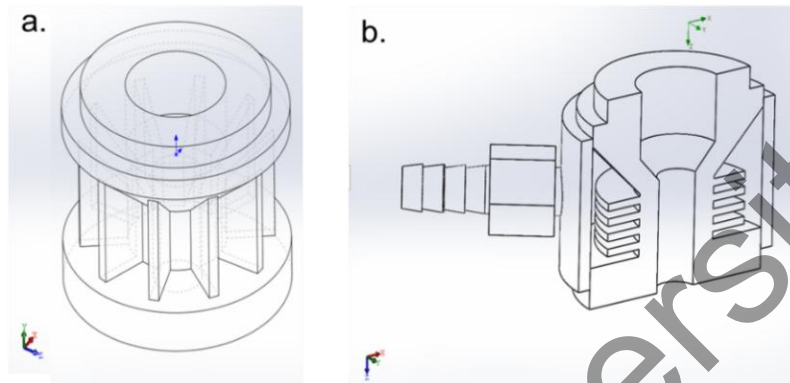

Figure 5. Anode design: a) with vertical plates; b) with horizontal plates

Figure 6 demonstrates the thermal load of 19000 W and the maximum anode temperature of $903\text{ }^{\circ}\text{C}$ (on the temperature distribution field). We can conclude that considering the safety factor of 5% , the reliable operation of the anode will make it possible to utilize 18050 W of thermal energy without thermal destruction. As noted above, this is 17% more efficient compared to the non-optimized anode geometry (Figure 2).

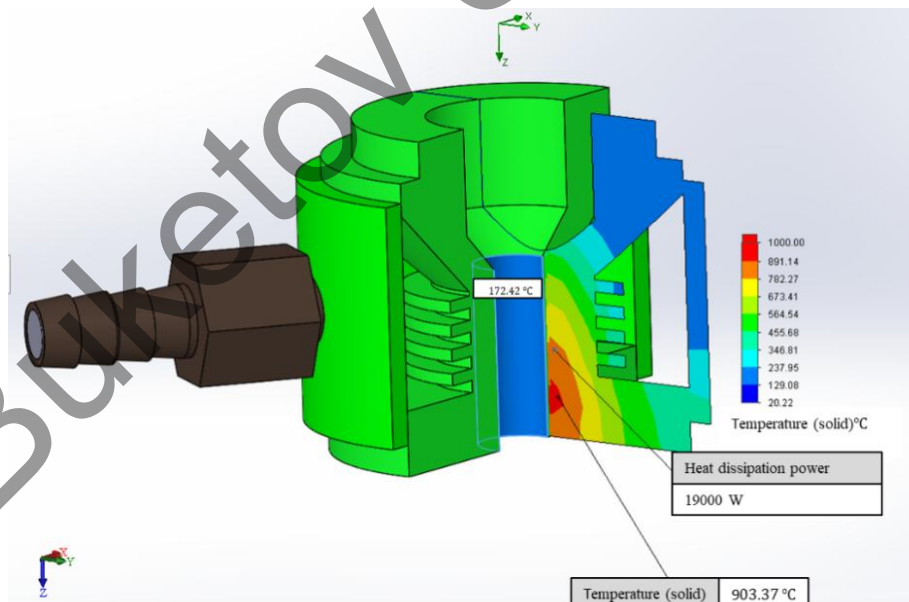

Figure 6. Anode thermal diagram

2. Research the influence of the geometry of the plasma torch anode on its performance characteristics

The cathode is the most thermally loaded part of the plasmatron; it is made of refractory tungsten with a high melting point, but low thermal conductivity relative to the copper anode. Regarding the fact that during the formation of an arc, electrons move in the direction from the anode to the cathode and, when entering the

cathode spot, cause additional heating of the cathode, the correct choice of the cathode geometry and factors affecting cooling is the number one task to ensure the continuous operation of the plasmatron. To study this problem, a 3D model of the plasma torch was created (Figure 7) and the factors affecting the operating temperature of the plasma torch were investigated.

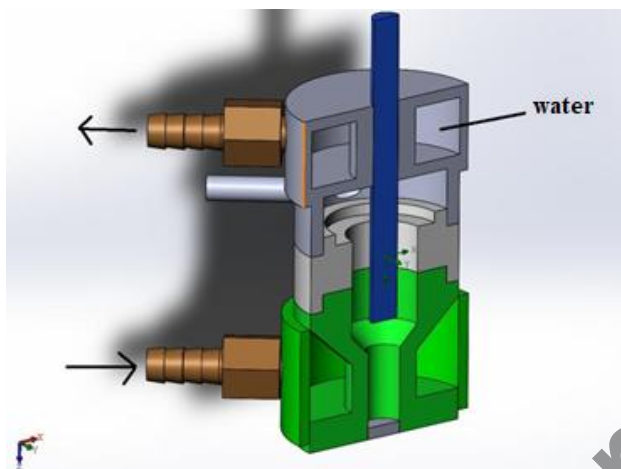

Figure 7. 3D model of the plasmatron

Figure 8 shows the dependence of the cathode temperature (at a thermal power on the cathode spot of 1 kW) on the gas pressure and cathode radius. It can be seen that with an increase in pressure from 3 to 8 atm. the temperature at the cathode drops by 550 °C (Figure 8a). The temperature dependence on the cathode size showed that an increase in the cathode radius leads to a decrease in the cathode temperature. According to Fourier’s law, the rate of heat transfer through a material is proportional to the area through which heat flows (through the cathode) [10].

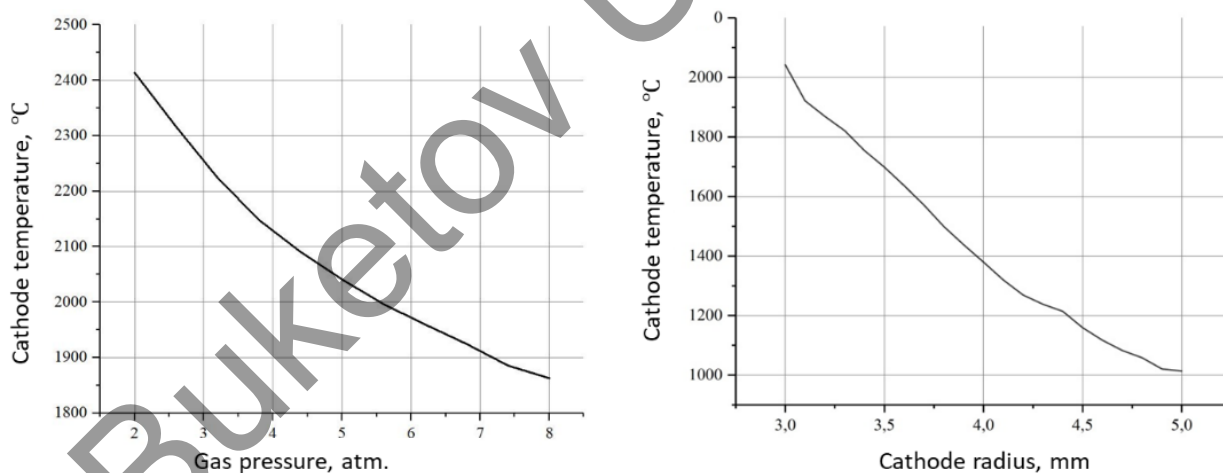

Figure 8. Dependence of the cathode temperature on gas pressure (a) and cathode radius (b)

Figure 9 shows the thermophysical characteristics (thermal conductivity, specific heat, and resistivity) of a cathode with a cooling system according to Figure 7. The plasmatron cooling system ensures the long-term operation of the cathode at a constant thermal load (Figure 10).

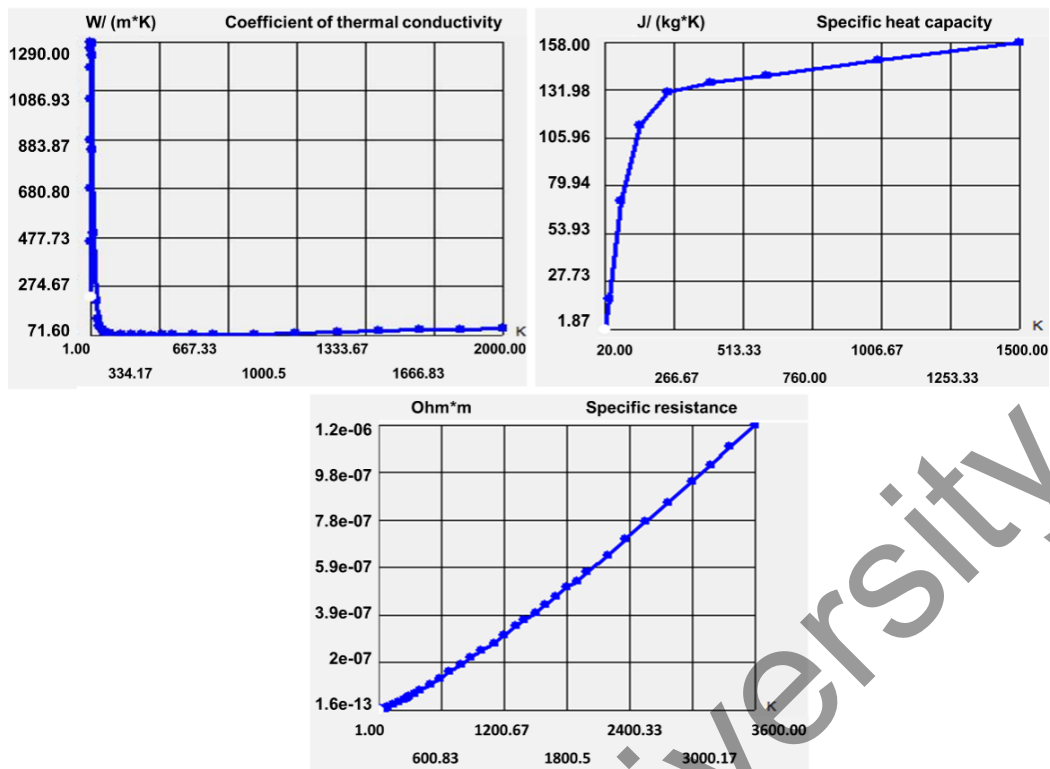

Figure 10. Thermal characteristics of the cathode

Thus, the influence of thermal load on the cathode part of the plasma torch was studied; the thermophysical characteristics of the cathode on the operational characteristics of the plasma torch during the thermal load were taken. The most significant factor affecting the reliability of the cathode is its diameter. Increasing the cathode diameter from 3 mm to 5 mm reduced the maximum temperature of the plasma torch by 50%. The second factor of influence is the pressure of the working gas. Increasing the working gas pressure by 1 atm gives a decrease in temperature by 120 °C. However, an increase in operating pressure can lead to arc failure, which leads to the need to increase the voltage and, consequently, the power of the plasma torch power source.

3. Study of the aerodynamics of particles in a plasma torch with a gas swirler

Using the finite element analysis method, the operation of a plasma torch with a gas swirler with the introduction of powder simultaneously with the working gas is studied. Figure 11a shows the gas flow trajectories and the velocity distribution gradient at an operating pressure of 5 atm. The parametric dependence of the average gas velocity on the working gas pressure at 1-8 atm is studied (Figure 11b). It can be seen that to ensure sufficient gas dynamics, it is necessary to operate the plasma torch in the pressure range of 3–5 atm.

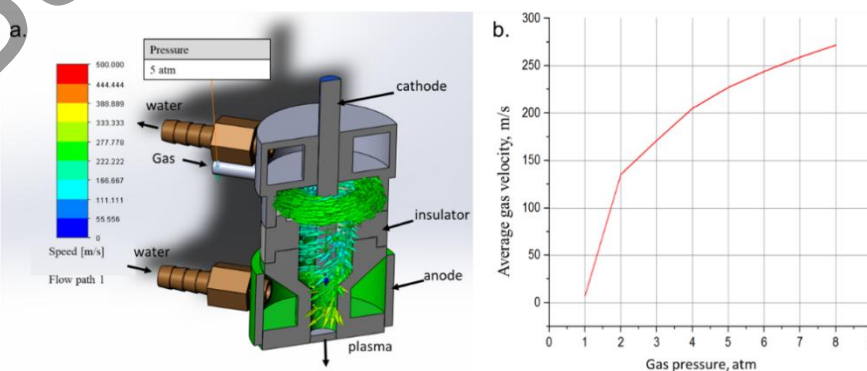

Figure 11. Results of aerodynamic modeling of the carrier gas: a) velocity distribution gradient; b) dependence of the average gas velocity on the operating gas pressure

Then the dynamics and trajectories of the movement of powder particles are studied when it is introduced into the swirler channel. The study is carried out without conditions of sticking and erosion. Titanium nitride fraction $5\ \mu\text{m}$ is chosen as the powder (conditional powder consumption $0.005\ \text{kg/s}$). The trajectory of the movement of a powder particle to the nozzle area is calculated, which corresponds to an average velocity of $\approx 220\ \text{m/s}$, as shown in Figure 12b. The length of the particle path in the plasma torch is up to $500\ \text{mm}$, in the plasma zone (nozzle area) about $150\ \text{mm}$.

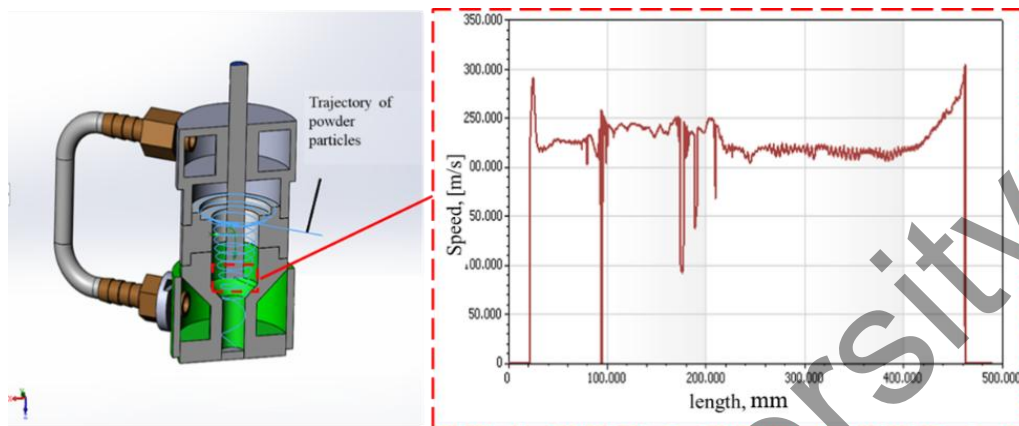

Figure 12. The results of the study of the speed of powder particles: a) the trajectory of the powder particle; b) the speed of movement of a particle of titanium nitride in the plasma torch

A scheme with axial injection of powder through the cathode is investigated (Figure 13). The aerodynamics of this scheme is calculated, the pressure of the working gas in the swirler is $5\ \text{atm}$, and in the cathode axis is $5\ \text{atm}$. The carrier gas outlet is stabilized by the swirler and has high dynamics; it is located in the high-temperature part of the arc (Figure 13b). The flow rate of the transporting gas in the anode area is $445\text{--}500\ \text{m/s}$.

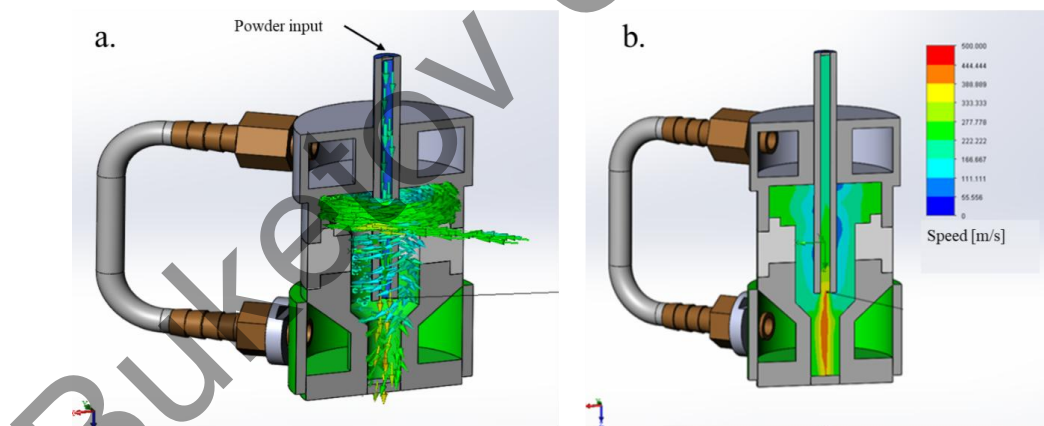

Figure 13. 3D model with axial injection of powder through the cathode (a) and the flow rate (b) of the transporting gas in the plasma torch

Figure 14 shows the velocity gradient and trajectory of the powder particles as the powder is axially injected through the cathode. The study is carried out without conditions of sticking and erosion. Titanium nitride with a fraction of $5\ \mu\text{m}$ was chosen as the powder, at a material consumption of $0.005\ \text{kg/s}$. The trajectory of the movement of a powder particle to the nozzle area is calculated, which corresponds to an average velocity of $\approx 450\text{--}500\ \text{m/s}$.

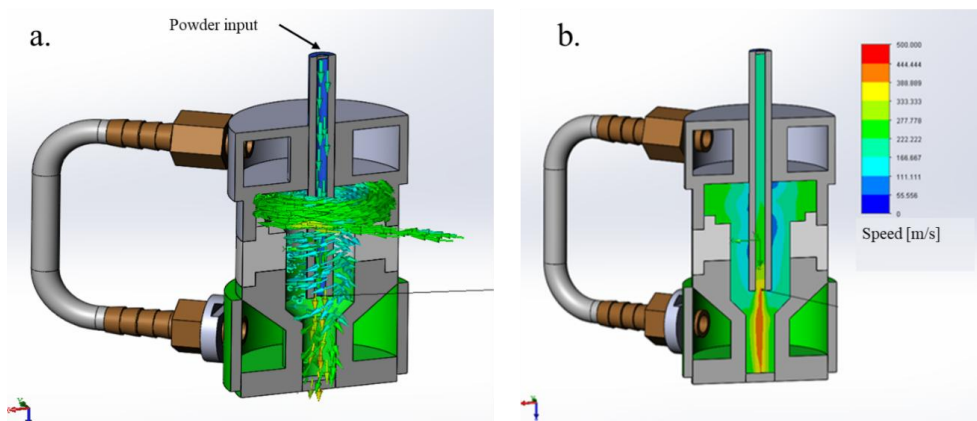

Figure 14. Velocity gradient of powder particles in the plasma torch

The particle dynamics along the motion trajectory is calculated (Figure 15a) and the particle heating dynamics is determined (Figure 15b). A domain in the form of a plasma arc with a temperature of 6000 °C is installed in the plasma torch. It can be seen from the diagrams that the particles move in the axis of the arc and the path length is equal to the length of the arc.

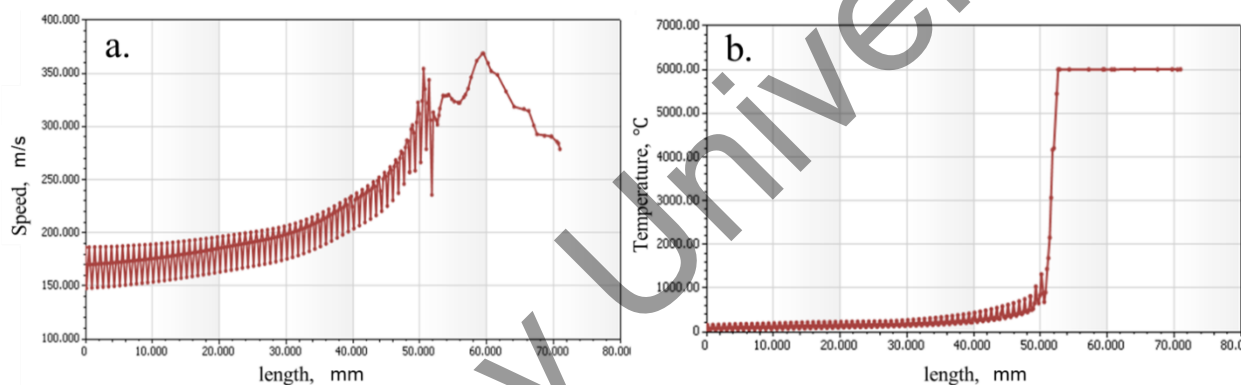

Figure 15. Particle dynamics along the motion trajectory (a) and particle heating dynamics (b)

Conclusions

Analyzing the experimental results obtained in the work, we draw the following conclusions:

- The optimal anode geometry for efficient cooling of the unit with radial inlet and outlet of the coolant was determined. The optimized anode design is 17% more efficient than the standard plasma torch anode geometry. This will increase the anode resource, operating currents, and expand the technological potential of the plasma torch;
- It was found that an increase in the cathode diameter from 3 to 5 mm reduces the thermal load by 50%. An increase in the working pressure of the gas by 1 atm gives a decrease in temperature by 120 °C. However, an increase in operating pressure can lead to arc breakdown, which leads to the need to increase the voltage and, consequently, the power of the plasma torch power source;
- The scheme with powder injection along the cathode axis makes it possible to effectively use the efficiency of the plasma torch and ensures an uninterrupted plasma treatment process.

Acknowledgment

This research was funded by the Science Committee of the Ministry of Education and Science of the Republic of Kazakhstan (Grant No. AP08857800).

References

- 1 Rakhadilov B. Hydrogen and deuterium storage in tungsten when irradiation with Plasma beam / B. Rakhadilov, A. Kenesbekov, M. Skakov, A. Miniyov // In METAL 2018-27th International Conference on Metallurgy and Materials, Conference Proceedings. — P. 1216–1221.
- 2 Chen Xi. Three-dimensional flow and heat transfer in thermal plasma systems / Xi. Chen, H. Li. // Surface and Coatings Technology. — 2003. — Vol. 171. — P. 124–133.
- 3 Gawne D.T. Modelling of plasma–particle two-phase flow using statistical techniques / D.T. Gawne, B. Liu, Y. Bao, T. Zhang // Surface and Coatings Technology. — 2005. — Vol. 191. — P. 242–254.
- 4 Ramachandran K. 3D modeling of plasma–particle interactions in a plasma jet under dense loading conditions / K. Ramachandran, N. Kikukawa, H. Nishiyama // Thin Solid Films. — 2003. — Vol. 435. — P. 298–306.
- 5 Trelles J.P. Multiscale finite element modeling of arc dynamics in a DC plasma torch / J.P. Trelles, P. Emil, H. Joachim // Plasma chemistry and plasma processing. — 2006. — Vol. 26.6. — P. 557–575.
- 6 Park J. Two-dimensional numerical modeling of direct-current electric arcs in nonequilibrium. / J. Park, J. Heberlein, E. Pfender, G. Candler, C.H. Chang // Plasma Chemistry and Plasma Processing. — 2008. — Vol. 28.2. — P. 213–231.
- 7 Анахов С.В. Принципы и методы проектирования плазмотронов: моногр. / С.В. Анахов. Екатеринбург: Изд-во Рос. гос. проф.-пед. ун-та, 2018. — 165 с.
- 8 Kylyshkanov M.K. Processing of industrial waste by plasma-chemical method / M.K. Kylyshkanov, K.A. Shestakov, Z.B. Sagdoldina, B.K. Rakhadilov, A.B. Kengesbekov // Bulletin of the university of Karaganda-Physics. — 2021. — Vol. 3, No. 103. — P. 45–51.
- 9 Rakhadilov B.K. Development of air-plasma technology for hardening cutting tools by applying wear-resistant coatings / B.K. Rakhadilov, A.B. Kenesbekov, P. Kowalevski, Y.A. Ocheredko, Sagdoldina Zh.B. // News of the National Academy of sciences of the Republic of Kazakhstan-series of geology and technical sciences. — 2020. — Vol. 3.441. — P.54–62.
- 10 Bird R.B. Transport Phenomena / R.B. Bird, W.E. Stewart, E.N. Lightfoot // Wiley. — 2006. — Vol. 1. ISBN 978-0-470-11539-8.

А.Б. Кеңесбеков, Ж.Б. Сағдолдина, Д.Б. Буйткенов,
И.А. Очередько, С.А. Абдулина, К. Төрбек

Жанама әсер ететін плазмотрон сипаттамасын зерттеу

Плазмалық технологияларды құрудың негізгі міндеті оның негізгі элементі — плазмотрон жұмысының параметрлерін жақсарту болып табылады, оған оның негізгі түйіндерін жобалау және құрау арқылы қол жеткізіледі. Мақалада плазмотронды жобалау принциптері және доғалық разряд плазмотронының сипаттамалары талданған. Анод құрылымының жылу тұрақтылығын арттыру мүмкіндіктері қарастырылған, ұнтақ бөлшектерінің жылдамдығы мен траекториясы зерттелді, катод арқылы ұнтақты осьтік енгізу, катодтың жылу кедергісі зерттелген. Соңғы элементтер әдісімен мыстың (анодтың) балку температурасынан жоғары болған жағдайда жылу шығару қуатын бағалау бойынша анод формасының плазмотрон жұмысының ресурсына әсері тексерілген. Салқындатқышты радиалды енгізу және шығару кезінде түйінді тиімді салқындату үшін анодтың оңтайлы геометриясы анықталды. Жылу жүктемесінің плазмотронның катодты бөлігіне әсері зерттелді, жылу жүктемесі процесінде катодтың жылу-физикалық сипаттамалары плазмотронның пайдалану сипаттамаларына алынды. Бөлшектің динамикасы катод арқылы ұнтақты осьтік енгізу арқылы есептеледі және ұнтақ бөлшегінің қыздыру динамикасы анықталады. Тасымалдаушы газдың шығуы турбулентті тұрақтандырады және үлкен динамикаға ие және доғаның жоғары температуралық бөлігінде орналасқан. Ұнтақ бөлшегінің саптама аймағына қозғалысының траекториясы есептеледі, ол жылдамдықтың орташа мәніне сәйкес келеді $\approx 450-500$ м/с. Катод диаметрінің 3-тен 5 мм-ге дейін ұлғаюы жылу жүктемесін 50% төмендететіні анықталды.

Кілт сөздер: плазмалық өңдеу, плазмотрон, ұнтақты осьтік енгізу, бөлшектердің қозғалысының аэродинамикасы, термофизикалық сипаттамалары, 3D моделі.

А.Б. Кеңесбеков, Ж.Б. Сағдолдина, Д.Б. Буйткенов,
И.А. Очередько, С.А. Абдулина, К. Төрбек

Исследование характеристики плазмотрона косвенного действия

Основной задачей создания плазменных технологий является улучшение параметров работы основного ее элемента — плазмотрона, что достигается путем проектирования и конструирования его основных узлов. В статье проанализированы принципы проектирования плазмотрона и исследованы характеристики плазмотрона дугового разряда. Были рассмотрены возможности увеличения термической стойкости конструкции анода, изучена скорость и траектория частиц порошка, осевым

вводом порошка через катод, исследована термостойкость катода. Методом конечных элементов исследовано влияние формы анода на ресурс работы плазмотрона по оценке мощности тепловыделения при условии выше температуры плавления меди (анода). Определена оптимальная геометрия анода для эффективного охлаждения узла при радиальном вводе и выводе охлаждающей жидкости. Были исследованы влияния термической нагрузки на катодную часть плазмотрона, сняты теплофизические характеристики катода на эксплуатационные характеристики плазмотрона в процессе термической нагрузки. Рассчитана динамика частицы осевым вводом порошка через катод и определена динамика разогрева частицы порошка. Выход транспортирующего газа стабилизирован завихрителем и имеет большую динамику и находится в высокотемпературной части дуги. Вычислена траектория движения частицы порошка в область сопла, который соответствует среднему значению скорости $\approx 450\text{--}500$ м/с. Выявлено, что увеличение диаметра катода с 3 до 5 мм снижает термическую нагрузку на 50 %.

Ключевые слова: плазменная обработка, плазмотрон, осевой ввод порошка, аэродинамика движения частиц, теплофизические характеристики, 3D-модель.

References

- 1 Rakhadilov, B., Kenesbekov, A., Skakov, M., & Miniyzov, A. (2018). Hydrogen and deuterium storage in tungsten when irradiation with Plasma beam. In *METAL 2018-27th International Conference on Metallurgy and Materials, Conference Proceedings*, 1216–1221.
- 2 Chen, Xi., & Li., H. (2003). Three-dimensional flow and heat transfer in thermal plasma systems. *Surface and Coatings Technology*, 171, 124–133.
- 3 Gawne, D.T., Liu, B., Bao, Y., & Zhang, T. (2005). Modelling of plasma–particle two-phase flow using statistical techniques. *Surface and Coatings Technology*, 191, 242–254.
- 4 Ramachandra, K., Kikukawa, N., & Nishiyama, H. (2003). 3D modeling of plasma–particle interactions in a plasma jet under dense loading conditions. *Thin Solid Films*, 435, 298–306.
- 5 Trelles, J.P., Emil, P., & Joachim, H. (2006). Multiscale finite element modeling of arc dynamics in a DC plasma torch. *Plasma chemistry and plasma processing*, 26.6, 557–575.
- 6 Park, J., Heberlein, J., Pfender, E., Candler, G., & Chang, C.H. (2008). Two-dimensional numerical modeling of direct-current electric arcs in nonequilibrium. *Plasma Chemistry and Plasma Processing*, 28.2, 213–231.
- 7 Anakhov, S.V. (2018). Printsipy i metody proektirovaniia plazmotronov [Principles and methods of plasma torch design]. *Monography*. Ekaterinburg: Izdatelstvo Rossiiskogo gosudarstvennogo professionalno-pedagogicheskogo universiteta [in Russian].
- 8 Kylyshkanov, M.K., Shestakov, K.A., Sagdoldina, Z.B., Rakhadilov, B.K., & Kengesbekov, A.B. (2021). Processing of industrial waste by plasma-chemical method. *Bulletin of the university of Karaganda-Physics*, 3(103), 45–51.
- 9 Rakhadilov, B.K., Kenesbekov, A.B., Kowalevski, P., Ocheredko, Y.A., & Sagdoldina, Zh.B. (2020). Development of air-plasma technology for hardening cutting tools by applying wear-resistant coatings. *News of the National Academy of sciences of the Republic of Kazakhstan-series of geology and technical sciences*, 3(441), 54–62.
- 10 Bird, R.B. Stewart, W.E., & Lightfoot, E.N. (2006). *Transport Phenomena*. Wiley, 1, ISBN 978-0-470-11539-8.