

A.E. Goldshteyn, Kh.Kh. Abakumov

*National Research Tomsk Polytechnic University, Russia
(E-mail: algol@tpu.ru)*

The use of a two-frequency eddy current method for measuring the electrically conductive wall thickness under significant variations in the test parameter and the lift-off

The paper addresses the problem of eddy current testing of the wall thickness of light-alloy drill pipes under significant variations in both the test and the influence parameter of the test object – the lift-off between the eddy current probe and the test object surface. The performance of the two-frequency eddy current method is shown through the use of the signal of the surface eddy current probe of the added high-frequency voltage amplitude as an informative parameter to measure the lift-off and the phase of the added low-frequency voltage. Experimentally obtained dependences of the informative parameters on test and influence parameters are presented. The phase and amplitude-phase multi-parameter methods used to suppress the effect of stray parameters in eddy current testing are analyzed; the effectiveness of their application under significant variations in test and other influence parameters of the test object is shown to be limited. The effectiveness of nonlinear functions for the inverse transformation of the informative parameter into the test parameter to suppress the lift-off effect on test results is estimated. Criteria of choice for informative parameters of the eddy current probe signal are considered. The measurement error caused by the approximation error of the nonlinear functions of the inverse transformation of the informative parameters into the test parameter within the variation ranges of the test and influence parameters is estimated.

Keywords: thickness measurement, surface eddy current probe, signal hodographs, stray parameters, suppression in eddy current testing.

Introduction

One of the important tasks of eddy current testing effectively tackled with surface eddy current probes (ECP) is to measure the wall thickness of pipes made from electrically conductive non-magnetic materials, as well as the thickness of the dielectric coatings of these pipes or the lift-off between the ECP and the pipe surface. A practical example of using the surface ECP is the measurement of the wall thickness of light-alloy drill pipes (LADP) made from D16T duralumin.

Measurement of the wall thickness of electrically conductive pipes using the surface ECP in real inspection is complicated due to possible significant variations in the wall thickness t and the lift-off h between the ECP and the pipe surface, as well as due to the specific electrical conductivity σ of the pipe material and significant impact of these factors on the informative parameters of the ECP signal. These test problems can be solved using well-proven multi-frequency eddy current methods.

The study object is a two-frequency eddy current method used to test the wall thickness of an electrically conductive pipe. The subject of the study is the assessment of its applicability under significant variations in both the test parameter and other influence parameters.

The study aimed to reveal the dependence of the ECT signal on the influence parameters, to choose the informative parameters of the ECP signal, and to choose a method and evaluate its effectiveness for suppression of stray factors, suppression of the lift-off effect in particular. Suppression of the impact of variations in electrical conductivity will be considered in a separate study.

Experimental

Figure 1 schematically shows the design of the surface transformer ECP used in the study, which is supplied with the excitation winding w_1 , measuring winding w_{21} and compensation winding w_{22} . An opposite connection of the measuring and compensating windings in the absence of the test object mutually compensate their initial EMF. An electrically conductive test object located near the ECP causes a signal at the ECP output due to eddy currents generated in the object. In the general case, the amplitude and phase (complex components) of the applied EMF are determined by the amplitude and frequency of the excitation current, ECP design parameters, electromagnetic characteristics of the material and geometric parameters of the test object, and the relative position of the ECP and the test object.

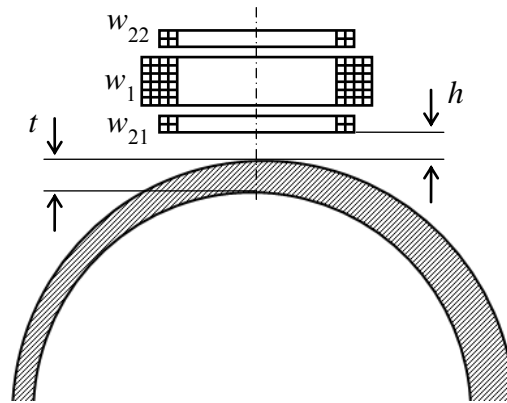

Figure 1. Surface ECP over an electrically conductive pipe

The test object was a pipe made from non-magnetic material with a specific electrical conductivity $\sigma = 16 \text{ MSm/m}$, with a nominal outer diameter $D = 147 \text{ mm}$ and a wall thickness t in the range of (5...12) mm. The distance between the ECP measuring winding and the pipe surface varied in the range of (2...12) mm.

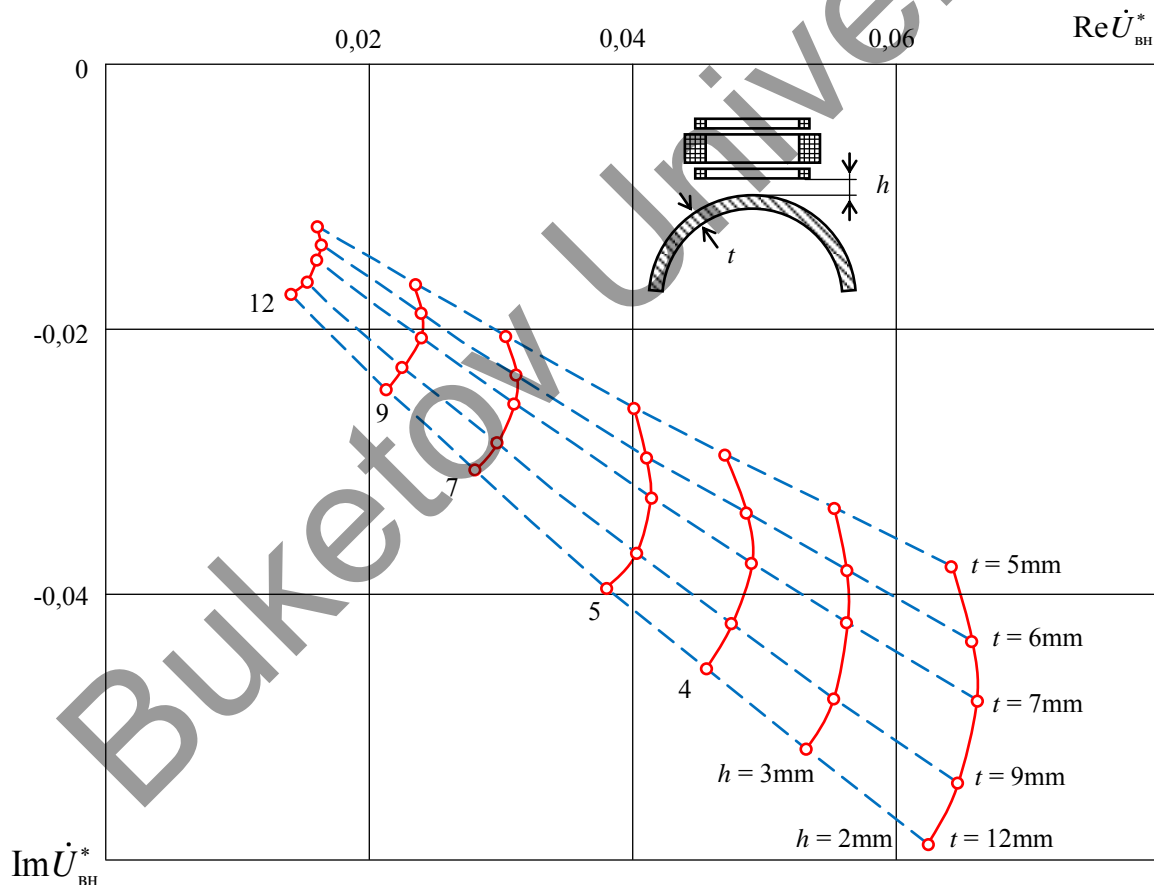

Figure 2. Hodographs of the added relative voltage of the ECP versus variations in the pipe wall thickness and the lift-off

It should be noted that under a wide range of variations in the influence parameters, a higher accuracy of determining the functions of transformation of the influence parameters into the ECP signal informative parameters is required to achieve a high accuracy in the wall thickness measurement with a relative error of less than 3%. The applied mathematical models [1–4] do not provide the required accuracy. Therefore, physical modeling was used to find the transform functions.

During the experiments, a surface ECP with the following structural parameters was used: 40 mm outer diameter of the excitation winding; 32 mm inner diameter of the excitation winding; 10 mm height of the excitation winding; 30 mm diameter of the middle turn of the measuring and compensation windings; 16 mm distance between the planes of the middle turns of the measuring and compensation windings located symmetrically with respect to the excitation winding.

Physical modeling was performed using the SVK-03 eddy current testing system developed at Tomsk Polytechnic University School of Nondestructive Testing to find functional dependencies of the ECP added voltage on the main influence parameters of the electrically conductive test object using different ECPs and excitation current frequencies. The system provides the measurement of the ECP added voltages in the specified ranges of influence parameter variations with a relative error not exceeding 1%.

Figure 2 shows hodographs of the added relative voltage of the ECP versus variations in the pipe wall thickness (solid lines) and the lift-off (dashed lines) for 125 Hz excitation frequency.

At the next stage, informative parameters of the ECP signal were chosen, and the degree of their dependence on the measured and other influence parameters was analyzed. The amplitude of the added voltage [1, 2], the phase of the added voltage [5, 6], both the amplitude and phase of the added voltage [7] and complex components of the added voltage [8, 9] are used as informative parameters to solve various problems of eddy current testing.

When choosing the informative parameter, the main criteria are high sensitivity to the test parameter as compared to the sensitivity to other influence parameters and the monotonicity of the transform function. In most cases of eddy current testing of the electrically conductive wall thickness, the added voltage phase is used as the ECP signal informative parameter [5, 6]. The compliance of this choice with the above criteria can be illustrated based on the analysis of the results presented in Figure 2.

Results and Discussion

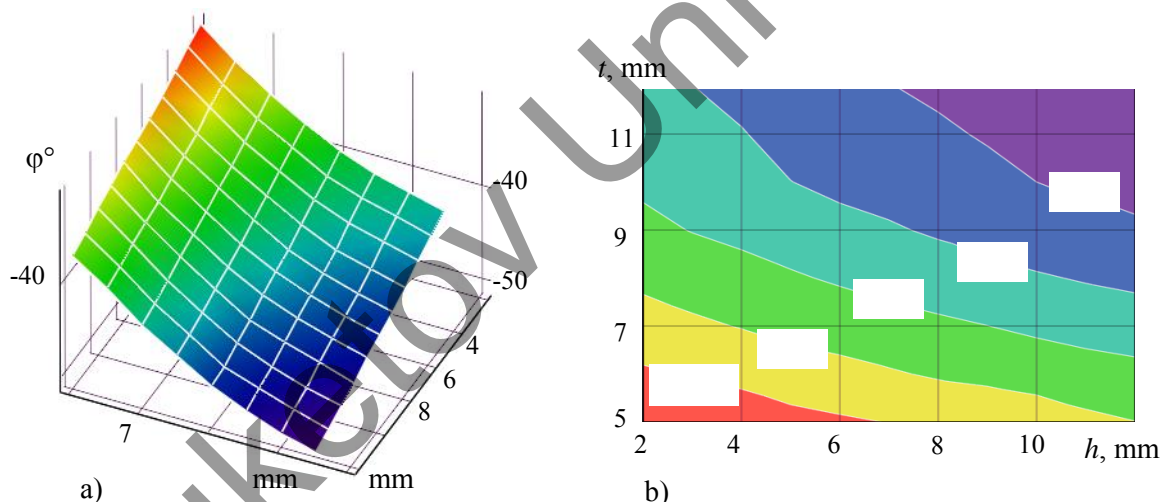

Figure 3. Dependence of the added voltage phase φ on the wall thickness t and the lift-off h : surface plot (a) and level lines of the function $\varphi(t, h)$ (b)

Figure 3 presents the dependence of the added voltage phase on the wall thickness t and the lift-off h , which is a function of two parameters $\varphi(t, h)$. The surface plot (a) illustrates the monotonicity of the dependence $\varphi(t)$, and the level line plot (b) shows a higher sensitivity of the function $\varphi(t, h)$ to the t value variation as compared to its sensitivity to the h value variation. The ratio of the indicated sensitivities corresponds to the tangent of the angle α between the level line (Figure 3b) and the coordinate axis t . If φ does not depend on h , $\alpha \rightarrow \pi/2$ and $\text{tg } \alpha \rightarrow \infty$.

For comparison, Figure 4 shows the dependence of the added relative voltage amplitude on the wall thickness t and the lift-off h . Analysis of the dependence reveals a low sensitivity of the function $A^*(t, h)$ to the t value variation as compared to its high sensitivity to the h value variation and monotonicity of the dependence $A^*(h)$. This indicates that the A^* value is an informative parameter appropriate for measuring the lift-off (thickness of a non-conductive coating) and inappropriate for measuring the thickness of the electrically conductive wall.

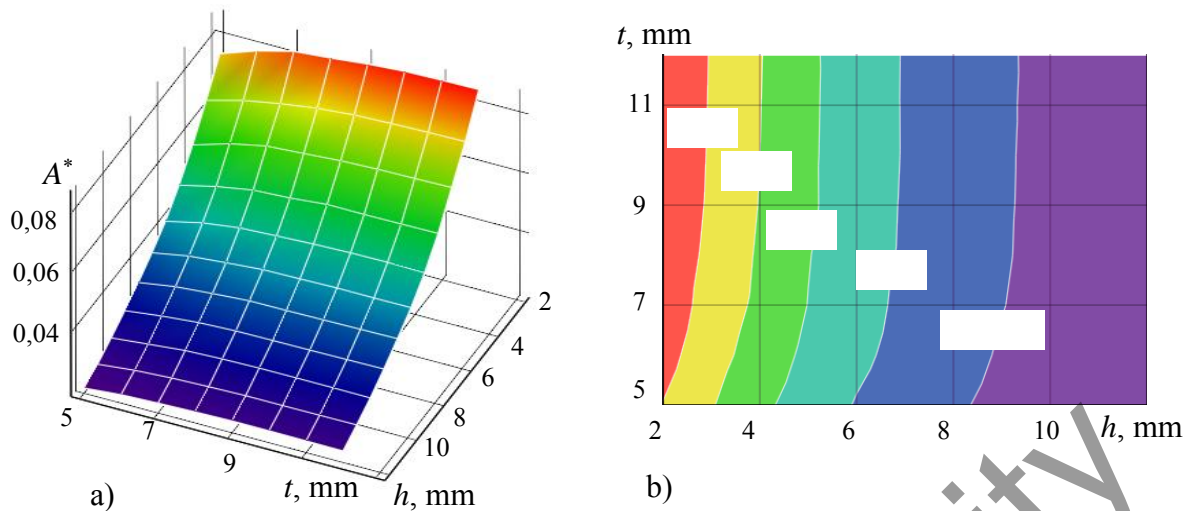

Figure 4. Dependence of the added relative voltage amplitude A^* on the wall thickness t and the lift-off h : surface plot (a) and level lines of the function $A^*(t, h)$ (b)

It should be noted that the dependence of the phase on the lift-off $\varphi(h)$ is relevant for high measurement accuracy when using the added voltage phase $\varphi(t)$ to measure the thickness t of the electrically conductive wall as an informative parameter of the ECP signal. Therefore, the impact of the lift-off h variations on the testing results should be suppressed to effectively measure the thickness t .

The main suppression methods for solving the considered problem are phase [4, 5] and amplitude-phase [1, 2, 9] methods. However, as shown in [7, 8, 10], conventional methods used to suppress the impact of stray parameters do not always provide the desired results. This is because the effective suppression of the influence parameter when using the above suppression methods is possible only if the hodograph of the added voltage versus the parameter variation is a straight line [2, 8]. This can be achieved only in small variation ranges of both measured and influence parameters [9].

The specified limitation can be reduced by nonlinear methods for processing the ECP signal, along with multifrequency excitation of eddy currents [8, 11]. Let us consider a two-frequency eddy current thickness gauge for the wall of light-alloy drill pipes as an example of practical implementation of this method for suppressing influence parameters [12].

To effectively perform testing, the excitation current frequency of the ECP of the eddy current thickness gauge was chosen so that at a high frequency f_1 the penetration depth of the magnetic field was approximately equal to half the wall thickness, and at a low frequency f_2 it exceeded the wall thickness. In this case, the added voltage of the ECP at the first frequency depends on the lift-off h and the specific electrical conductivity of the material σ , and the added voltage at the second frequency depends on the lift-off h , the specific electrical conductivity of the material σ and the wall thickness t .

Data on the wall thickness can be obtained by measuring the added low-frequency voltage phase. In this case, the influence parameters are the lift-off variation and the material-specific electrical conductivity variation, which to a lesser extent affect the value of the added voltage phase. As already indicated, this study considers suppression of the lift-off effect only.

The indicated suppression can be performed using the function of inverse transformation of the relative value of the added high-frequency voltage amplitude A_1 into the value of the lift-off h , which is determined by the numerical analysis of the experimental dependence of the amplitude A_1 on the lift-off h . This dependence with an accuracy sufficient for efficient testing is approximated by the function

$$h = b \ln \left(\frac{A_1}{A_{10}} \right),$$

where b is a coefficient that depends on the outer diameter of the pipe, design parameters of the ECP and the lift-off h variation range; A_{10} is the amplitude value at the minimum h value (determined during setting of the thickness gauge before measurements).

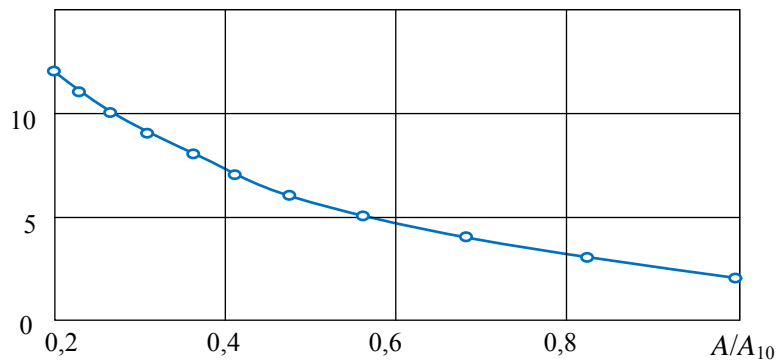

Figure 5. Function of transformation of the relative value of the added high-frequency voltage amplitude A_1 into the lift-off h

Figure 5 presents the plot of the function $h(A_1)$ for the excitation current frequency of 2500 Hz and previously indicated parameter values of the ECP and the test object.

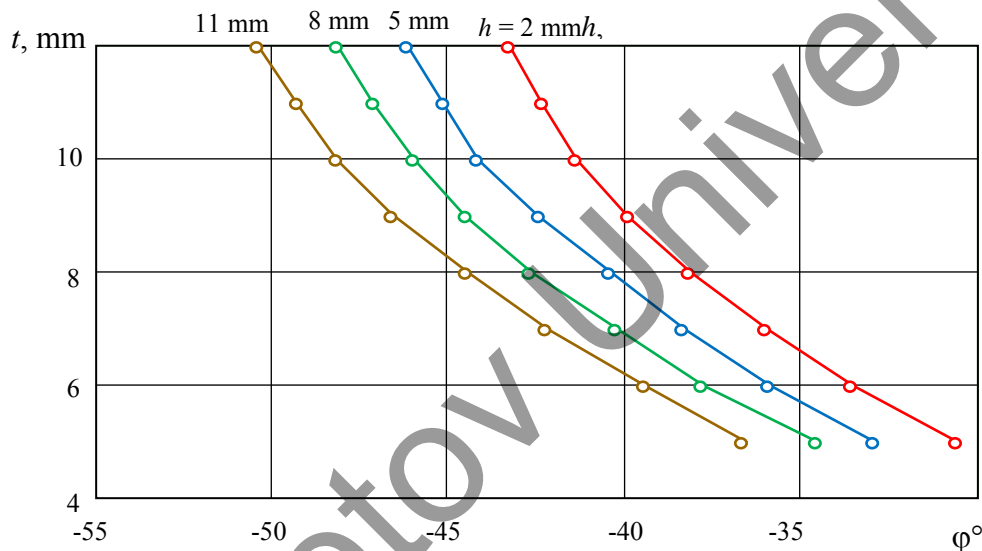

Figure 6. Function of inverse transformation of the added low-frequency voltage phase φ_2 into the pipe wall thickness t for different values of the lift-off h

To determine the desired value of the test parameter, the functional dependence of the pipe wall thickness $t(h, \varphi_2)$ on the lift-off h and low frequency phase φ_2 is used (Figure 6). These functions are approximated by the third-degree polynomials with a sufficient degree of accuracy.

To determine the t value, the discrete values h_i and h_{i+1} corresponding to the thicknesses of the test objects used to determine the dependence presented in Figure 6, which are closest to the measured h value, are first determined. Next, the corresponding values $t_i(h_i, \varphi_2)$ and $t_{i+1}(h_{i+1}, \varphi_2)$ are calculated.

The t value is calculated under the assumption of linearity in a small range of the lift-off h variation in the dependence $t(h)$:

$$t = t_i(h_i, \varphi_2) + \frac{t_{i+1}(h_{i+1}, \varphi_2) - t_i(h_i, \varphi_2)}{h_{i+1} - h_i} (h - h_i).$$

To assess both the quality of suppression of the lift-off variation effect for the measurement result of the pipe wall thickness and the component of the measurement error caused by the approximation error of non-linear functions of the inverse transformation of the informative parameter into the test parameter, the thickness was measured in the indicated variation ranges of the pipe wall thickness and the lift-off.

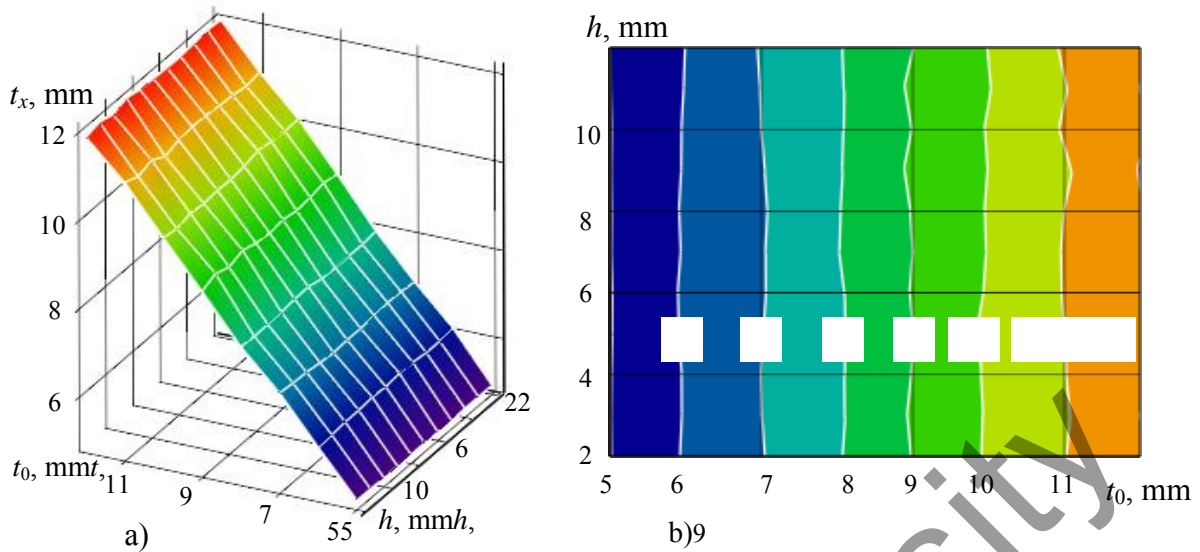

Figure 7. Dependence of the measured wall thickness t_x on the actual value of the wall thickness t_0 and the lift-off h : surface plot (a) and level lines of the function $t_x(t_0, h)$ (b)

Figure 7 presents the measurement results as the dependences of the measured wall thickness t_x on the actual value of the wall thickness t_0 and the lift-off h in the variants of the surface plot (a) and level lines of the function $t_x(t_0, h)$ (b). The plot of the level lines most apparently represents the measurement error. It is evidenced by the mismatch of the level lines (lines of a similar wall thickness) with vertical grid lines.

Figure 8 presents the obtained dependence of the measurement error on the wall thickness t and the lift-off h . The analysis of the dependence shows that this component of the absolute error in the main ranges of the test and influence parameter variations does not exceed ± 0.1 mm.

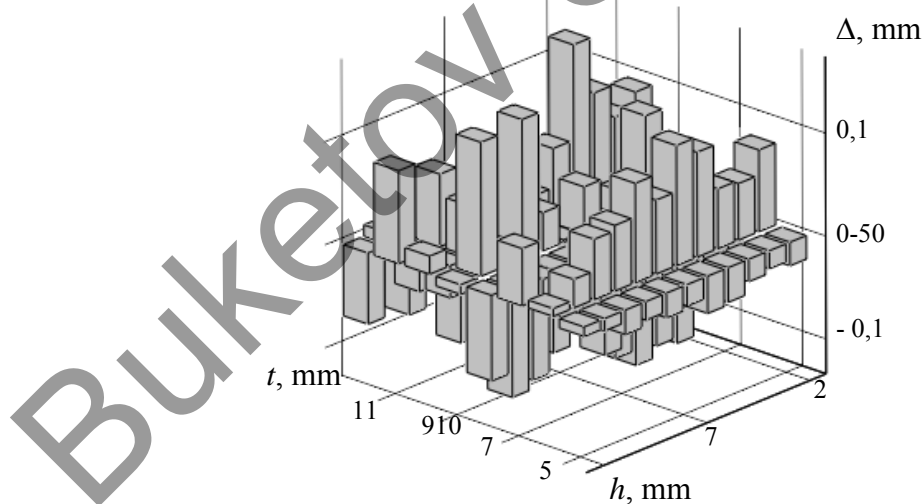

Figure 8. Dependence of the measurement error on the wall thickness t and the lift-off h

Conclusions

Analysis of the results obtained in the study of the two-frequency method for testing the wall thickness of light-alloy drill pipes proved its feasibility under significant variations in both the test parameters and other influence parameters. The requirements for choosing the informative parameters of the ECT signal are presented. The effectiveness of non-linear functions for the inverse transformation of the informative parameter into the test parameter was estimated to suppress the impact of the lift-off variations on the wall thickness measurement results. Due to the error in the approximation of the inverse transformation functions in

the established ranges of variations in the test and influence parameters, the measurement error does not exceed tenths of a millimeter, which is acceptable for solving a wide range of practical tasks.

References

- 1 Неразрушающий контроль. Справочник: [В 7 т.]. — Т. 2: [В 2-х кн.]. — Кн. 1. Контроль герметичности. — Кн. 2. Вихретоковый контроль / В.В. Ключев. — М.: Машиностроение, 2003. — 688 с.
- 2 Шубочкин А.Е. Развитие и современное состояние вихретокового метода неразрушающего контроля: моногр. / А.Е. Шубочкин. — М.: Изд. дом «Спектр», 2014. — 288 с.
- 3 Xuefei M. Analytical solutions to eddy current field excited by a probe coil near a conductive pipe / M. Xuefei, L. Yinzhao // NDT&E International. — 2013. — No. 54. — P. 69 — 74.
- 4 Aikeyeva A.A. Modeling electromagnetic systems / A.A. Aikeyeva, B.A. Zhautikov, A.M. Aidarkhanov, A.S. Zhanasbayeva, F.B. Zhautikov, A.S. Belgibayev // Bulletin of the university of Karaganda-Physics. — 2014. — 75. — No. 3. — P. 28–34.
- 5 Сясько В.А. Измерение толщины стенок изделий из углеродных композиционных материалов с использованием вихретокового фазового метода / В.А. Сясько, Д.Н. Чертов, А.Е. Ивкин // Дефектоскопия. — 2011. — № 8. — С. 76–84.
- 6 Сясько В.А. Измерение толщины покрытий из драгоценных металлов с использованием вихретокового вида контроля / В.А. Сясько, А.Е. Ивкин // В мире неразрушающего контроля. — 2012. — 56. — № 2. — С. 22–25.
- 7 Атавин В.Г. Отстройка от электропроводности основания при измерении толщины токопроводящих покрытий методом вихревых токов / В.Г. Атавин, А.А. Узких, Р.Р. Исхужин // Дефектоскопия. — 2018. — № 1. — С. 58–64.
- 8 Тетерко А.Я. Метод многопараметровых вихретоковых измерений толщины, электропроводности материала и толщины диэлектрического покрытия элементов конструкций / А.Я. Тетерко, В.И. Гутник, Г.Г. Луценко, А.А. Тетерко // Техническая диагностика и неразрушающий контроль. — 2014. — № 3. — С. 55–60.
- 9 Егоров А.В. Вихретоковый контроль металлических материалов с помощью проекционных методов многомерного анализа данных / А.В. Егоров, В.В. Поляков // Дефектоскопия. — 2018. — № 5. — С. 55–62.
- 10 Бакунов А.С. Развитие вихретоковой толщинометрии защитных покрытий / А.С. Бакунов, В.А. Калосин // Контроль. Диагностика. — 2016. — № 1. — С. 27–31.
- 11 Федосенко Ю.К. Основы нелинейной теории многопараметрового вихретокового контроля металлических объектов / Ю.К. Федосенко // Дефектоскопия. — 1981. — № 6. — С. 38–45.
- 12 Goldshteyn A.E. An eddy-current gauge for measuring the wall thickness of light-alloy drill pipes / A.E. Goldshteyn, V.Y. Belyankov // Russian Journal of Nondestructive Testing. — 2017. — Vol. 53. — No. 8. — P. 588–595.

А.Е. Гольдштейн, Х.Х. Абакумов

Бақыланатын параметр мен саңылау мәндерінің елеулі өзгерістерімен электр өткізгіш қабырғаның қалыңдығын бақылау үшін екіжиілікті құйындыток әдісін қолдану

Бақылау объектісінің бақыланатын және әсер ететін параметрі — құйындыток түрлендіргіші мен бақылау объектісінің беті арасындағы саңылау айтарлықтай өзгерген жағдайда жеңілбалқитын бұрғылау құбырлары қабырғасының қалыңдығын құйындытокпен бақылау есебі қарастырылған. Бұл есепті шешуде қабырға қалыңдығын өлшеу үшін төмен жиілікті кернеудің фазасына енгізілген және саңылауды өлшеуде жоғары жиілікті кернеуге енгізілген амплитудада қолданбалы құйындыток түрлендіргішін ақпараттық сигнал параметрі ретінде қолдана отырып, екіжиілікті құйындыток әдісін қолдану тиімділігі көрсетілген. Ақпараттық параметрлер мәндерінің бақыланатыны және әсер ететін параметрлерге эксперименттік түрде тәуелділігі келтірілген. Құйындытоқтың бақылау тәжірибесінде қолданылатын фазалық және амплитудалық-фазалық көппараметрлерді кедергі факторларының әсерінен ажырату әдістері талданған; бақылау объектісінің бақыланатын және басқа да әсер ететін параметрлерінің елеулі өзгерістер диапазоны жағдайында оларды реттеу тиімділігінің шектеулілігі көрсетілген. Ақпараттық параметрлер мәндерінің бақыланатын параметр мәніне кері түрлендірудің сызықтық емес функцияларындағы саңылаудың өзгеруін бақылау нәтижесіне алшақтық әсерін пайдаланудың тиімділігі бағаланды. Құйындыток түрлендіргіші сигналының ақпараттық параметрлерін таңдау критерийлері қарастырылған. Бақыланатын және әсер етуші параметрлер өзгерістерінің белгіленген диапазонында ақпараттық параметрлер мәндерін бақыланатын параметр мәніне кері түрлендірудің сызықтық емес функцияларының жуықтау қателігінен туындаған өлшеу қателігінің құрамдас бөлігін бағалау жүргізілді.

Кілт сөздер: қалыңдығын өлшеу, қолданбалы құйынды ток түрлендіргіші, сигнал годографтары, кедергі параметрлері, құйындытоқты бақылау кезінде реттеу.

А.Е. Гольдштейн, Х.Х. Абакумов

Использование двухчастотного вихретокового метода контроля толщины электропроводящей стенки при значительных изменениях значений контролируемого параметра и зазора

Рассмотрена задача вихретокового контроля толщины стенки легкосплавных бурильных труб в условиях значительных изменений как контролируемого, так и влияющего параметра объекта контроля — зазора между вихретоковым преобразователем и поверхностью объекта контроля. Показана эффективность применения для решения данной задачи двухчастотного вихретокового метода с использованием в качестве информативных параметров сигнала накладного вихретокового преобразователя амплитуды вносимого напряжения высокой частоты для измерения зазора и фазы вносимого напряжения низкой частоты для измерения толщины стенки. Приведены полученные экспериментально зависимости значений информативных параметров от контролируемого и влияющего параметров. Проанализированы применяемые в практике вихретокового контроля фазовый и амплитудно-фазовый многопараметровые способы отстройки от влияния мешающих факторов; показана ограниченность эффективности их применения в случае значительных диапазонов изменений контролируемого и других влияющих параметров объекта контроля. Оценена эффективность использования для отстройки от влияния на результаты контроля изменений зазора нелинейных функций обратного преобразования значений информативных параметров в значение контролируемого параметра. Рассмотрены критерии выбора информативных параметров сигнала вихретокового преобразователя. Осуществлена оценка составляющей погрешности измерения, обусловленной погрешностью аппроксимации нелинейных функций обратного преобразования значений информативных параметров в значение контролируемого параметра в установленных диапазонах изменений контролируемого и влияющего параметров.

Ключевые слова: измерение толщины, накладной вихретоковый преобразователь, годографы сигнала, мешающие параметры, отстройка при вихретоковом контроле.

References

- 1 Klyuev, V.V. (Ed.). (2003). *Nerazrushaiushchii kontrol. Spravochnik : [V 2-kh knigakh]/ Kniga 1. Kontrol germetichnosti. Kniga 2. Vikhretokovyi kontrol [Non-destructive Testing. Handbook. Tightness testing, 1. Eddy current testing, 2. (Vols 1–7; Vol. 2)]*. Moscow: Mashinostroenie [in Russian].
- 2 Shubochkin, A.E. (2014). *Razvitie i sovremennoe sostoianie vikhretokovogo metoda nerazrushaiushchego kontrolya [Development and current status of non-destructive testing]*. Moscow: Spektr [in Russian].
- 3 Xuefei, M., & Yinzhao, L. (2013). Analytical solutions to eddy current field excited by a probe coil near a conductive pipe. *NDT&E International*, 54, 69–74.
- 4 Aikeyeva, A.A., Zhautikov, B.A., Aidarkhanov, A.M., Zhanasbayeva, A.S., Zhautikov, F.B., & Belgibayev, A. S. (2014). Modeling electromagnetic systems. *Bulletin of the university of Karaganda-Physics*, 3, 75, 28–34.
- 5 Syasko, V.A., Chertov, D.N., & Ivkin, A.E. (2011). Izmerenie tolshchiny stenok iz uglerodnykh kompozitsionnykh materialov s ispolzovaniem vikhretokovogo fazovogo metoda [Measurement of the wall thickness of products made of carbon composite materials using the eddy current phase method]. *Russian Journal of Nondestructive Testing*, 8, 76–84 [in Russian].
- 6 Syasko, V.A., & Ivkin, A.E. (2012). Izmerenie tolshchiny pokrytii iz dragotsennykh metallov s ispolzovaniem vikhretokovogo vida kontrolya [Measurement of the thickness of coatings made of precious metals by the eddy current method]. *V mire nerazrushaiushchego kontrolya — In the World of Nondestructive Testing*, 2, 56, 22–25 [in Russian].
- 7 Atavin, V.G., Uzkikh, A.A., & Iskhuzhin, R.R. (2018). Otstroika ot elektroprovodnosti pri izmerenii tolshchiny tokoprovodiashchikh pokrytii metodom vikhrelykh tokov [Detuning from the electrical conductivity of the base when measuring the thickness of conductive coatings by the eddy current method]. *Russian Journal of Nondestructive Testing*, 1, 58–64 [in Russian].
- 8 Teterko, A.Ya., Gutnik, V.I., Lutsenko, G.G., & Teterko, A.A. (2014). Metod mnogoparametrovykh vikhretokovykh izmerenii tolshchiny, elektroprovodnosti materiala i tolshchiny dielektricheskogo pokrytiia elementov konstruksii [Method of multiparameter eddy current measurements of the thickness, electrical conductivity of the material and the thickness of the dielectric coating of structural elements]. *Russian Journal of Nondestructive Testing*, 3, 55–60 [in Russian].
- 9 Egorov, A.V., & Polyakov, V.V. (2018). Vikhretokovyi kontrol metallicheskih materialov s pomoshchiu proektsionnykh metodov mnogomernogo analiza dannykh [Eddy current testing of metallic materials using projection methods of multidimensional data analysis]. *Russian Journal of Nondestructive Testing*, 5, 55–62 [in Russian].
- 10 Bakunov, A.S., & Kaloshin, V.A. (2016). Razvitie vikhretokovoi tolshchinometrii zashchitnykh pokrytii [Development of eddy current thickness measurement of protective coatings]. *Russian Journal of Nondestructive Testing*, 1, 27–31 [in Russian].
- 11 Fedosenko, Yu.K. (1981). Osnovy nelineinoi teorii vikhretokovogo kontrolya metallicheskih obektov [Fundamentals of the nonlinear theory of multiparameter eddy current testing of metal objects]. *Russian Journal of Nondestructive Testing*, 6, 38–45 [in Russian].
- 12 Goldshteyn, A.E. (2017). An eddy-current gauge for measuring the wall thickness of light-alloy drill pipes. *Russian Journal of Nondestructive Testing*, 53, 8, 588–595.