

UDC 531.751.3:621.3.083.92

**PRINCIPLES OF INFORMATION TECHNOLOGY MEASUREMENT SYSTEM  
BASED ON MODERN WEIGHTY MEASURING COMPLEX**

V.A.Kolesnikov, Ya.Zh.Baisagov

Karaganda State University named after E.A. Buketov, Universitetskaya Str.28, Karaganda, 100026, Kazakhstan  
kolesnikov.vladimir@gmail.com

*Article deals with the basic principles of building information-measuring system based on the weight of the complex. Are given the comparative characteristics of weights and weight complexes. Describes the requirements for power transmission devices. We describe development of a new set of weighing and information system. Illustrates a block diagram of the system. Are given the algorithms and three-dimensional models of system components.*

*Keywords:* information-measuring system, scales, weight complex, algorithm, three-dimensional model, dynamic weighing.

Currently in development, research and application of systems for measuring the weight of the material and its dosing has been a lot of design, engineering and industrial organizations [1, 2]. However, the necessary theory and techniques of engineering calculations insufficiently developed, and the fragmentation of information complicates the choice of optimal solutions.

Stationary weighing materials reached considerable accuracy and hardware implementation, while the dynamic weighing is still far from perfection. The reason for the latter is a large number of factors influencing a greater or lesser extent on the results of measurements in dynamic weighing. Dynamic weighing is most often used when moving material on the conveyors. Currently available in the scales of various modifications, such as VL, LTM, etc. These scales are designed for continuous weighing of bulk materials transported on the stationary conveyor belts. Such weight gauges have some significant drawbacks, in own who-lever-weight mechanical systems. They are sensitive to shock and overload, pollution prisms, pillows, racks, gears and other parts, that measure and transmit movement to the drive lever systems. This also applies to the balance spring measuring unit. If the weight of such systems are used is under the weight portion host load tape roller, then move it affects the accuracy of dosing.

Should be considered more sophisticated weight gauges whose weighty-hand platform or roller bearing is fixedly mounted, and the weight is perceived tough weight sensor.

Conveyor scales are developed and produced by virtually all industrialized countries. One of the world leaders in the design of conveyor scales considered company «Control systems technology» (Australia). Belt scales feature of this company is the ability to use them in the most extreme conditions due shockproof design platform and use of modern electronics. Large volume of work in the field of continuous conveyor weighing of bulk materials is carried out by «Thermo Scientific». List of such companies can continue.

Device transmitting force designed to: ensure uniform distribution of the load between the strain gauge force transducer is based on weighbridges; provide axial load applied to the strain gauge force sensors for deviations load-bearing devices, reducing the impact on the force sensors shear forces and moments resulting from deformation load-bearing devices or change the position of the load to be weighed; reduce impact shock loads.

Simply increasing the weight of roller to two can increase only the length of the weight portion, does not lead to a radical improvement in the accuracy, and provides some reduction in error when changing the belt tension.

Application on the same weight roller bearing, rather than two single sensor weight very efficiently. This is due to the fact that both counter-weight roller carriage mounted on the platforms

from the suspension arm by elastic hinges for the realization of the mechanical balancing, "container", and each platform rests on one weight sensor positioned relative to the second sensor platform on the opposite side of the belt, which allows to achieve one same effect of minimizing error in the "gathering" or asymmetric loading across the width of the tape as Idler KB MILLTRONICS, RAUTE, VKR, VNK, etc.

Moreover, this is achieved, according to the theory of mechanisms and machines, static structure definition, because number of support points of each platform shall not exceed three (two elastic hinge and a weight sensor). Most domestic and foreign conveyor scales, with all accuracy class recording equipment does not provide the stated accuracy. This is due, mainly the inability of many factors, such as, for example, the geometry of the conveyor, humidity and lumpiness shipping, tape quality, variable force of friction rollers in the bearings and their heartbeats, and many others.

When designing conveyor scales ignores the fact that they, like most real measurement systems represent a complex system. Hence the need for systemic and structural analysis of this kind of measurement systems, taking into account the thermodynamic constraints that are not only fundamental but also of practical importance in today's information-measuring systems.

Technological rules is the main technical document that determines the optimal process conditions, the order of operations carried on process, providing release of products of the required quality, safe operating conditions of production, and that the requirements for environmental protection. Technological rules should be developed for the process of production of certain types of products (or intermediates) of the specified quality.

Figure 1 shows the design of the adjustable efforts we developed the device transmitting power mechanical conveyor scales.

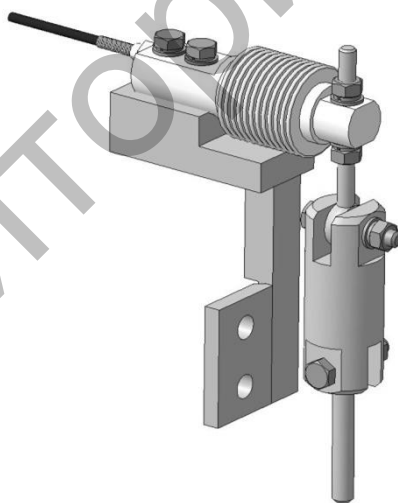

Fig. 1. Converter efforts with mounted load cell

In the system of universal transmitter is given two roles: first and foremost - is the transfer of information signal, as well as all the technological and tuning parameters of analog-to-digital converter ADC to the display and microprocessor control - Blick-M. The second function - is communication with a wireless remote control, used to configure and monitor and adjust conveyor scales.

Universal transmitter block diagram is presented in the figure 2.

Figure 2 shows that the universal transmitter module consists of a transmitter communication with the processor, will be carried out constructively in an isolated PCB-based microcontroller. The module performs integrity monitoring software to receive and impart information. Module

associated with adjacent modules physical transmission protocol information RS-485 and over the air to a distance of several meters. In a transmitter also include Wi-Fi antenna.

ADC block with universal analog-to-digital converter is the heart of information-measuring system weighing bulk materials. This is an analog to digital converter performs the primary trained analog signal proportional to the weight of the material on the scales of its digitization and subsequent processing and storage. ADC is designed as a double-sided PCB segregated with various integrated modules based on modern microprocessor STM32F103RBT6. Universal analog-to-digital converter is also built on the principle of modularity. Block diagram of the analog-to-digital converter is shown in Figure 3.

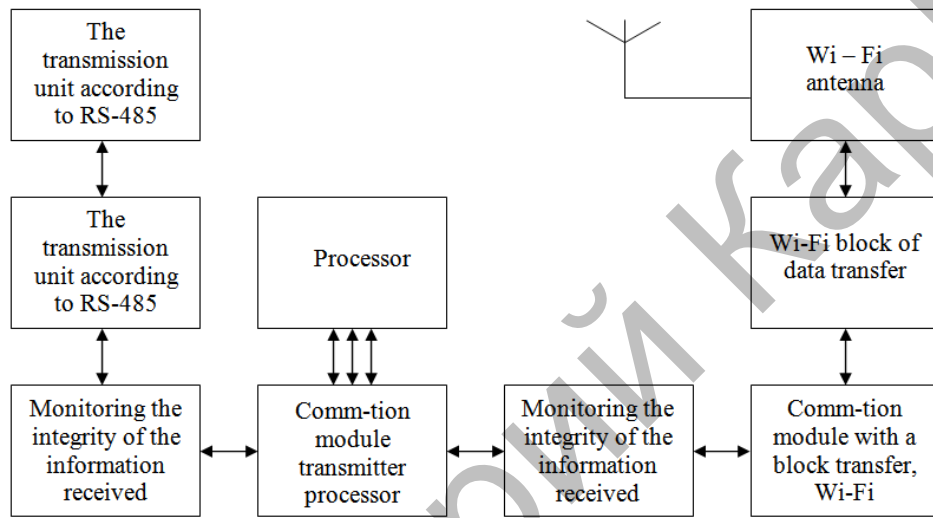

Fig.2. Block diagram of a universal transmitter

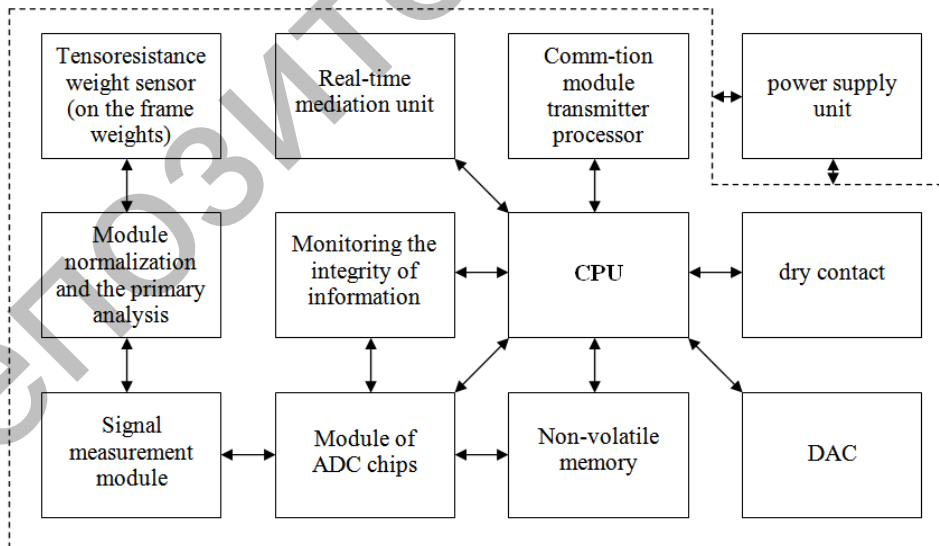

Fig.3. Block diagram of a universal analog-to-digital converter

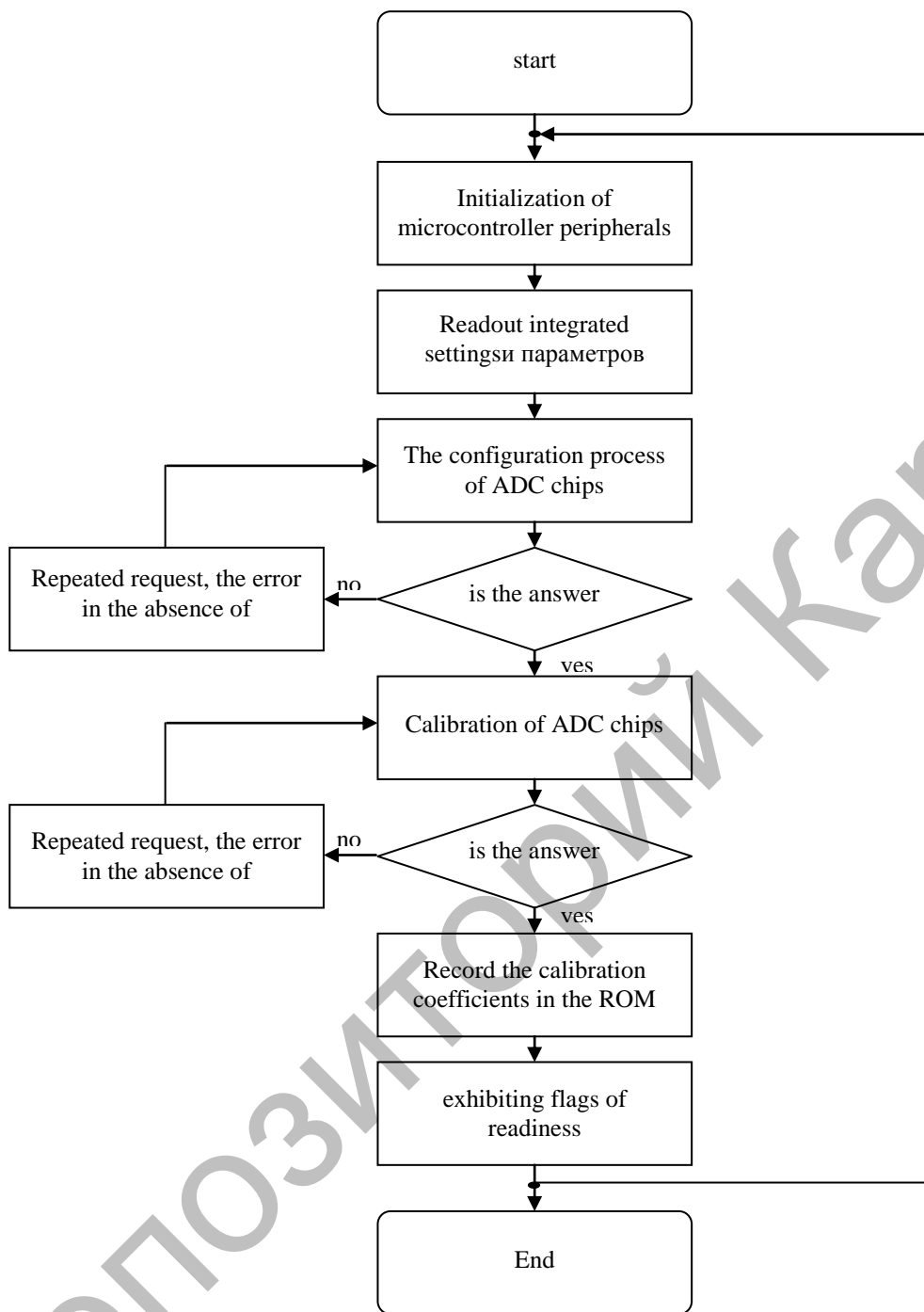

Fig.4. Flowchart peripheral initialization and ADC

As seen from the figure versatile analog-digital converter consists of a large number of modules. Analog-to-digital converter is a complex multi-module system with firmware in the microcontroller that performs the basic functions of information-measuring system weighing bulk materials.

Power supply is structurally made on a separate PCB and will provide the entire range of voltages the ADC system.

Flowchart peripheral initialization and ADC chips of microcontroller is shown in Figure 4.

As seen in Figure 4, when power comes initialization microcontroller ports and reading settings from nonvolatile memory and then initialization process ADC chips. If there is a response from the chip and the connection works fine, starts the process of setting ADC chips. In the absence of a response from the ADC chips occurs retry initialization if still no response, and exhibited an error message is sent to the ADC. Thereafter, the self-calibration process is started ADC chips, according to the same algorithm as in the initialization. Upon successful calibration coefficients stored in nonvolatile memory and ADC flag is ready to work.

## REFERENCES

1. Lotkov N.A., Polukhin A.I., Tantlevskiy A.V., Chernykh V.D. Storage Equipment Handbook. - M. Agropromizdat, 1989. – 240 p.
2. Katryuk I.S. Machines of the continuous transport. Construction, design and operation. - Krasnoyarsk: CPI KSTU 2006. - 266 p.

Article accepted for publication 29.11.2013