

Zh.S.Bekturhanov<sup>1</sup>, S.V.Kussaikin<sup>2</sup>

<sup>1</sup>Regional directorate of broadcasting, Karaganda;  
<sup>2</sup>Siberian State Aerospace University, Krasnoyarsk, Russia  
(E-mail: [semyon.kussaikin@gmail.com](mailto:semyon.kussaikin@gmail.com))

### **Automatic current-voltage characteristic measurement using transistors as variable load**

The article describes a method for measuring current-voltage characteristics using transistors as a variable load. Suggested system is part of an automated quality control complex for space applications solar panels. As a part of the description of the system its integral parts are described, both hardware and software. Several examples of calculations and measurements using this system are presented. In conclusion, an opinion on the functionality and performance of the system is provided.

*Key words:* current-voltage characteristics, energy generators, solar cells, transistors.

The power supply system of the spacecraft is one of the most important systems. Due to this system the rest of the systems can operate — from the payload to the onboard computer, the active temperature control system, a system of correction and orientation. There are many different methods of producing energy. As for the spacecrafts as the primary source currently following energy generators are used:

- solar panels;
- chemical sources of electricity, in particular:
  - batteries,
  - galvanic cells,
  - fuel cells;
- radioisotope power sources;
- nuclear reactors.

However the most widely used and the most reliable source of energy is currently solar power. Since most of the communication, earth observation and navigation satellites use solar energy as a primary source this method of obtaining energy will remain a priority for a long period of time [1].

Currently classification of photovoltaic cells can be classified into four generations, which includes the following.

First generation of photovoltaic cells: cells based on the slabs of crystal silicon. Usually, its cells of clean single and poly crystal silicon with thickness around 200–300 micrometers. This group also includes GaAs photovoltaic cells and ribbon-technology cells. They have high efficiency (17–22 %) and high cost. Currently this type of cells occupy 82 % of market share.

Second generation cells are based on the usage of thin films, while crystalline silicon is not used as a main material. Usually following materials are used: tellurium, cadmium (CdTe), a mixture of copper, indium, gallium and selenium (CIGS) and amorphous silicon. Usually thickness of the absorbing layer of a semiconductor is around 1 to 3 micrometers. These cells have average cost and efficiency from 7 to 15 %. Currently they occupy 18 % of market share.

Third generation of photovoltaic cells is also related to thin film technology, but they, however, do not have p-n junction, therefore do not have semiconductors either. This technology ensures low cost but also low efficiency, which does not exceed 7 %. Currently market share of the third generation cells does not exceed 0.5 % [2].

Due to the high importance of power supply system for the sustainability of the spacecraft a number of different tests and checks are performed to ensure, the smooth operation of the system with high efficiency. These checks usually very lengthy in terms of time and require participation of a large number of highly qualified specialists. One way to speed up the process and reduce the cost of the test works is the use of automated quality control system for solar panels.

According to the European standard regarding space equipment — ECSS-E-ST-20-08C two most frequent inspections are visual inspection and tests to confirm the energy characteristics. This article will consider the automation of the process of testing to confirm the energy characteristics [3].

Testing on definition (confirmation) of energy characteristics of solar cells can be done in a number of various ways. Although the accuracy of measurements, time of the tests as well as other parameters may differ for different types of solar cells, there is a basic set of parameters that are always determined during the testing of a solar cell:

Open-circuit voltage ( $V_{oc}$ ) — The cell voltage at which point there is zero current flow.

Short-circuit current ( $I_{sc}$ ) — The current flowing out of the cell when the load resistance is zero.

Maximum power output of the cell ( $P_{max}$ ) — The voltage and current point where the cell is generating its maximum power.

Voltage at  $P_{max}$  ( $V_{max}$ ) — The cell's voltage level at  $P_{max}$ .

Current at  $P_{max}$  ( $I_{max}$ ) — The cell's current level at  $P_{max}$ .

Conversion efficiency of the device ( $\eta$ ) — The percentage of power converted (from absorbed light to electrical energy) and collected when a solar cell is connected to an electrical circuit. This term is calculated using the ratio of the maximum power point,  $P_{max}$ , divided by the input light irradiance ( $E$ , in W/m<sup>2</sup>) under standard test conditions (STC) and the surface area of the solar cell ( $A_c$  in m<sup>2</sup>).

Fill factor ( $FF$ ) — The ratio of the maximum power point,  $P_{max}$ , divided by the open circuit voltage ( $V_{oc}$ ) and the short circuit current ( $I_{sc}$ ) [4].

Most often tests to obtain a light CVC are conducted; however, if access to the panels is difficult, and as a result, there is no way to use solar simulator, the test is carried out to obtain the dark current-voltage characteristics.

**Light CVC.** The solar cell is lit upon by the solar simulator and by changing the load resistance from 0 to  $\infty$ , current-voltage characteristics is obtained. The current-voltage characteristic, assuming that the shunt resistance is insignificant, can be described by the following expression [5]:

There are several ways to determine the current-voltage characteristics of a solar cell/panel. Device for measuring CVC is aimed to determine the ability of the panel to generate the required amount of power at a given luminous flux density and temperature. Apparatus for measuring the current-voltage characteristics includes instruments for measuring volt-meter and ampere-meter that are connected to the variable load. The equivalent circuit of this setup is shown in Figure 1.

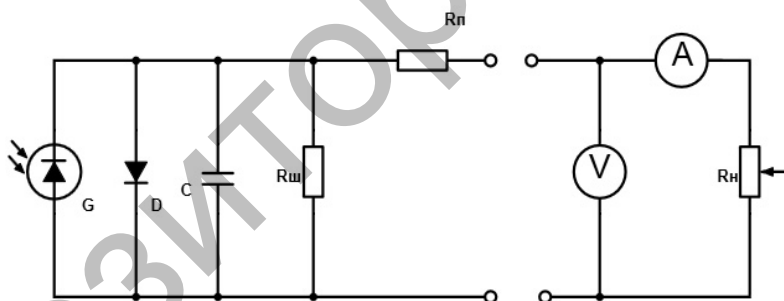

$G$  — DC generator;  $D$  — diode operating in the mode of direct bi as accounts for properties of the p-n-junction;  $C$  — junction capacitance;  $R_n$  — series resistance;  $R_{ш}$  — shunt resistance;  $R_H$  — variable resistance load

Figure 1. The equivalent circuit diagram of the solar cell (left) and the measuring circuit (right)

Measurement of the CVC is done as follows: the resistance value is set to zero, thus, the cell voltage is also small, and the current flowing in the circuit can be considered as the maximum (short circuit current). When the load is changed both the cell voltage and the current are changing. When the load resistance high enough to assume that  $R_H \rightarrow \infty$  the current through the element will be zero and the maximum voltage on the element will be achieved (open circuit voltage).

The accuracy of measurement results may be affected by the radiation flux ripple, which is inherent characteristic of the xenon lamps operating on AC or not smoothed DC. Additionally high impedance of the device when measuring the short-circuit current may add to the error, in turn, open-circuit voltage measurement requires a high impedance voltmeter [6].

Thus the main task in the automation of work on the measuring of the CVC is the automation of the change in resistance and recording of the measurements with plotting of a CVC graph.

As indicated above, the purpose of the variable load is the current and voltage change in the circuit due to resistance change. The task of changing the current and voltage in the circuit can be handled by a transis-

tor; therefore, for the purposes of automating load changes the use of a transistor is proposed with a supply voltage fed to the base and connecting the emitter to the «earth» (common ground, sink). The scheme is shown below (Fig. 2).

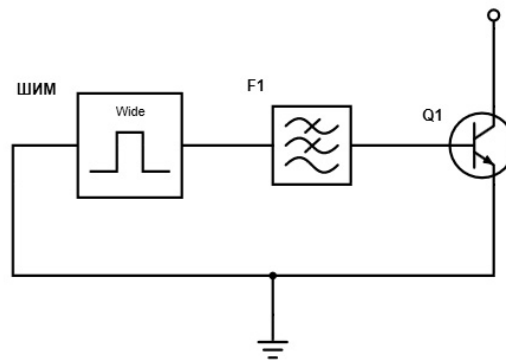

Figure 2. Electric circuit with the replacement of variable resistance load by transistor

Voltage is applied to the base as the rectified and amplified PWM. Data is received by analog inputs in the form of voltage levels.

Transistors can be classified with respect to the following traits:

- By the semiconductor material — usually silicon or germanium;
- Conductivity type regions forward conductive (*p-n-p*-structure) or reverse conductive (*n-p-n* — structure);
- Principle of the operation — bipolar and field (unipolar);
- Frequency characteristics — low frequency (<3 MHz), medium (3 to 30 MHz) and high (> 30 MHz);
- Power — low power (<0.3 watt), average power (from 0.3 to 1.5 W) and high power (> 1.5 W).

For the purpose of the device high power, low frequency, bipolar transistor is needed, conductivity type and material are irrelevant in the scope of this article. High power transistors are usually low frequency, and since frequency of the pulse as it will be stated later in the article is 500 Hz which is obviously less than 3MHz low frequency transistor would suffice. Bipolar transistor is needed because it is controlled by voltage and can be controlled with PWM after filtering without need to add additional devices to convert voltage control to current control as would be the case with a unipolar transistor [6].

When measuring the performance of the Solar Battery with usage of a transistor, it is important to choose it so that it would withstand the current and voltage passing through it. Additionally, resistance of the transistor must be small enough to be able to provide opportunity to measure low current and voltage.

Given the basic characteristics of platforms for telecommunication satellites, for example, «Express-1000» and «Express-2000» that can be derived from the presentation of «prospects for improving the efficiency of communications satellites created on the basis of platforms families» Express-1000H» and «Express-2000», it can be concluded that the power of one panel is 1500W, and therefore the short circuit current is around 40A [7].

There are transistors on the market that allow to work with high currents and power. Such as transistor MJ11032 has the ability to withstand a current up to 50A, voltage up to 120V and to dissipate up to 300W of heat without a heat sink at 25 °C. Nonetheless, using high power transistors may lead to the following problems: the channel resistance in the open state, and the ability to dissipate sufficient heat under the load. The first problem imposes a limit on the accuracy of measurement of short circuit current at which the resistance should be minimal, and the second to the possibility of non-destructive measurement with the transistor usage.

Both of these problems can be solved by including a group of transistors in parallel as shown in Figure 3, additionally, transistors can be equipped with radiators for more effective cooling. Possibility of parallel connection of transistors not only solves the problems mentioned above, but also allows to adapt steps of the measurements for more accurate measurements to obtain a larger number of points in the region of interest for CVC.

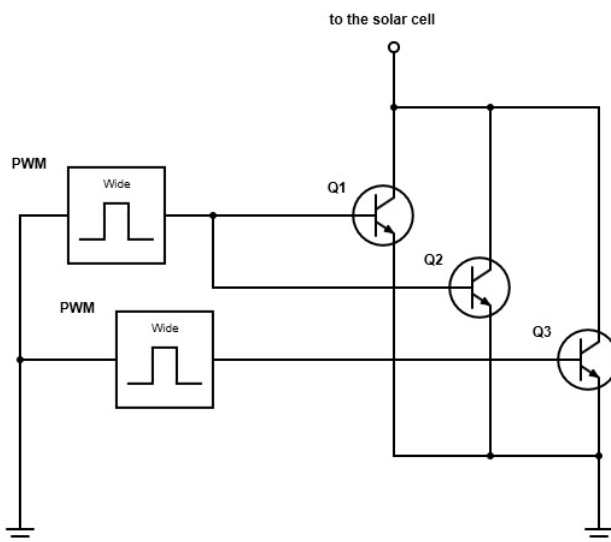

Figure 3. Parallel connection of transistors with separate PWM control

For acquiring measurement data it is proposed to use Arduino microcontroller based on the chip ATmega168 for the functional model. While for the final system that will be applied using Programmable Logic Device is suggested. Data from analog inputs of the Arduino is received and then transferred to a computer for further processing through the serial port. Where graphs are plotted and needed calculations are performed in order to determine required parameters.

To determine the voltage in the circuit with one or a group of photo voltaic cells the use of amplifiers may be needed in order to increase or decrease voltage to be able to read in the value, depending on the desired measuring sensitivity.

In order to verify the logic and the operation of the device, functional model was assembled for measuring of the CVC of a group of solar elements. Arduino microcontroller enables output of the PWM signal from 0 to 5V, with a step change in the signal is equal to  $1/255$ , from which it can be concluded that a step change in voltage is equal to 0.02V, this step is sufficient to measure CVC of one or a small group of elements. When building a system to test panels, all will depend on the capabilities of the controller clock, but using multiple transistors, together with the power amplifiers provides opportunity to increase or decrease the step up to the required values [8].

The PWM has to be «straightened» and it is desirable to smooth signal as much as possible in the shortest time. According to the patent RU2388104 voltage pulse generator for the solar imitator lamp is based on a large number of series-connected LC-chains, allowing the formation of a light pulse with a flat top duration from 4 to 100 milliseconds. (See. US Patent No.7,411,408, IPCG01R 31/302, publ.12.08.2008). Consequently the filter should provide a settling time of 2 milliseconds maximum. This limitation applies only to pulse light sources, and taking into account the fact that the device can be set to the needed value of impedance prior to flash, and switching can occur smoothly, in order to improve the quality of the signal for better measurements, settling time for the filter can be increased [9].

Arduino provides PWM with a frequency of 500Hz, the timer has 255 steps and can support up to 16 bit values. But given that the standard settings step –1 to 225, we can conclude that the timer is 8 bit.

There are many ways to create low-pass filter; one of the simplest is the LC-filter, besides there is an opportunity to improve the characteristics of the filter by stacking filters and forming a chain of filters. These filters are stable, and for purposes of the device may provide sufficient signal quality and performance. The goal when creating a filter to get the PWM smoothing in which the ripple factor is less than half of the smallest measured value.

Ripple factor can be calculated using the following formula [10].

Based on the assumption that the cut-off frequency of the filter is 10 times less then switching frequency the ripple factor can be calculated using the following formula:

Setting the ripple to be equal to the minimal ripple we can rearrange and calculate the needed order of the low pass filter

$$order = (n + 1) \cdot \log(2) = (8 + 1) \cdot \log 2 = 2,7 = 3 .$$

Therefore to achieve the desired result, the filter must be of the third order. Calculate the filter of the first order, given the fact that each successive stage of the filter should not load the previous one, as a result, capacitance will have to be reduced, for the first stage; we will take a value of  $10 \mu\text{F}$  Calculating the resistance from the cutoff frequency.

For the first order  $RC$ , filter cutoff frequency can be described as following:

$$f_c = \frac{1}{2\pi RC}.$$

Deriving resistance from this equation:

$$R_1 = 320\Omega.$$

Changing capacitance for each subsequent stage by the factor of 10 we get:

$$R_2 = 3.2 \text{ K}\Omega, C_2 = 1 \mu\text{F}; R_3 = 32 \text{ K}\Omega, C_3 = 1 \text{ nF}.$$

The electrical diagram of the device is shown below:

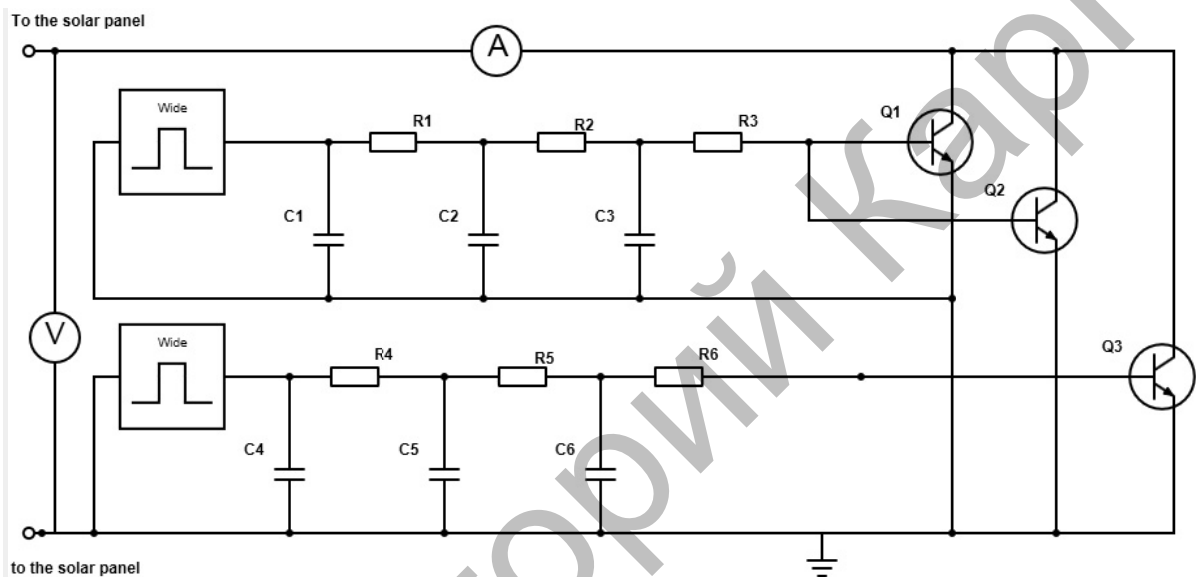

Figure 4. General circuit diagram using transistors

As can be seen from the diagram shown in Figure 4 it is possible to connect several transistors, thereby changing the measuring step, which allows to use the system for accurate measurement of low-power characteristics of solar cells and to measure the characteristics of panels and solar panels as a whole where high power throughput is required.

By measuring CVC using of the solar element and comparing it with the measurements of CVC provided by the plant it can be stated that the measurements are somewhat accurate, not taking into consideration temperature variations and light source quality (Fig. 5).

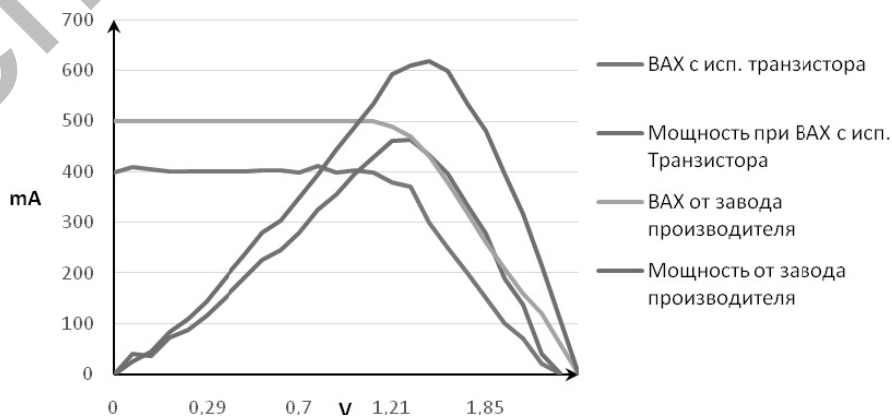

Figure 5. Current-voltage characteristics of a test solar cell

Therefore, device can be used to determine the current-voltage characteristics of solar panels as an alternative to the existing devices. The advantages of this device are simplicity, low cost, high speed measurements, ability to integrate with other systems and the possibility to adapt this unit for systems with different levels of performance, without losing accuracy of the measurements.

### References

- 1 Гущин В.Н. Системы энергопитания. Основы устройства космических аппаратов: Учебник для вузов. — М.: Машиностроение, 2003. — С. 217–241.
- 2 Solar element development. (23 November 2012). Retrived on 20.01.2014 y. // [ER] Solarsoul.net. Access mode: <http://solarsoul.net/razvitie-fotoelementov>
- 3 European Cooperation for Space Standardization. Space engineering. Photovoltaic assemblies and components. ECSS-E-ST-20-08C — 18 July 2012 — Revision 1. — P. 2, 7.
- 4 Agilent Technologies. Solar Cell and Module Testing. How to decrease costs and increase flexibility in a rapidly changing test environment. Agilent Technologies, Inc. — Printed in USA, 2009. — P. 2, 7.
- 5 Раушенбах Г. Справочник по проектированию солнечных батарей. — М.: Энергоатомиздат, 1983. — С. 15, 231, 238.
- 6 Биполярные транзисторы. Классификация и маркировка транзисторов: Курс лекций Дальневосточного ун-та путей и сообщений // [ЭР]. Режим доступа: [http://edu.dvgups.ru/METDOC/ENF/OP\\_KV\\_EL/OSN\\_SHEMOTEN/METHOD/BODROV\\_UP/WEBUMK/frame/1.htm](http://edu.dvgups.ru/METDOC/ENF/OP_KV_EL/OSN_SHEMOTEN/METHOD/BODROV_UP/WEBUMK/frame/1.htm)
- 7 Тестоведов Н. Перспективы повышения эффективности спутников связи, создаваемых на базе платформ семейств «Экспресс-1000Н» и «Экспресс-2000» ОАО «ИСС» им. акад. М.Ф. Решетнева. — 30 окт. 2012. — С. 6, 8, 10, 12–14.
- 8 Shirriff K. Secrets of Arduino PWM. November 2009. [ER]. Access mode: <http://www.righto.com/2009/07/secrets-of-arduino-pwm.html>
- 9 Андреев В.М., Давыдок Н.Ю., Ларионов В.Р. и др. Пульсовый симулятор солнечного излучения. Патент RU2388104. — Янв. 2006.
- 10 Art Kay, Andrew Wu. TI Precision Designs: Verified Design Microcontroller PWM to 12bit Analog Out // TexasInstruments. — 2013. — P. 8–11.

Ж.С.Бектурганов, С.В.Кусайкин

### **Айнымалы жүктемелер ретінде транзисторларды қолдануы арқылы вольтамперлік сипаттаманы автоматты түрде өлшеу**

Мақалада айнымалы жүктеме ретінде транзисторлардың көмегімен вольтамперлік сипаттаманы өлшеу әдісі қарастырылған. Ұсынылған жүйе ғарыш техникасы үшін күншуақты батарея панельдерінің сапасын бағалауға арналған автоматты кешеннің бір бөлігі болып табылады. Бұл жүйені сипаттауда аппаратты және бағдарламалық интегралды бөліктерінде зерттелген. Сондай-ақ есеп мысалдары мен зерттеу нәтижелері келтірілген. Осы жүйенің қызметі және жұмыс қабілеті жайлы қорытынды жасалған.

Ж.С.Бектурганов, С.В.Кусайкин

### **Автоматическое измерение вольтамперной характеристики с использованием транзисторов в качестве переменной нагрузки**

В статье рассматривается способ измерения вольтамперной характеристики с использованием транзисторов в качестве переменной нагрузки. Предлагаемая система является частью автоматизированного комплекса проверки качества панелей солнечных батарей для космической техники. В рамках описания системы рассматриваются ее интегральные части, как аппаратные так и программные. Приводятся примеры расчетов и результаты измерений с использованием данной системы. В заключение делается вывод о функциональности и работоспособности системы.

### References

- 1 Gushchin V.N. Power supply systems. Basics of spacecraft organization: Textbook for universities, Moscow: Mashinostroeniye, 2003, p. 217–241.
- 2 Solarsoul.net: <http://solarsoul.net/razvitie-fotoelementov>.

- 3 European Cooperation for Space Standardization. *Space engineering. Photovoltaic assemblies and components*. ECSS-E-ST-20-08C, 18 July 2012, Revision 1, p. 62.
- 4 Agilent Technologies. *Solar Cell and Module Testing. How to decrease costs and increase flexibility in a rapidly changing test environment*, Agilent Technologies, Inc., Printed in USA, 7 Dec. 2009, p. 2, 7.
- 5 Raushenbah G. *A guide to the design of solar panels*, Moscow: Energoatomizdat, 1983. p. 15, 231, 238.
- 6 *The bipolar transistors. Classification and labeling of transistors*: Lectures from Far Eastern University of transport and communications, [http://edu.dvgups.ru/METDOC/ENF/OP\\_KV\\_EL/OSN\\_SHEMOTEH/METOD/BODROV\\_UP/WEBUMK/frame/1.htm](http://edu.dvgups.ru/METDOC/ENF/OP_KV_EL/OSN_SHEMOTEH/METOD/BODROV_UP/WEBUMK/frame/1.htm)
- 7 Testoedov N. *Prospects for improving the efficiency of communications satellites created on the basis of platforms families «Express-1000H» and «Express-2000» JSC «Information Satellite Systems» Reshetnev Company*, 30 Oct. 2012, p. 6, 8, 10, 12–14.
- 8 Shirriff K. *Secrets of Arduino PWM*, Nov. 2009, <http://www.righo.com/2009/07/secrets-of-arduino-pwm.html>
- 9 Andreev V.M., Davidok N.Yu., Larionov V.R. et al. *Pulse solar radiation simulator*, RU2388104, Jan. 2006.
- 10 Art Kay, Andrew Wu. *Texas Instruments*, 2013, p. 8–11.

Репозиторий КарГУ