

UDC 621.311.21:628

EXPERIMENTAL STUDIES OF THE VORTEX HYDRAULIC ELEVATOR**Sakipov K.E.¹, Abirov A.A.², Sharifov D.M.¹, Makhmudov B.N.³**¹L.N. Gumilyev Eurasian National University, Astana, Kazakhstan, kafedra_te@enu.kz²Institute of Scientific, Technical and Economic Studies, Astana, Kazakhstan³S.U. Umarov Physical and Technical Institute, Dushanbe, Republic of Tajikistan

The article presents the results of experimental studies to assess the optimal operation modes of the vortex hydraulic elevator of the autonomous water treatment system. Based on experimental studies, it has been shown that twisting of the working and suction flows significantly increases the ejection capacity of vortex hydraulic elevators. The analysis of the results obtained (the curves of the dependence of the ejection coefficient on the spin parameters) allows us to conclude that there are optimal critical values for the vortex hydraulic elevator and hydraulic elevator with a tangential intake of the intake medium at which the highest value of the ejection coefficient is reached. It was also revealed that the swirling active and passive flows radically affect the mechanism for drawing the intake fluid into the mixing chamber of the hydraulic elevator. An increase in the swirling intensity increases the mixing of the flow, and large pressure gradients occur not only in the axial but also in the radial direction, which leads to an increase in the ejection coefficient. Thus, on the basis of the conducted experimental studies and preliminary technical and economic calculations, it can be concluded that the use of vortex hydraulic elevators for hydro transportation of various mixtures will significantly reduce energy consumption and increase the efficiency of their application.

Keywords: hydraulic elevator, pump, hydraulic mixture, ejection, working nozzle, active stream, passive stream.

Introduction

Hydraulic elevators are used in various industrial sectors: mining, chemical, petroleum, food, gas, gold mining, industrial heat engineering, etc. In the system of agricultural water supply and irrigation of pastures, hydraulic elevators are used to clean mine draw-wells, wells, ponds and other irrigation sources from sediments, and also as water-lifting units for lifting and transporting of water. The widespread use of hydraulic elevators is primarily due to the fact that they are simple in construction, the cost is insignificant, and they are almost trouble-free in operation. Their dimensions are so small that they essentially do not occupy the production area i.e. do not need any premises [1-3].

However, as the practice of using hydraulic elevators shows, their effective operation depends on many factors, including how the working and suction flows are fed into the receiving chamber [4-5]. The swirling flow fundamentally affects the mechanism of fluid flow in the receiving chamber, the work process and hydraulic elevator performance, hydraulic and geometrical parameters, and is characterized by properties that differ from axial flow:

- has axial, rotational and radial velocity components;
- high level of turbulence;
- longitudinal and transverse gradients of static and total pressure;
- the emergence of centrifugal forces and its active influence on the flow, etc. [6-8]

1. Experimental part

The main objective of the research was to determine the ejection coefficient q of the intake medium during tangential flow of active and passive media into the receiving chamber of the hydraulic elevator. These studies were related to the following issues:

- determination of the optimal position of the working nozzle;
- the effect of swirling active and passive streams on the pressure head-rate characteristics of the hydraulic elevator;

Studies of the effect of swirling of active and passive media on the working process of the hydraulic elevator and comparison the obtained results with the results of studies of a direct-flow hydraulic elevator and hydraulic elevator with a tangential intake of the intake medium were carried out on an experimental setup (Fig. 1, 2).

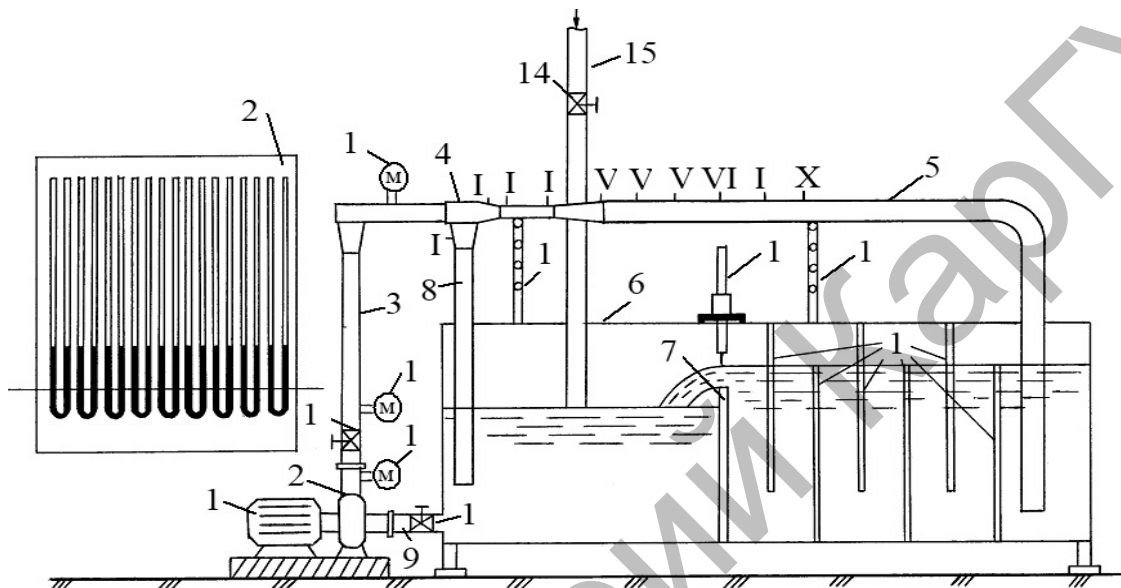

Fig.1. Experimental setup scheme

The experimental setup consists of (fig. 1,2): 1 - electric motor; 2 - centrifugal pump 3K-6; 3 - pump discharge pipe, made of flexible hose; 4 - hydraulic elevator; 5 - hydraulic elevator pressure pipe; 6 - tank with weir 7, at the same time being a reservoir for powering the suction nozzles of hydraulic elevator 8 and the pump 9; 10 - pacifiers; 11 - spitz scale to determine the water level on the weir 7 and the free surface in the tank 6; 12, 13, 14 - valves; 15 - supply pipe; 16, 17, 18 - manometers; 19 - supporting rods with crossbars; 20 - stand with piezometers. Tank 6 with weir 7 is designed to measure the water flow through the pressure pipeline 5, as well as to feed the suction nozzle of hydraulic elevator 8 and pump 9.

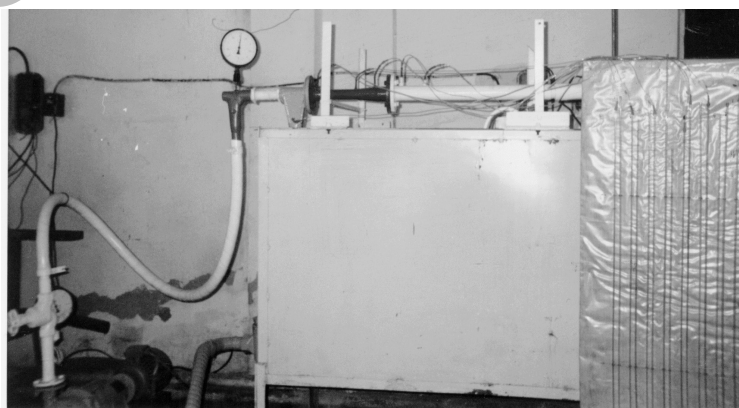

Fig.2. Experimental unit of vortex hydraulic elevator

In order to change the geometric height of the suction, the hydraulic elevator is installed on the crossbars with the possibility of vertical movement along the support pillars 18. By changing the geometric height relative to the free surface of the water, it is possible to study the designs of hydraulic elevators at different vacuum height of suction (from negative to positive). The supply pipe 15 is designed to fill the tank 6 with water and providing a certain level in it. A distinctive feature of the design of hydraulic elevators were methods of supplying of active and passive media to the receiving chamber.

In the first setup (Fig. 3), the active and passive jets are fed directly into the receiving chamber, i.e. as it is used in hydraulic elevator constructions currently used in various industries, industry and technology [1].

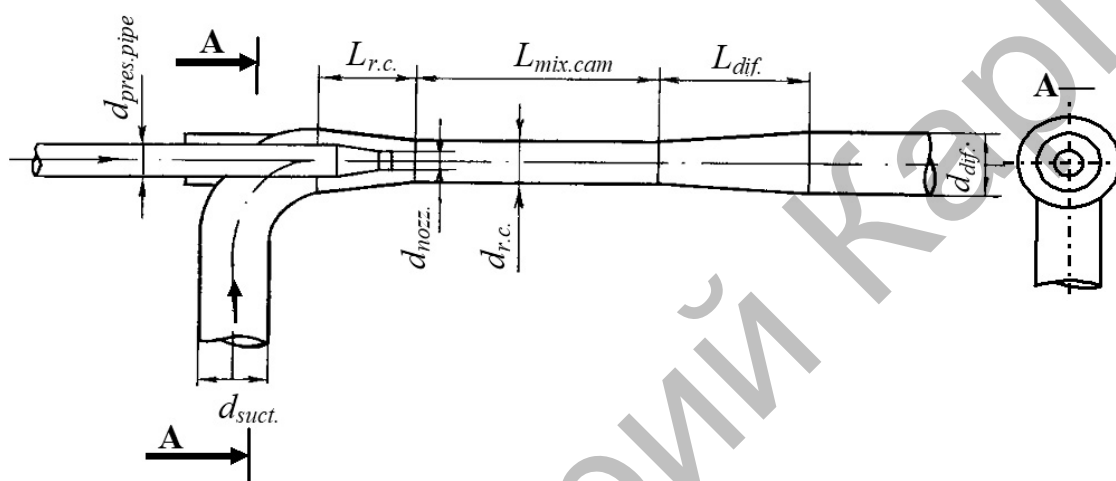

Fig.3. Scheme of direct-flow hydraulic elevator

In the second - the active jet is fed straight into the receiving chamber, passive - with a twist, thanks to a tangential feed (Fig. 4). The third design differs from the previous method of supplying the active jet. The working stream is fed into the hydraulic elevator nozzle through a tangentially cut slit of size $a_0 \times b_0 = 40 \times 17.6$ mm, the area of which is equal to the cross-sectional area of the pump discharge pipeline (Fig. 5).

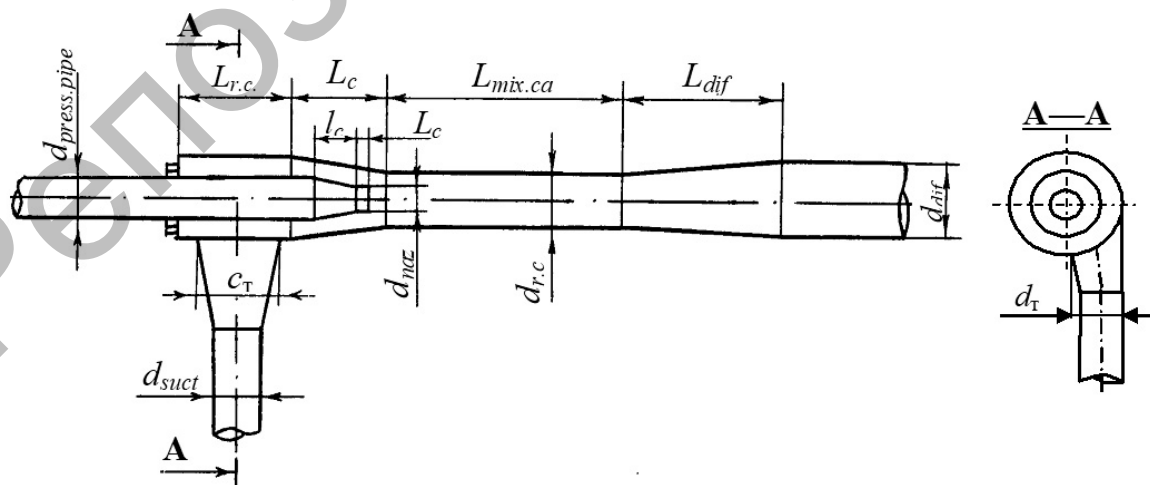

Fig.4. Diagram of a hydraulic elevator with a tangential supply of intake medium

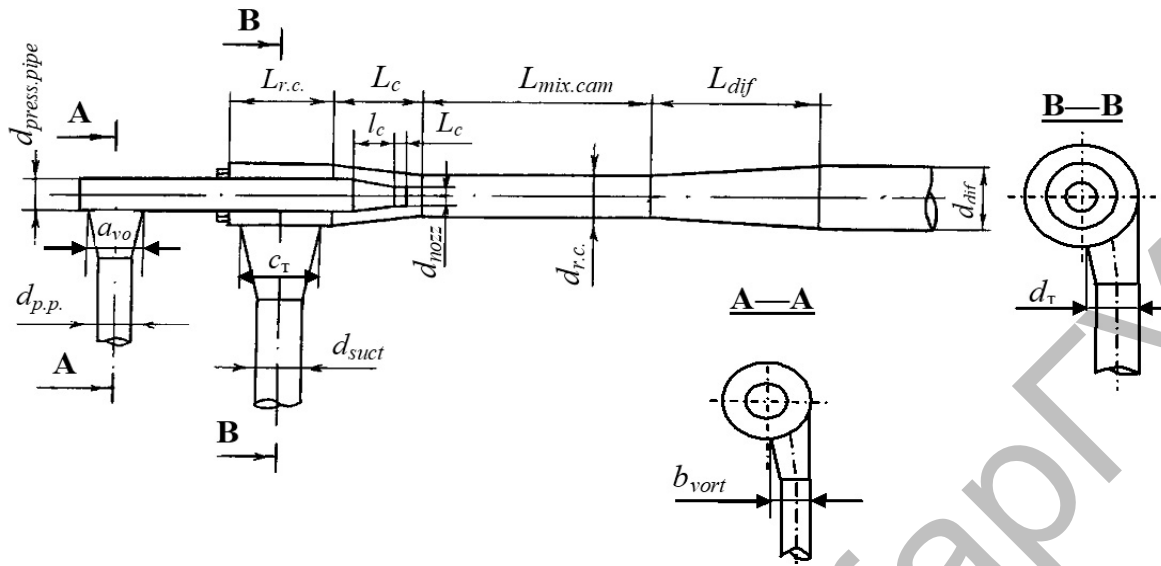

Fig.5. Diagram of the vortex hydraulic elevator

In the design of hydraulic elevators, the condition of coaxiality of structural elements is strictly maintained and made in such a way that the distance from the nozzle to the mixing chamber can be changed, which is achieved due to the fact that the section of the discharge pipe with the nozzle can be moved along the thread. Geometrical dimensions (mm) of the main structural elements of hydraulic elevators are shown in Table 1.

Table 1. Dimensions of the main structural elements of hydraulic elevators

| Type of hydraulic elevators | d_{nozz} | $d_{pres.pipe}$ | $d_{p.p.}$ | $d_{r.c.}$ | d_{suct} | $l_{confus.}$ | $L_{mix.cam}$ | $L_{dif.}$ | L_c | $L_{confus.}$ | $L_{tan r.c.}$ | $L_{vort r.c.}$ | $c_r \times d_r$ | $a_v \times b_v$ |
|---|------------|-----------------|------------|------------|------------|---------------|---------------|------------|-------|---------------|----------------|-----------------|------------------|------------------|
| Direct flow E_{direct} | 15 | 50 | - | 32 | 50 | 60 | 175 | 90 | 15 | 60 | - | - | - | - |
| With tangential fed of intake flow E_{tang} | 15 | 50 | - | 32 | 50 | 60 | 175 | 90 | 15 | 60 | 114 | - | 95x20.7 | - |
| Vortex E_{vor} | 15 | 50 | 30 | 32 | 50 | 60 | 175 | 90 | 15 | 60 | - | 114 | 95x20/7 | 40x17.6 |

The experiments were conducted with the aim of obtaining the coefficient of ejection of hydraulic elevators at different:

- pressures of the working fluid;
- the distance from the cut of the working nozzle to the beginning of the mixing chamber;
- geometric elevation of the hydraulic elevator;
- stream spin settings.

To obtain direct or swirling flows, the hydraulic elevator was made of the following separate detachable elements:

- receiving chamber with direct-flow input of the passive medium;
- receiving chamber with tangential passive medium input;
- nozzle with tangential input of the active medium.

2. Research results

Figure 6 presents the forms of jet outflows from the working nozzle: straight-flow and swirling.

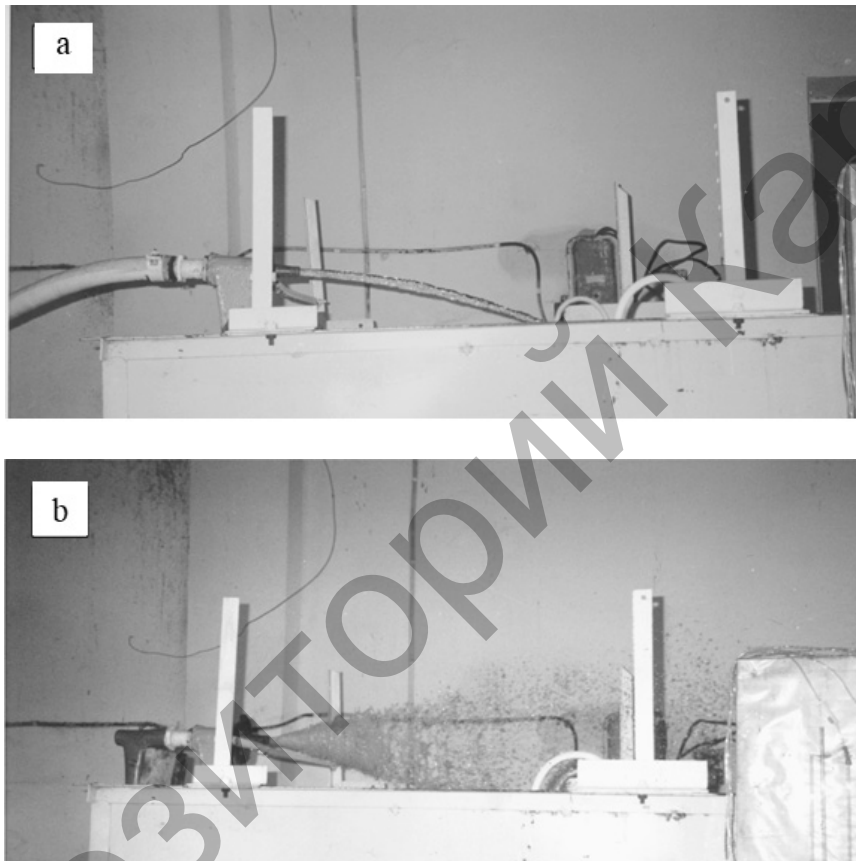

Fig.6. Active jet outflow from a working hydraulic elevator nozzle:
a) a direct flow jet; b) swirling.

In order to study the influence of the position of the working nozzle (Fig. 7) in the receiving chamber on the characteristics of the hydraulic elevator, experiments were conducted at the following distances from the nozzle section to the inlet section of the mixing chamber: $l_c = 0; 10; 20; 30; 40$ mm. During experiments the values of the coefficient of ejection q hydraulic elevators was determined. Figure 8 shows the experimental curves $l_{cr}/d_c = f(q)$.

From the graphical dependences it can be seen that the optimal distance from the nozzle to the mixing chamber is $l_c = 30$ mm, which is equal to $\frac{l_c}{d_c} = 2$ while the diameter of the mixing chamber $d_{\text{mix.cam.}} = 32$ mm and the diameter of the nozzle $d_c = 15$ mm.

According to recommendation [3], when calculating jet devices, the optimal distance from the nozzle to the mixing chamber is based on the condition that with the calculated ejection coefficient q , the area of the final section of the free jet leaving the nozzle is equal to the area of the input

section of the mixing chamber. In this case, it is necessary to calculate the length of the free jet and its diameter at a distance l_{cm} from the working nozzle section.

The value of l_{cm} is determined depending on the value of the ejection coefficient according to the following formulas :

while $q \leq 0.5$

$$l_{cm} = 3.12d_c(\sqrt{0.083 + 0.76q} - 0.29), \quad (1)$$

While $q > 0.5$

$$l_{cm} = 1.43d_c(0.37 + q). \quad (2)$$

Accordingly, the jet diameter $d_{ct.}$ at the entrance to the mixing chamber while $q \leq 0,5$

$$d_{cm} = 3.4d_c\sqrt{0.083 + 0.76q}, \quad (3)$$

while $q > 0.5$

$$d_{cm} = 1.55d_c\sqrt{1 + q}. \quad (4)$$

If, as a result of the calculation, it turns out that the jet diameter d_{cm} is less than the diameter of the mixing chamber $d_{\kappa.cm.}$, then the distance between the nozzle section and the inlet of the mixing chamber is taken to be l_{cm} . At the same time, installation of the nozzle closer than at a distance l_{cm} does not significantly affect the operation of the hydraulic elevator, since the final section of the jet fits perfectly into the mixing chamber.

Recession the nozzle from the mixing chamber can significantly impair the operation of the hydraulic elevator. In this case, the jet does not fit into the inlet section of the mixing chamber. The resulting backflow of the liquid will lead to additional energy loss.

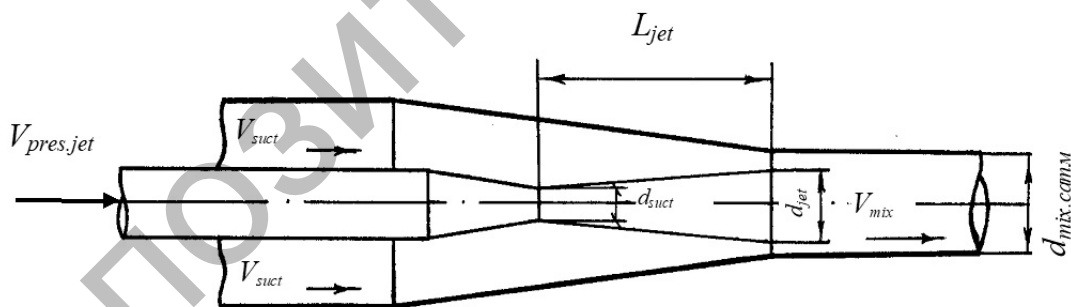

Fig.7. Calculation scheme for determining the optimal nozzle positions

If, as a result of the calculation, it turns out that $d_{jet} > d_{mix.cam}$ then the distance from the nozzle to the mixing chamber is increased by the value of l'_{jet}

$$l'_{jet} = (d_{jet} - d_{mix.cam}) / 2. \quad (5)$$

For the studied design of the vortex hydraulic elevator, the value of l_{jet} can be obtained using the formula

$$l_{cm} = 1.43d_{nozz}(0.079 + q) \quad (6)$$

The twist intensity is characterized by the twist parameter S, which is the dimensionless ratio of the axial component of the moment of flow momentum to the multiplication of the axial

component of the momentum flow and the equivalent nozzle radius [2]. For the vortex hydraulic elevator, the twist parameter is defined as:

$$S_{act} = \frac{\frac{F_{act}}{2}}{1 - \left(\frac{F_{act}}{2}\right)^2}, \quad (7)$$

$$S_{passiv} = \frac{\frac{F_{pass}}{2}}{1 - \left(\frac{F_{pass}}{2}\right)^2}, \quad (8)$$

where $F_{akt} = \frac{V_w^a}{V_o^a}$ и $F_{pass} = \frac{V_w^n}{V_o^n}$ and is the ratio of circumferential and axial velocities of active and passive flows.

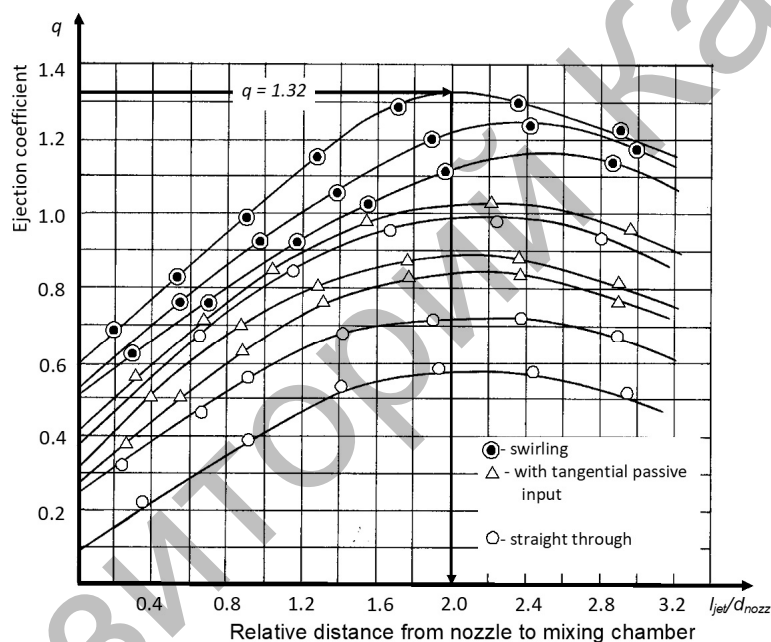

Fig.8. Graph of $l_{jet}/d_c=f(q)$ to determine the optimal distance from the nozzle to the mixing chamber.

Figures 9–11 show the graphs of $q_{suct}=f(S_{act})$, $q_{suct}=f(S_{pass})$, and $q_{suct}=f(S_{act}/S_{pass})$ at various distances from the nozzle section to the throat of the mixing chamber for a vortex hydraulic elevator.

In Figure 12, the dependence curve $q_m=f(S)$ for a hydraulic elevator with tangential entry of a passive medium. As can be seen from the graphs, for the vortex hydraulic elevator the optimal distance from the nozzle to the throat is 30 mm, and the ejection coefficient is $q_{suct}=1.32$. For a hydraulic elevator with a tangential entry of a passive medium, the optimal distance is 20 mm, with $q = 1.01$.

The analysis of the curves of dependences $q_{suct}=f(S_{act})$, $q_{suct}=f(S_{pass})$, $q_{suct}=f(S_{act}/S_{pass})$ and $q_m=f(S)$ allows us to conclude that there are critical values, $S_{kp}^{akt} = 0.11$, $S_{kp}^{nac} = 0.225$, $S_{kp}^{akt}/S_{kp}^{nac} = 0.48$, for the vortex hydraulic elevator.

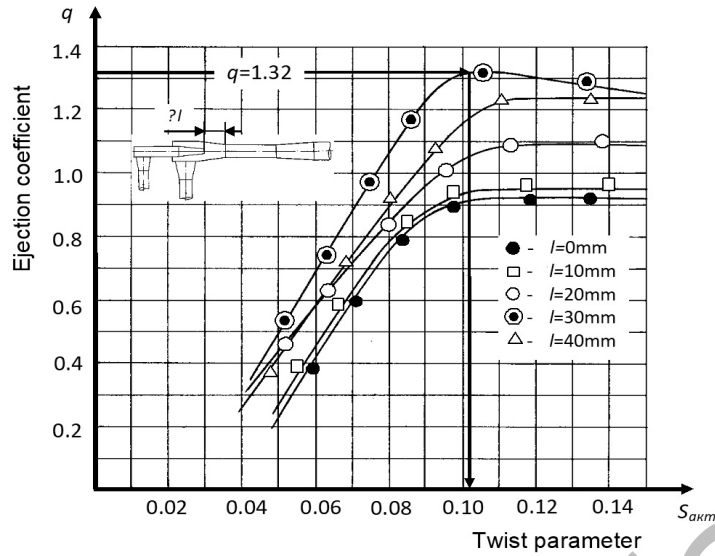

Fig. 9. The dependence of the ejection coefficient on the parameter active thread spins

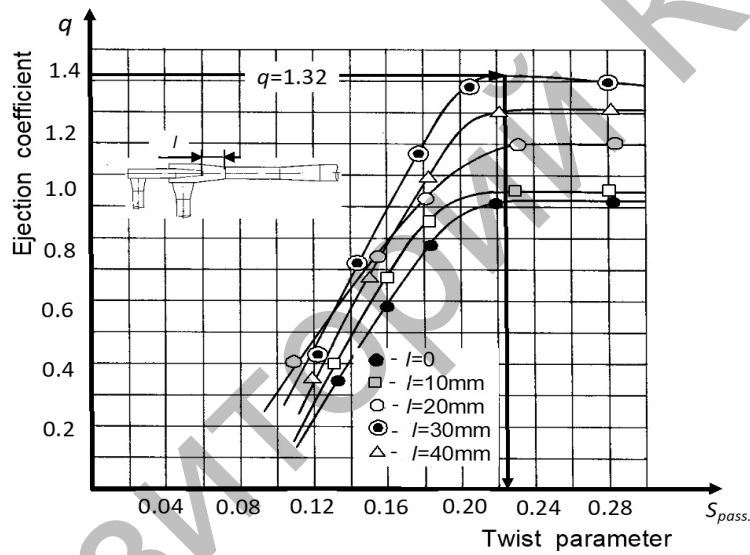

Fig. 10. Connection of the ejection coefficient with the twist parameter of passive stream

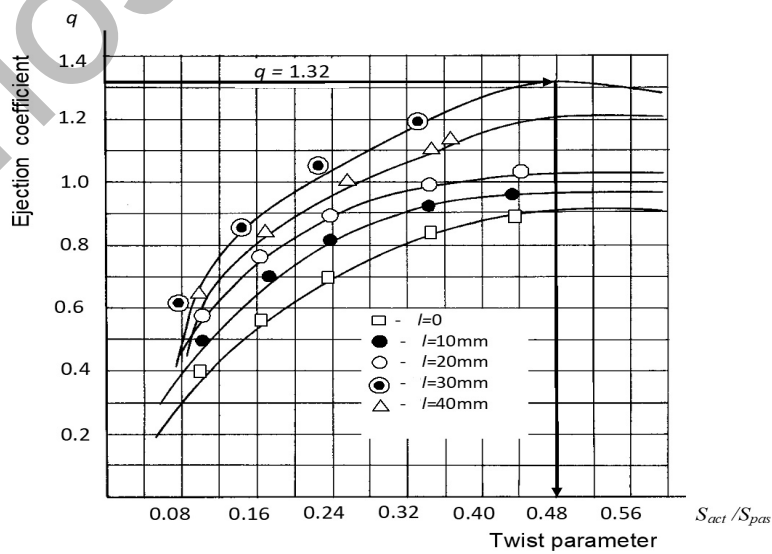

Fig. 11. Graph of $q_{suct} = f(S_{act}/S_{pass})$ dependence.

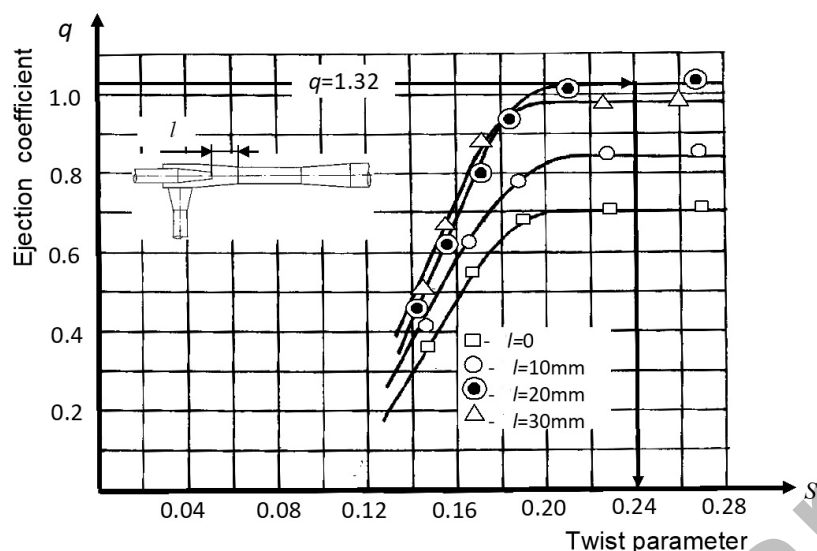

Fig. 12. Dependence of the ejection coefficient on the twist parameter of intake medium

So, $S_{kp}=0.24$ for a hydraulic elevator with a tangential intake of the intake medium at which the highest value of the ejection coefficient is achieved.

Conclusion

Analysis of the research results allows us to conclude that the swirling of active and passive flows radically affect the mechanism for drawing the intake fluid into the mixing chamber of the hydraulic elevator. An increase in the swirling intensity increases the mixing of the flow, during which large pressure gradients occur not only in the axial but also in the radial direction, which leads to an increase in the ejection coefficient.

Due to the involvement of fluid particles in the boundary layer, the spreading in the mixing chamber will be not in the bulk of the stationary fluid, but in the co-drawn suction flow. In the vortex hydraulic elevator in the area between the nozzle section and the mixing chamber, the mutual penetration of active and passive helical flows occurs. The length of the path of interaction between the two-vortex flows will significantly increase compared with the distance from the nozzle exit to the beginning of the mixing chamber, as a result, the amount of the transmitted energy of the active passive flow will increase. Thus, the use of vortex hydraulic elevators in the hydro transportation of various mixtures will significantly reduce energy consumption and increase productivity.

REFERENCES

- 1 Lyamaev B.F. *Hydrojet pumps and installations*. Moscow, 1988, 277 p. [in Russian]
- 2 Gupta A., Lilly D., Seared N. *Swirling flows*. Moscow, Mir, 1987, 589 p. [in Russian]
- 3 Sokolov E.Ya., Zinger N.M. *Inkjet machines*. Moscow, Energy, 1970, 288 p. [in Russian]
- 4 Abduramanov A.A., Abirov A.A., Abduramanov E.A. *Jet pumps. Hydrocyclone pumping units. Pumping stations* (Analytical review). Taraz, 2003, 32 p.
- 5 Lesin A.V., Valeev S.I., Bulkin V.A. Prospects for the development of the separation of suspensions and emulsions in hydrocyclones. *Bulletin of the Technological University*. 2015, Vol. 18, No.10, pp. 55 – 57.
- 6 Basharov M.M., Sergeeva O.A. *Devices and calculation of hydrocyclones*. Kazan, 2012, 92 p.
- 7 Matvienko OV, Evtushkin E.V. Theoretical study of the cleaning process of oil-contaminated soil in hydrocyclone devices. *Engineering Physics Journal*. 2007, Vol. 80, No.3, pp.72 – 80.
- 8 Evtushkin E.V. *Mathematical modeling of the movement of the dispersed phase and separation in a hydrocyclone*. Thesis of the Ph.D. , Tomsk, 2007, 168 p.