



Received: 12/04/2024

Revised: 22/04/2025

Accepted: 25/09/2025

Published online: 30/09/2025

Research Article



Open Access under the CC BY -NC-ND 4.0 license

UDC: 536.24; 621.382.3

DESIGN ANALYSIS OF A WIEN-BRIDGE OSCILLATOR: FROM PROTOTYPE TO TEMPERATURE PERFORMANCE

Usibe B.E.¹, Iserom B.F.¹, Iwuji P.C.^{1*}, Aigberemhon M.E.², Iwuanyanwu I.O.³,
Ushie A.I.⁴, Ettah E.E.⁴

¹Department of Physics, University of Calabar, Nigeria

²Department of Electrical and Electronics Engineering, University of Cross River State, Nigeria

³Department of Geography & Environmental Science, University of Calabar, Nigeria

⁴Department of Philosophy of Science, University of Calabar, Nigeria

*Corresponding author: pciwuji@unical.edu.ng

Abstract. A prototype Wien-bridge oscillator was designed and constructed using a single Op-Amp with a diode-bridge included in the degenerative-feedback path to provide amplitude stabilization of the output oscillations. A circuit simulator, PSpice version 10.0P was also used to simulate the circuit. The simulated results were compared with those measured with an oscilloscope for validation, and it had 90% accuracy. The relationships between the operating temperature and the settling time of the oscillator, as well as the resonant frequency, were investigated and derived. The resonant frequency of the constructed oscillator is adjustable between 142.86Hz and 16.67KHz. The prototype circuit in this work that measures this range of frequencies was successfully analyzed, and the investigated effects of temperature variations on the output signals are presented in section 3. The results of the temperature response to the output bias voltage, source currents, and total power dissipation of the circuit are also presented. The overall results of the presented parameters show that the operating temperature of the oscillator (within a temperature limit) has an unpredictable effect on its output, which could adversely affect the performance of the oscillator where precision is of great importance.

Keywords: Wien-Bridge Oscillator, Temperature Stability, Resonant Frequency, Transient Response, Circuit Simulation, PSpice

1. Introduction

An oscillator is an electronic circuit that creates a continuous alternating current waveform output when supplying power via a direct current input. This work that was developed to promote technical skills in circuit design and prototyping and to expand the limits of the development of local content in Nigeria consists of a direct current supply as the only external source of the oscillator. This was achieved by conversion of the alternating current supplied by the power grid (from the electricity supply company) into direct current [1]. One could question the need to convert the direct current back into an alternating current using the oscillator after the initial conversion process. The problem is that the alternating current supplied by the source companies in Nigeria, Europe and the United Kingdom works with a fixed frequency of 50 Hz (60 Hz in some other countries), while many devices such as electronic circuits, laboratory devices,

communication systems and microwave devices require internally generated frequencies in the range from 300 MHz to 1 GHz or higher. It is, therefore, important to have a device that can generate these frequencies.

On the other hand, a Wein-bridge oscillator is an electronic oscillator that generates sinus waves and uses a two-stage RC amplifier circuit, has a high-quality resonance frequency, low distortion and is useful when voting. It is an oscillator type that uses a resistance-capacitor network (RC) instead of the conventional inductor-capacitor swinging circle (LC) to create a sinus-shaped output waveform [2]. The Wein-Bridge, an alternating current version of the popular wheat stone bridge, is a combination of a standard/parallel RC network that is balanced at the frequency $f_o = 1/2\pi RC$ [3]. Using the Wein-Bridge as positive feedback, the frequency-selective network creates an oscillator that works according to the Vienna Bridge principle with suitable negative feedback (resistance or non-linear network) with suitable negative feedback (resistance or non-linear network); Wein-Bridge-Oscillator [4].

The use of an operational amplifier in a Vienna Bridge Oscillator is one of the available methods for the construction of an oscillator. The project therefore aimed to use discrete components to create a prototype circuit that can measure a large range of frequencies by generating sinus waves, the results of which match the existing literature and also to examine how the results of the output signals can be influenced by different operating temperatures. Therefore, the main focus of this work is to simulate and create a prototype circuit with surgical amp and other discrete components and to examine the effect of temperature changes on the output of the Wein-Bridge Oscillator. The simulated results using PSPICE are then compared with those measured with the oscilloscope for validation.

Many RC oscillators, including the Wein-Bridge Oscillator, control the vibration amplitude by integrating a temperature-sensitive resistance into the negative feedback loop. Thermistors and tungsten lamps are typically used for this purpose, and some studies on the behavior of the Win lamp were carried out in a Wein-bridge oscillator and the effects of the temperature on the output of the oscillator [5]. In addition, [6] presented an RC oscillator that should maintain a stable frequency over a wide temperature range. The authors used a self-calibration oscillator to achieve $\pm 0.4\%$ temperature stability from 55°C to 125°C . This is a great example of how oscillator design can ensure low distortion even with temperature changes. [7] and [8] have also done some work on various aspects of Wein-bridge oscillators, including the use of temperature-sensitive RC networks in the negative feedback loop. They also provided solutions for the design and operation of Vienna bridge oscillators, taking into account temperature effects and component selection.

Temperature changes can influence the outcome of a Wein-Bridge oscillator by changing the resistance of the temperature-sensitive components, which influences the automatic reinforcement and negative feedback mechanisms. These changes can, in turn, influence the frequency and amplitude of the oscillator [2]. For example, the resistance of a resistance changes with temperature and influences the resonance frequency and amplitude of the oscillator. Similarly, the capacity of a capacitor can also vary with the temperature and influence the resonance frequency and amplitude of the oscillator. This is due to a temperature-dependent RC time constant and a fixed input frequency to attribute to the middle frequency of the oscillator. One significant aspect of considering the temperature effects on the output of a Wien-bridge oscillator is that the circuit's temperature-dependent properties can be used for measurement purposes in specific applications like temperature sensors [7, 8].

In summary, the impact of temperature on a Wien-bridge oscillator is mainly associated with the components used in the circuit, such as resistors, capacitors, and incandescent lamps used for automatic gain control. These components react to temperature changes in a way that contributes to maintaining the stability of the oscillator output and the low distortion [8]. However, fluctuating temperatures can affect the components of the oscillator, in particular the resistance and capacitors, which in turn can affect the outcome of the oscillator. In view of the fact that extreme temperature fluctuations could possibly affect the performance of the oscillator, it is recommended to select components based on the temperature range specified by the manufacturer during the design phase of electronic circuits in order to ensure optimal performance and longevity [9]. It is, therefore, important to take into account and examine the effects of the temperature when designing and operating a Wein-bridge oscillator and how these temperature changes change the output of the oscillator, especially if it is to be used in environments with considerable temperature fluctuations.

In order to simulate the behavioral properties of the oscillation circuit, the PSPICE simulator was used to record potential problems in design before the PCB was established. The PSPICE is a circuit simulation

program that affects a personal simulation program with an integrated circulation [10]. The use of the PSPICE simulator works for the Wein-ridge oscillator when reaction to each DC input in the operational amplifier by using models to display the components in the literature. PSPICE was used in [11] to emulate operational amplifiers in which the distortion of audio signals in a circuit was recognized via a wide frequency range. [12] also used an interactive ambient design of PSPICE to examine the parameters and properties of operational amplifier circuits and the various variants of trans-impedance amplifiers with photodiodes. In particular, an analogous PSPICE macro model technique was presented for the parametric dependence of the surgical ampere [13], which uses an easy use of internal equations in both time and frequency domains for non-linear control of voltage and power sources. The macro-model, which made up the temperature dependencies of the main amplifiers' electrical parameters, resulted in the basis of this work. The PSPICE simulator is one of the many commercial software programs available for engineers who can increase the design efficiency, save time and reduce defects and electronic waste. For recent applications of the PSPICE software in electronic circuit design, see [14]. Also, see [15] for details on other simulation and modelling techniques of electronic circuits.

Although the first operational amplifiers used complex vacuum tubes [16], they are versatile in their applications; they can sum, integrate, differentiate, or amplify a signal. These are the reasons they are termed operational amplifiers [17 - 19].

The pin configuration and circuit symbol of a typical eight-pin dual-in-line package (DIP) of an Op-Amp used in this project was adopted from [17]. Terminal 8 is unused, and terminals 1 and 5 are of little importance to this work. The five essential terminals include;

- Inverting input; pin 2: an input signal applied to this terminal appears inverted at the output.
- Non-inverting input; pin 3: signal applied to this terminal appears with the same polarity at the output.
- Other terminals include:
 - Output; pin 6
 - Positive power supply; pin 7
 - Negative power supply; pin 4.

1.1 Op-amp operating mode and oscillator gain

As an active element, the Op-Amp must be powered by a voltage supply ($\pm V_{cc}$). One practical limitation worth noting here is that the magnitude of its output voltage cannot exceed $|V_{cc}|$ [20], [21]. In other words, the output is dependent on and is limited by the magnitude of the power supply voltage. Depending on the differential input voltage (V_d), an Op-Amp can operate in:

$$\text{Positive saturation mode; } V_o = V_{cc} \quad (1)$$

$$\text{Linear mode; } -V_{cc} \leq V_o = G \cdot V_d \leq V_{cc} \quad (2)$$

$$\text{Negative saturation region; } V_o = -V_{cc} \quad (3)$$

In this work, it is assumed that Op-Amps operate in the linear mode. Thus, the output voltage of the oscillator is restricted by equation (1).

Applying the Op-Amp in any electronic circuit design involves configuring the Op-Amp as either an inverting amplifier with voltage gain;

$$G_v = \frac{V_o}{V_i} = -\frac{R_f}{R_i} \quad (4)$$

Or as a non-inverting amplifier with a voltage gain given as [14].

$$G_v = V_o/V_i = 1 + R_f/R_i \quad (5)$$

However, for sustained oscillation, the loop gain of the circuit must satisfy the Barkhausen criterion as shown in Equation 5, where R_f and R_i are resistors in the gain feedback network.

2. Materials and methods

The materials used during the construction of the circuit include electronic components listed in section 3.2, soldering iron, soldering lead, soldering pump, side cutter, picker, digital multi-meter, sandpaper, technician knife, laser jet printer, 12V mini hand-drill machine, electric iron, copper board, PCB foil, ferric chloride, as well as plastic Perspex and Uhu-plast adhesive gum for the casing and finishing. The construction was carried out in stages, which included the power supply, the oscillator circuit, amplitude

stability, printed circuit board, and finally, the assembling stage. The block diagram of the Wien-bridge oscillator is shown in Figure 1.

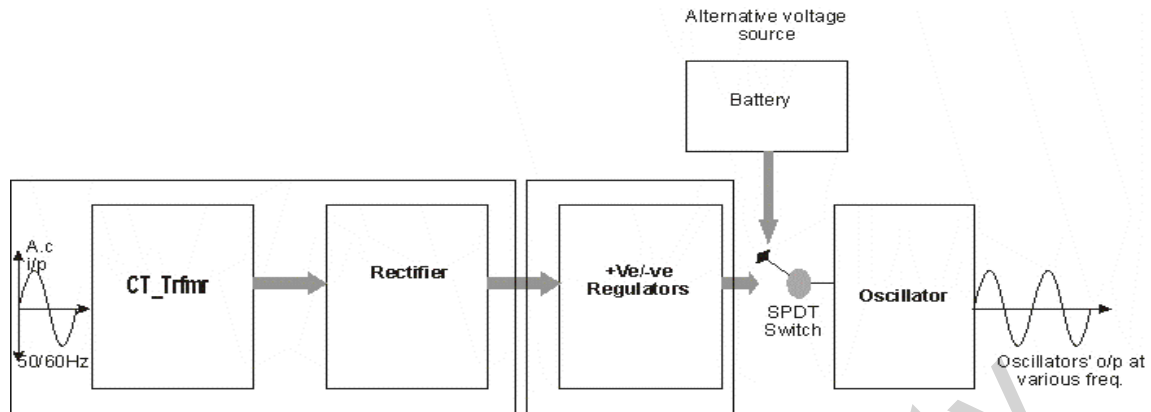

Fig.1. Block Diagram of the constructed Oscillator

2.1 Design methodology

Designing the Wien-bridge oscillator revolves around the operational amplifier (Op-Amp) IC chip [22], [23]. For this work, an Op-Amp (UA741 model) was used. It is an 8-pin DIP IC with a high input voltage range, high input impedance, and excellent temperature stability [17]. To determine the frequency of resonance (f_o), equation (6) was employed [24], [25] with a fixed capacitor $C = 22nF$ and a dual-gang variable resistor $R = 50K\Omega$.

$$\omega_o = 1/RC = 2\pi f_o \tag{6}$$

Thus, f_o can be varied for a range of frequencies determined by the variation in R.

Let $f_{o(min)}$ be the minimum frequency obtainable for the maximum value of R called $R_{(max)}$

$$f_{o(min)} = \frac{1}{2\pi R_{(max)}C} = \frac{1}{2 * \pi * 50 * 10^3 * 22 * 10^{-9}} = 145Hz \tag{7}$$

The maximum resonance frequency $f_{o(max)}$ is obtained when R is minimum (i.e. at $R_{(min)}$) thus:

$$f_{o(max)} = \frac{1}{2\pi R_{(min)}C} = \frac{1}{2 * \pi * 390 * 22 * 10^{-9}} = 18.5KHz \tag{8}$$

Note: $R_{(max)} = 50K\Omega$, $R_{(min)} = 390\Omega$ and $C = 22nF = 22 * 10^{-9}F$

From Equation 5, where the amplitude gain is determined, the oscillator was found to produce fine-tuned oscillation with the chosen value of capacitance, C. To satisfy the Barkhausen criterion and keep the overall gain of the circuit as 1, the Op-Amp must compensate by providing a gain of 3 or greater [3, 26]. In other words, the amplifier gain must initially be set to 3 to start oscillation. This was achieved using equation 9, which is critical to maintaining oscillations and keeping the circuit stable at the desired frequency.

$$R_f = 2R_i \tag{9}$$

For numerical convenience and design purpose, R_i was chosen to be $10K\Omega$, thus, $R_f = 2 * 10K = 20K\Omega$.

Where R_f is the feedback resistor connected from the output to the inverting input of the Op-Amp and R_i is the resistor connected from the inverting input to the ground. The overall circuit is shown in Figure 2.

2.2. Construction steps

The building of the Wien-bridge oscillator involved the assembling of discrete components on a Printed Circuit Board (PCB), which was prepared before this construction using the method carefully adopted from [27 - 30]. A summary of the components used for the construction is given below.

Resistors	Voltage Regulators	Capacitors	Diodes
10K Ω x 2 (fixed)	LM317	22nF x 2 (fixed)	1N4007 x 10
1K Ω x 1 (fixed)	LM137	100 μ F/35v x 2 (fixed)	IC
50K Ω x 2 (dual-gang variable)	Transformer	10 μ F/35v x 2 (fixed)	UA741 Op-amp
220 Ω x 3 (fixed)	15V/2A (center-taped)	2500 μ F/35v x 2 (fixed)	

The layout of the fabricated circuit is shown in Figure 2.

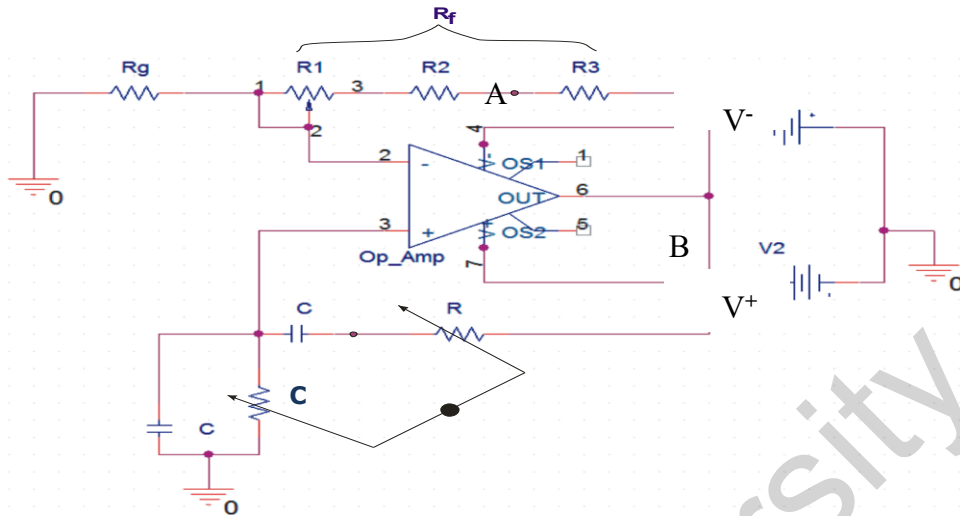

Fig. 2. Prototype Wien-bridge Oscillator using Op-Amp (Designed with PSPICE)

3. Results and discussion

Simulations were carried out on the Wien-bridge circuit using an equivalent model circuit with 90% accuracy. The value of the Resistor, R was fixed at $10\text{K}\Omega$ and the Capacitor, C at 22nF in the modeled circuit. Measurements were initially made at room temperature, and subsequently at varying operating temperatures. Meanwhile, software limitations [31-33] placed some restrictions on the number of components that could be simulated in a single circuit diagram. So, the Wien-bridge was simulated without the amplitude stability and the power supply sections of the circuit, and these had no significant effects on the results. The results obtained are presented in the succeeding sections.

3.1. The oscillator output from PSPICE simulation at room temperature

Figure 3 shows the sinusoidal output obtained by simulation with PSPICE at room temperature (27°C). Here, V_{cc} was set to $\pm 10\text{V}$, and the results of oscillation between $t = 0$ second and $t = 100$ milliseconds were skipped. This was because resultant waveforms within this time interval were found to be unstable and very low in amplitude.

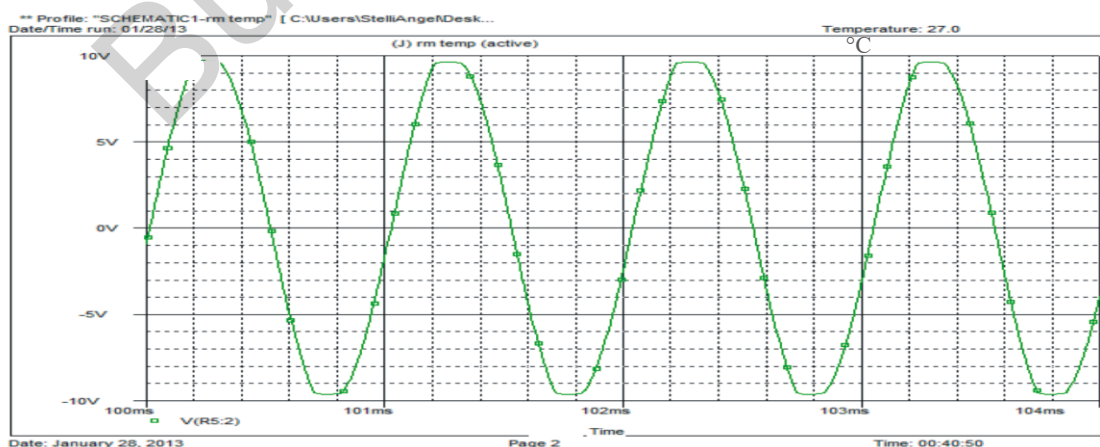

Fig. 3. Oscillator Output Waveform at Room Temperature from PSPICE ($V_{cc} = \pm 10\text{V}$)

3.1.1. The oscillator output from oscilloscope

The image shown in Figure 4 is the output waveform obtained from the oscilloscope screen. It should be noted that this output was obtained from the complete oscillator circuit.

Figure 5 shows the prototype of the Wein-bridge oscillator.

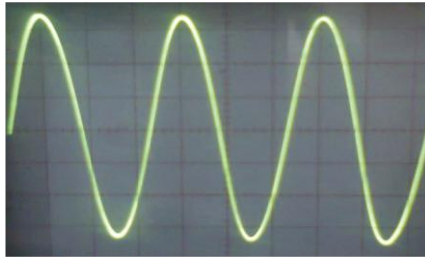

Fig. 4: Output Waveform of Wien-bridge Circuit

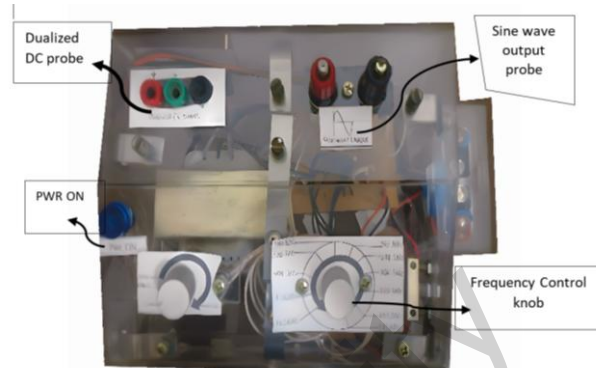

Fig. 5: Prototype Wien-bridge oscillator

3.1.2. Comparison of the PSPICE and oscilloscope outputs

The output waveforms from PSPICE and the measurement from the oscilloscope are shown in Figures 3 and 4, respectively. The output waveform of Figure 3 is seen to have flat amplitudes. This was because the diode bridge was not included in the circuit during the PSPICE simulation due to software limitations. In contrast, Figure 4 (output from the oscilloscope) shows a noise-free amplitude-stable waveform. This was because a diode-bridge was added to the Wien-bridge circuit before this oscilloscope output was obtained. Otherwise, both Figure 3 and Figure 4 are similar and they represent the desired sine wave outputs.

3.1.3 Results of DC bias point

The results shown in Table 1 were obtained by analyzing the circuit's response to the basic DC sources, operating in conjunction with the resistive elements in the circuit at different temperatures. Parameters of interest (i.e., output bias voltage, source currents, and total power dissipation of the circuit) and how they are affected by temperature changes are extracted and summarized in Table 1. This result shows that a change in the operating temperature of the oscillator affects the bias voltage of the oscillator circuit minimally but in an unpredictable manner. This effect may not be considered significant but could have adverse effects where precision is of great importance. The results further show that the source currents and total power dissipated in the circuit remain constant for a wide range of temperatures (-125°C to 200°C) and increase slightly at temperatures above 200°C.

Table 1. Results of DC Bias Point

Temperature (°C)	Voltage at output (μV)	Source current (mA)		Total power dissipation (mW)
		V ⁺	V ⁻	
-125.0	-736.9	-1.006	-1.006	18.0
-100.0	-735.7	-1.006	-1.006	18.0
-75.0	-735.0	-1.006	-1.006	18.0
-50.0	-734.8	-1.006	-1.006	18.0
-25.0	-735.2	-1.006	-1.006	18.0
0.0	-735.2	-1.006	-1.006	18.0
25.0	-735.1	-1.006	-1.006	18.0
50.0	-734.8	-1.006	-1.006	18.0
75.0	-734.5	-1.006	-1.006	18.0
100.0	-734.0	-1.006	-1.006	18.1
125.0	-733.5	-1.006	-1.006	18.1
150.0	-732.7	-1.006	-1.006	18.1
175.0	-731.5	-1.006	-1.007	18.2
200.0	-730.0	-1.006	-1.007	18.2
225.0	-729.0	-1.007	-1.008	18.3

3.2. Transient Response at Different Temperatures

A transient time analysis was carried out on the circuit with a temperature sweep for a range of temperatures of -125°C to -300°C . The run time was 600ms and data were recorded from $t = 100\text{ms}$. The maximum step size was set to $10\mu\text{s}$. A summary of the results obtained is shown in Table 2.

Table 2. Temperature Sweep for transient time, $t = 0$ to $t = 600\text{ms}$.

T ($^{\circ}\text{C}$)	t (ms)	T ($^{\circ}\text{C}$)	t (ms)
-125.0	350.0	100.0	310.0
-100.0	260.0	125.0	320.0
-75.0	300.0	150.0	318.0
-50.0	240.0	175.0	330.0
-25.0	270.0	200.0	340.0
00.0	276.0	225.0	375.0
25.0	280.0	250.0	348.0
50.0	288.0	275.0	376.0
75.0	300.0	300.0	335.0

Table 2 shows that transient time, t (ms) increases for a range of temperatures, T (-50°C to 125°C) and becomes unpredictable beyond this range. Thus, it was deduced that: if 't' is the amplitude stability time (settling time) in milliseconds, and 'T' is the operating temperature of the oscillator in degrees Celsius, then

$$t \propto T \quad \text{Provided } (-50^{\circ}\text{C} \leq T \leq 125^{\circ}\text{C}) \quad (10)$$

Then,

$$t = ZT, \quad (11)$$

where Z is a constant

Equation (11) shows that for a unit time $t = 1\text{ms}$ and a unit temperature $T = 1^{\circ}\text{C}$,

$$Z = t/T \text{ (ms}/^{\circ}\text{C}) \quad (12)$$

Equation (12) shows how the amplitude stability time is affected by a change in the operating temperature of the oscillator.

3.3. Results of Resonant Frequency from Fourier Analysis

Fast Fourier analysis was performed for the transient results presented in Table 2 using PSPICE, and the corresponding resonant frequencies (f_o) were recorded in KiloHertz (KHz) against the operating temperatures ($T^{\circ}\text{C}$) as shown in Table 3.

Table 3. Resonant Frequencies at Different Temperatures

T ($^{\circ}\text{C}$)	f_o (kHz)	T ($^{\circ}\text{C}$)	f_o (kHz)
-125.0	0.720	100.0	0.720
-100.0	0.720	125.0	0.718
-75.0	0.720	150.0	0.718
-50.0	0.720	175.0	0.718
-25.0	0.720	200.0	0.718
00.0	0.720	225.0	0.00
25.0	0.720	250.0	0.250
50.0	0.720	275.0	0.275
75.0	0.720	300.0	0.300

Results presented in Table 3 show that the resonant frequency is constant, provided $-125^{\circ}\text{C} \leq T \leq 100^{\circ}\text{C}$. That is

$$f_o = \beta \quad \text{Provided } (-125^{\circ}\text{C} \leq T \leq 100^{\circ}\text{C}), \quad (13)$$

where β is a constant with a unit in kHz.

Comparing Equation (13) and Equation (6), it can be seen that;

$$\beta = \frac{1}{2\pi RC} \quad (14)$$

Since R and C are known variables, β can be found from equation (14) as the resonant frequency.

4. Discussions

The DC bias point is crucial for proper circuit operation, particularly in oscillators like the Wien-Bridge. It determines the amplifier's operating point, affecting linearity and gain. Maintaining a stable bias point ensures consistent performance across varying temperatures. Table 1 illustrates the Wien-Bridge oscillator's thermal stability. The output voltage slightly decreases from $-736.9 \mu\text{V}$ at -125°C to $-735.2 \mu\text{V}$ at 0°C , reflecting minor but significant temperature-induced effects. This change, influenced by the temperature coefficients of circuit components, demonstrates adequate stability within the design's limits. However, a sharper decline to $-175 \mu\text{V}$ at 225°C suggests the need for optimization at extreme temperatures due to parasitic effects. The source currents ($V+$ and $V-$) remain stable ($\sim 1.006 \text{ mA}$) across the temperature range, ensuring consistent gain and reliable operation. Power dissipation stays nearly constant at 18 mW , with only a slight increase to 18.3 mW at 225°C , indicating high thermal efficiency. Overall, these results confirm a robust DC bias design suitable for the oscillator's intended range.

Transient response data in Table 2 reveal the relationship between temperature and settling time. Within -50°C to 125°C , settling time exhibits a linear trend, increasing from 240.0 ms to 320.0 ms as temperature rises. Beyond this range, transient behavior becomes unpredictable, highlighting the circuit's limitations at extreme temperatures. This nonlinearity may result from temperature-dependent variations in transconductance and carrier mobility, impacting active components.

The linear trend in settling times applies between -50°C and 125°C . Beyond this range, transient times become unstable, with significant variations at extreme temperatures. For instance, the transient time at -125°C is 350.0 ms , longer than 276.0 ms at 0°C but comparable to 375 ms at 225°C . This unpredictability suggests interactions among multiple variables, possibly due to active component behavior deviating from designed conditions or parasitic effects in extreme temperatures. The data show that outside -50°C to 125°C , the oscillator's response is unreliable. This limitation highlights the need to understand safe operating conditions and manage thermal impacts effectively. Additionally, Table 2 validates equation (10) only within the linear range of -50°C to 125°C . Managing thermal conditions remains crucial for wide-temperature applications.

The resonant frequency of the Wien-Bridge oscillator is governed by its frequency-determining components, as shown in Table 3. Between -125°C and 100°C , the resonant frequency remains stable at 0.720 kHz . However, it decreases slightly to 0.718 kHz at 150°C and significantly drops beyond 225°C . By 250°C , the frequency plummets to 0.250 kHz , suggesting component degradation or parasitic effects leading to operational failure. Extreme temperatures affect resistance, capacitance, and active device parameters like transconductance, preventing oscillations.

In summary, the Wien-Bridge oscillator in the current work demonstrates robust performance and frequency stability within moderate temperature ranges up to 100°C . Beyond this threshold, temperature-induced effects degrade stability, and it becomes unpredictable, necessitating design improvements such as effective heat management strategies, enhanced component selection, or temperature compensation techniques. These adjustments are critical for extending the functionality of the oscillator in high-temperature environments and ensuring its reliability under diverse operating conditions.

5. Conclusion

Since temperature variation impacts electronic components, the frequency of oscillation also shifts slightly due to changes in resistance and capacitance. Therefore, modelling these variations helps predict the performance of an oscillator circuit under thermal stress. While it is easy to design and build a sine-wave oscillator, such as the Wien-bridge oscillator, the results obtained have shown that a change in operating temperature unpredictably affects the bias voltage at the oscillator's output.

Further investigation into the temperature effect has shown that the amplitude stability time (t) and the resonant frequency (f_0) of the oscillator are proportional to the temperature with a given temperature limit.

The DC bias or operating point results in Table 1 showed that a change in temperature affects the “bias voltage at the output” of the oscillator. Though this observed effect was minimal, its effect is unpredictable and could pose a great challenge if not taken into consideration where precision and accuracy are of great concern in circuit design. The result further showed that the source current and the total power dissipated in the circuit remained constant except at very high temperatures above 225°C. Similarly, Table 2 gives a relationship between the operating temperature ($T^{\circ}\text{C}$) and the stability time t (ms) of the oscillator. For temperatures greater than 125°C, the settling time becomes unpredictable. Therefore, equation (10) holds only when the operating temperature, T ($^{\circ}\text{C}$) lies in the range $-50^{\circ}\text{C}\rightarrow 125^{\circ}\text{C}$. As shown in Table 3, a change in the operating temperature of the oscillator also affects the resonant frequency (f_0) significantly for $T > 100^{\circ}\text{C}$.

Finally, in what follows the current work, implementing effective heat control strategies and utilizing electronic components with minimal temperature sensitivity is recommended to aid in reducing these impacts observed in the output results of the current work.

Conflict of interest statement

The authors declare that they have no conflict of interest in relation to this research, whether financial, personal, authorship or otherwise, that could affect the research and its results presented in this paper.

CRedit Author Statement

Usibe B.E.: Conceptualization, Methodology, Supervision, Writing – review & editing; **Iserom B.F.:** Investigation, Formal analysis, Data curation, Visualization; **Iwuji P.C.:** Validation, Software, Formal analysis, Project administration, Writing – review & editing; **Aigberemhon M.E.:** Investigation, Resources, Writing – original draft; **Iwuanyanwu I.O.:** Data curation, Methodology, Writing – original draft; **Ushie A.I.:** Software, Validation, Resources; **Ettah E.E.:** Supervision, Funding acquisition, Writing – review & editing. The final manuscript was read and approved by all authors.

Acknowledgements

We sincerely thank the technologist and technicians in the Electronics Laboratory, Department of Physics, University of Calabar, Nigeria, for their consistent efforts in ensuring the laboratory was always ready for use and for their encouragement throughout the course of this work.

We also extend our appreciation to the other staff members of the department and other colleagues and acquaintances for their valuable support.

References

- 1 Moore J.H., Davis C.C., Coplan M.A., Greer S.C. (2009) Building Scientific Apparatus: A Practical Guide to Design and Construction., Cambridge: Cambridge University Press. Available at: https://assets.cambridge.org/9780521878586/frontmatter/9780521878586_frontmatter.pdf
- 2 Electronic Tutorials. (2023) Wien Bridge Oscillator Tutorial and Theory. Available at: <https://www.electronicstutorials.ws> [Accessed: 26-Jan-2023].
- 3 Sedra A.S., Smith K.C. (2020) Microelectronics Circuits: Introduction to Modern Electronics., Oxford University Press. Available at: <https://books-library.website/files/books-library.net-02131527Lf1G9.pdf>
- 4 Razavi B. (2021) Fundamentals of Microelectronics. John Wiley & Sons. Available at: <https://scholar.google.com/scholar?q=Razavi+B,+2021+Fundamentals+of+Microelectronics>
- 5 Skillen R.P. (1964) Transient Stability of the Wien Bridge Oscillator. MSc Thesis, McMaster University, Hamilton, Ontario
- 6 Wang J., Koh L.H., Goh W.L. (2015) A 13.8-MHz RC Oscillator with Self-Calibration for $\pm 0.4\%$ Temperature Stability from -55 to 125°C . *IEEE Int. Conf. Electron Devices Solid-State Circuits (EDSSC)*, 423-428. Available at: [A 13.8-MHz RC oscillator with self-calibration for \$\pm 0.4\%\$ temperature stability from \$-55\$ to \$125^{\circ}\text{C}\$ | Request PDF](#)
- 7 Pan S., Makinwa K.A.A. (2022) Wien Bridge-Based Temperature Sensors. *Resistor-Based Temperature Sensors in CMOS Technology, Analog Circuits and Signal Processing*, Springer. https://doi.org/10.1007/978-3-030-95284-6_3
- 8 Cristiano G., Livanelioglu C., Ji Y., Liao J., Jang T. (2023) RC Oscillators with Non-linear Temperature Compensation. *Biomedical Electronics, Noise Shaping ADCs, and Frequency References*, Springer, Cham. https://doi.org/10.1007/978-3-031-28912-5_14
- 9 Li Y., Du K., Zhang J. (2022) Design of ring oscillator with temperature compensation effect. *Proceeding of the Int. J. RF Microw. Comput. Aided Eng.*, 32(11). <https://doi.org/10.1002/mmce.23374>

- 10 Cadence. (2022) How Does SPICE Simulation Work? Available at: <https://resources.pcb.cadence.com/blog/2022-how-does-spice-simulation-work> [Accessed: 9-Dec-2022].
- 11 Shamsir S., Hasan M.S., Hassan O., Paul P.S., Hossain M.R., Islam S.K. (2020) Semiconductor Device Modeling and Simulation for Electronic Circuit Design. *Modeling and Simulation in Engineering - Selected Problems, Intech Open*. <https://doi.org/10.5772/intechopen.92037>
- 12 Asadi F. (2023) Op Amp Circuits and 555 Timer IC. *Analog Electronic Circuits Laboratory Manual*, Springer, Cham. https://doi.org/10.1007/978-3-031-25122-1_6
- 13 Maxim A., Andreu D. (2000) A Unified High Accuracy Behavioral SPICE Macromodel of Operational Amplifiers Featuring the Frequency, Temperature and Power Supply Influences and the Monte Carlo Simulation. *Proceeding of the IEEE Int. Symp. Circuits Syst.*, 4, 697–700. Available at: <https://www.researchgate.net/publication/224066383>
- 14 Pandey O.N. (2022) PSPICE. *Electronics Engineering*, Springer, https://doi.org/10.1007/978-3-030-78995-4_8
- 15 Shehova D., Asparuhova K., Lyubomirov S. (2021) Study of Electronic Circuits with Operational Amplifiers Using Interactive Environments for Design and Analysis. *Proceeding of the 12th Nat. Conf. with Int. Participation (ELECTRONICA)*, 1–4. Available at: <https://scispace.com/papers/study-of-electronic-circuits-with-operational-amplifiers-170g62o5>
- 16 Darran D.R. (n.d.) Wien-bridge Oscillator Circuits. SlidePlayer. Available at: <https://slideplayer.com/slide/10856659/> [Accessed: 2-Oct-2021].
- 17 Nilsson J.W., Riedel S.A. (2020) Electric Circuits. Pearson Education Limited. Available at: [https://mrce.in/ebooks/Circuits%20\(Electric\)%2011th%20Ed.pdf](https://mrce.in/ebooks/Circuits%20(Electric)%2011th%20Ed.pdf)
- 18 Thomas R.E., Rosa A.J., Toussaint J.G. (2016) The Analysis and Design of Linear Circuits. John Wiley & Sons, United Kingdom. Available at: <https://picture.iczhiku.com/resource/eetop/sYITSqrrPjHwGvMN.pdf>
- 19 Huijsing J. (2017) Operational Amplifiers: Theory and Design. 3rd ed., Springer, Cham. <https://doi.org/10.1007/978-3-319-28127-8>
- 20 Ron M. (n.d.) Op-amps for Everyone: Texas Instruments. Available at: <http://www.alldatasheets.com> .
- 21 Bugg D.V. (2021) Electronics: Circuits, Amplifiers and Gates. CRC Press. <https://doi.org/10.1201/9780367807894>
- 22 Lee B. (2018) Solid-State Electronics: Theory and Methods. Intelliz Press, New York. Available at: https://books.google.com/books/about/Solid_state_Electronics_Theory_and_Metho.html?id=KMv8zgEACAAJ
- 23 Fiore J.M. (2021) Operational Amplifiers and Linear Integrated Circuits: Theory and Application. Available at: <https://eng.libretexts.org>
- 24 Theraja B.L., Theraja A.K. (2010) A Textbook of Electrical Technology. S. Chand & Co., New Delhi, India. Available at: <https://dl.ojocv.gov.et/admin/book/a-textbook-of-electrical-technology-volume-i-basic-electrical-engineering-b-l-theraj>
- 25 Usibe B.E., Adiakpan E.S., Obu J.A. (2013) Design, construction and testing of a vibrometer. *Lat. Am. J. Phys. Educ.*, 7(2). Available at: https://www.researchgate.net/publication/308355287_Design_construction_and_testing_of_a_vibrometer
- 26 Irwin J.D., Nelms R.M. (2020) Basic Engineering Circuit Analysis. John Wiley & Sons, United Kingdom. Available at: <https://www.wiley.com/en-us/Basic+Engineering+Circuit+Analysis%2C+12th+Edition-p-9781119502012>
- 27 PCB Design World. (n.d.) Home Made PCBs – A Step by Step Guide to Build PCBs in Your Home. Available at: <https://pcbdesignworld.com> [Accessed: 5-Oct-2023].
- 28 Sassanelli C., Rosa P., Terzi S. (2021) Supporting disassembly processes through simulation tools: A systematic literature review with a focus on printed circuit boards. *J. Manuf. Syst.*, 60, 429–448. <https://doi.org/10.1016/j.jmsy.2021.07.009>
- 29 Awasthi A.K., Zeng X. (2019) Recycling printed circuit boards. *Waste Electrical and Electronic Equipment (WEEE)*, Handbook, Woodhead Publ. Series, 311–325. Available at: https://primo.aalto.fi/discovery/fulldisplay?docid=cdi_elsevier_sciencedirect_doi_10_1533_9780857096333_3_287&contex
- 30 Kularatna N. (2019) Electronic Circuit Design: From Concept to Implementation. CRC Press, Boca Raton, FL. Available at: <https://www.routledge.com/Electronic-Circuit-Design-From-Concept-to-Implementation>
- 31 Pandiev I.M. (2021) Development of PSPICE Macromodel for Monolithic Single-Supply Power Amplifiers. 28th Int. Conf. Mixed Design of Integrated Circuits and System (MIXDES), Lodz, Poland, 178–183. <https://doi.org/10.23919/MIXDES52406.2021.9497565>
- 32 Al-Hashimi B. (2019) The Art of Simulation Using PSPICE: Analog and Digital. CRC Press. <https://doi.org/10.1201/9780367812188>
- 33 Yang W.Y., Kim J., Park K.W., Baek D., Lim S., Young J., Park S., Lee H.L., Choi W.J., Im T. (2020) Electronic Circuits with MATLAB, PSPICE and Smith Chart. John Wiley & Sons, Hoboken, NJ. <https://doi.org/10.1002/978111959896>

AUTHORS' INFORMATION

Usibe, Brian Elom – Ph.D.(Eng.), Registered Engineer, Lecturer, Department of Physics, University of Calabar, Calabar, Nigeria; Member: Nigerian Society of Engineers, Institution of Engineering and Technology, UK; Honorary Fellow: Institute of Policy Management Development; Scopus Author ID: 58528585100; <https://orcid.org/0000-0003-4388-2480>; beusibe@unical.edu.ng.

Iseroma, Benjamin F. – Master (Sci.), Researcher, Department of Physics, University of Calabar, Calabar, Nigeria; <https://orcid.org/0009-0004-1886-4808>; iserombenjamin@gmail.com

Iwuji, Prince Chigozie - Ph.D.(Sci.), Lecturer and Leading Researcher, Department of Physics, University of Calabar, Calabar, Nigeria; Scopus Author ID: 57739427700; <https://orcid.org/0000-0001-5715-9336>; pciwuji@unical.edu.ng

Moses, Aigberemhon E. – Master (Eng.), Lecture and Researcher, Department of Electrical and Electronics Engineering, University of Cross River State, Calabar, Nigeria; <https://orcid.org/0009-0007-3856-1312>; moscomag2k2@yahoo.com

Iwuanyanwu, Iheoma O. – Ph.D. (Sci.), Lecturer and Leading researcher, Department of Geography and Environmental Science, Faculty of Environmental Sciences, University of Calabar, Calabar, Nigeria. <https://orcid.org/0009-0006-1946-435X>; omaiwuanyanwu@gmail.com

Ushie, Abel Idagu – Ph.D. (Sci.), Lecturer II, Department of Philosophy, University of Calabar, Calabar, Nigeria; Member: Philosophical Association of Nigeria, Academic Staff Union of Universities; Scopus ID: 59380460700; <https://orcid.org/0000-0002-6524-217X>; abelushie@unical.edu.ng

Ettah, Emmanuel E. – Ph.D. (Sci.), Lecturer, Department of Philosophy, University of Calabar, Calabar, Nigeria; <https://orcid.org/0000-0001-5713-0373>; emmanuelettah@unical.edu.ng