

UDC 537.533.34

CALCULATION OF THE CHARGED PARTICLES TRAJECTORIES IN THE HEXAPOLE CYLINDRICAL FIELD

A.O.Saulebekov^{*}, S.N.Assylbekova^{**}, Zh.T.Kambarova^{***}, A.K.Tussupbekova^{***}

^{*}Lomonosov Moscow State University, Kazakhstan branch, Kajimukana str.11, Astana, 010010, Kazakhstan

^{**}Nazarbayev Intellectual School of Astana, Turkestan str. 2/1, Astana, 010000, Kazakhstan

^{***}Karaganda State University, Universitetskaya str. 28, Karaganda, 100028, Kazakhstan,
saulebekov@mail.ru

The approximate analytical method of the charged particles trajectories calculations in the hexapole cylindrical field has been described. The trajectories were determining with help of the optimally chosen power series segments superposition, the recurrent relation for the coefficients of the power series was found. It is presented detailed calculation of the charged particles trajectories for a scheme, based on the hexapole cylindrical field, which was not studied earlier. On the proposed methods the corpuscular optical schemes with the hexapole cylindrical field have been calculated. The proposed approximate analytical method allows to describe the trajectories of charged particles in these fields with high accuracy.

Keywords: energy analyzers, hexapole cylindrical field, charged particles, corpuscular optical schemes.

Introduction

The class of axial symmetrical Laplace fields, constructed on superposition of multipoles and electrostatic field of cylindrical type was offered in the work [1]. The investigation of electron-optical properties of the synthesized multipole cylindrical fields is of a practical interest to realize new systems of the charged particles beams energy analyses. The main difficulty at such system developing is a problem of analytical description of charged particle trajectories. The solution of this problem is needed to estimate aberrations, those define the limiting resolution of the focusing system.

The approximate analytical method of trajectories calculation for determination of the corpuscular optical parameters was worked out at computation of the mirror analyzers schemes, based on quadrupole cylindrical field [2]. By using suggested mathematical model, let's present trajectory calculation of charged particles motion in the hexapole cylindrical field (HCF). Its potential has the next form

$$U(r, z) = \ln r + \gamma U_h(r, z), \quad (1)$$

where

$$U_h(r, z) = \left\{ \left[z^2 - r^2/2 - 1/2 \right] \ln r + r^2/2 - 1/2 \right\} / 2 -$$

a circular hexapole [1], γ - its weight component.

Calculation of trajectories in a hexapole cylindrical field

Let us consider the motion of the charged particles in HCF (1), the scheme of that is given in fig.1. The field is formed in space between two axially symmetrical coaxial electrodes 2 and 3. The

inner cylindrical electrode of radius r_0 is grounded, and the outer electrode of curvilinear profile is under the potential U_0 , which has the same sign as the charges of the particles. It is convenient to shift the origin to the vertex of the trajectory 1 – a point m (fig.1), and use the coordinates x and ξ .

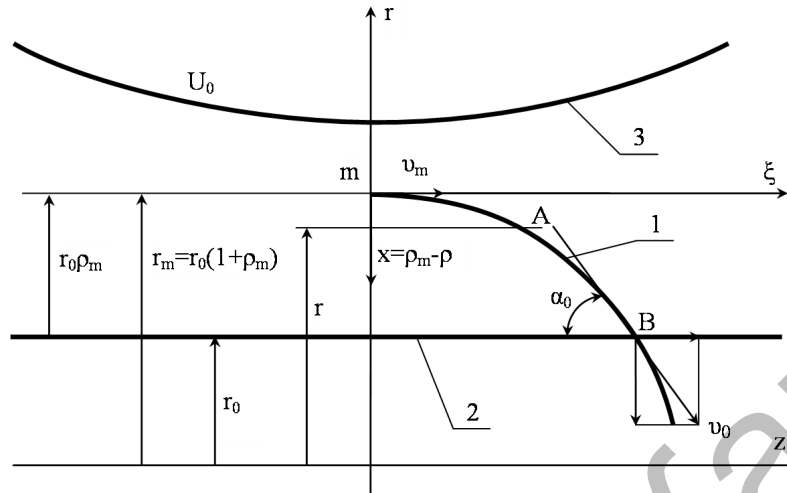

Fig.1. Trajectory of the charged particles in the hexapole cylindrical field

The mathematical transformations of the charged particles motion equations lead to the integral-differential equation of trajectories in the HCF (1)

$$4x \left(\frac{d\xi}{dx} \right)^2 \left[g(0) - g(x) - \int_0^x \varepsilon_2 \xi' dx \right] = 4x \left[P^2 ctg^2 \alpha_0 - \int_x^{\rho_m} \varepsilon_2 \xi' dx \right], \quad (2)$$

where

$$P = \sqrt{\frac{mV_0^2}{2qU_0}} \sin \alpha_0, \quad U(x, \xi) = U_0 g(x, \xi),$$

$$g(\xi, \rho) = g_c + \gamma g_h = \frac{\gamma}{2} \left\{ \left[\xi^2 - 1 + \frac{2}{\gamma} \rho - \frac{\rho^2}{2} \right] \ln(1 + \rho) + \frac{\rho^2}{2} + \rho \right\}.$$

The solution of the equation (2) was found with help of optimally chosen power series segments superposition in the form

$$\xi(x) = \sqrt{x} \sum_{n=0}^{\infty} C_n x^n \quad (3)$$

Therefore, the problem of trajectory calculation turns to determination of the coefficients C_n in the expression (3). Let us present some of the expansions, obtained at process of mathematical transformations

$$4x \left(\frac{d\xi}{dx} \right)^2 = h_0 + h_1 x + h_2 x^2 + h_3 x^3 + h_4 x^4 + h_5 x^5 + \dots,$$

$$g(0) - g(x) = \frac{\gamma}{2} \{-e_1 x - e_2 x^2 - e_3 x^3 - e_4 x^4 - e_5 x^5 - \dots\},$$

$$\int_0^x \varepsilon_2 \xi' dx = -\gamma \int_0^x \xi \xi' \ln(1 + \rho_m) dx = -\gamma \{b_1 x + b_2 x^2/2 + b_3 x^3/3 + b_4 x^4/4 + b_5 x^5/5 + \dots\}$$

We find an integral in the right part of equation (2)

$$\int_x^{\rho_m} \varepsilon_2 \xi' dx = \gamma \{-F(\rho_m) + b_1 x + b_2 x^2/2 + b_3 x^3/3 + b_4 x^4/4 + b_5 x^5/5 + \dots\},$$

where

$$F(\rho_m) = b_1 \rho_m + b_2 \rho_m^2/2 + b_3 \rho_m^3/3 + b_4 \rho_m^4/4 + b_5 \rho_m^5/5 + \dots$$

The right part of the equation (2) also can be presented in the form of power series

$$4x \left[P^2 \operatorname{ctg}^2 \alpha_0 - \int_x^{\rho_m} \varepsilon_2 \xi' dx \right] = 4 \left[P^2 \operatorname{ctg}^2 \alpha_0 + \gamma F(\rho_m) \right] x - 4\gamma b_1 x^2 - 2\gamma b_2 x^3 - 4\gamma b_3 x^4/3 - \gamma b_4 x^5 - \dots$$

Therefore, both parts of equation (2) are given in the form of power series. Then, by equating summands at the same powers x , we find the coefficients of series (3). Omitting intermediate mathematical operations, let us give the form of the coefficient C_0 and recurrent relation for the coefficients h_i . These coefficients are the function of the determining coefficients C_n

$$h_{i+1} = \frac{1}{b_1 - e_1/2} \left[-\frac{4}{i+1} b_{i+1} - \sum_{m=0}^i h_m \left(-\frac{1}{2} e_{i+2-m} + \frac{1}{i+2-m} b_{i+2-m} \right) \right], \quad (4)$$

$$C_0^2 = 4 \frac{P^2 \operatorname{ctg}^2 \alpha_0 + \gamma F(\rho_m)}{\frac{1}{1 + \rho_m} - \gamma \left[\frac{1 + \rho_m}{2} \ln(1 + \rho_m) + \frac{\rho_m^2}{4(1 + \rho_m)} - \frac{\rho_m}{2} \right]}.$$

To determine the next coefficients C_i the recurrent relation (4) is used. So, at $i=0$ we obtain

$$h_1 = \frac{1}{b_1 - e_1/2} \left[-4b_1 - h_0 \left(-\frac{e_2}{2} + \frac{b_2}{2} \right) \right],$$

$$C_1 = \frac{C_0}{6} \frac{9 \ln(1 + \rho_m) + 1 + \frac{C_0^2 - 1}{1 + \rho_m} - \frac{1}{2(1 + \rho_m)^2} \left(\rho_m^2 - \frac{4}{\gamma} \right)}{2(1 + \rho_m) \ln(1 + \rho_m) + \frac{1}{1 + \rho_m} \left(\rho_m^2 - \frac{4}{\gamma} \right) - 2\rho_m}$$

and at $i=1$ for h_2 and C_2 the next expressions are received

$$h_2 = \frac{1}{b_1 - e_1/2} \left[-2b_2 - h_0 \left(-\frac{e_3}{2} + \frac{b_3}{3} \right) - h_1 \left(-\frac{e_2}{2} + \frac{b_2}{2} \right) \right],$$

$$C_2 = \frac{C_0}{10} \left\{ -\frac{11 C_1}{2 C_0} \ln(1 + \rho_m) - \frac{3 C_1}{2 C_0} + \frac{1}{1 + \rho_m} \left[1 - \frac{C_0 C_1}{3} - \frac{3 C_1}{2 C_0} (C_0^2 - 1) \right] - \right.$$

$$\left. - \frac{C_0^2 - 1}{6(1 + \rho_m)^2} + \frac{1}{4(1 + \rho_m)^2} \left[3 \frac{C_1}{C_0} + \frac{1}{3(1 + \rho_m)} \right] \times \right.$$

$$\left. \times \left(\rho_m^2 - 4/\gamma \right) \right\} / \left\{ \rho_m/2 - \frac{1}{2} (1 + \rho_m) \ln(1 + \rho_m) - \frac{1}{4(1 + \rho_m)} \left(\rho_m^2 - 4/\gamma \right) \right\} - \frac{9 C_1^2}{10 C_0}.$$

Using introducing approach the following coefficients also can be calculated. In this work we restricted ourselves by the coefficients mentioned above.

Calculation of trajectories in a hexapole cylindrical field at $\gamma=1$

We present more detailed trajectory calculations for the case that was not studied earlier when the charged particles move in the field, having a potential described in the coordinate system r, z as follows:

$$U(r, z) = Lnr + U_h(r, z). \quad (5)$$

The scheme of energy analyzer of such field distribution is shown in fig.2. At definite relations between the geometrical and energy parameters of an analyzer, a charged particles beam from a ring source A is reflected by the field of mirror and focused to the ring image B.

For the further calculations we shift an origin of the trajectory in its vertex m , and place there the origin of the coordinates x, ξ . Here and further all linear dimensions will be expressed in the units of inner cylindrical electrode radius r_o

$$\frac{r}{r_o} = \frac{r_o + r_o \rho}{r_o} = 1 + \rho,$$

$$x = \frac{r_m - r}{r_o} = \rho_m - \rho, \quad \xi = \frac{z}{r_o}. \quad (6)$$

The distributions of HCF (5) in the coordinate x, ξ as follows:

$$U(x, \xi) = U_o g(x, \xi), \quad (7)$$

where

$$g(x, \xi) = \ln(R-x) \left[\frac{1}{2} \xi^2 - \frac{1}{4} (R-x)^2 + \frac{3}{4} \right] + \frac{1}{4} (R-x)^2 - \frac{1}{4}, \quad R = 1 + \rho_m \quad (8)$$

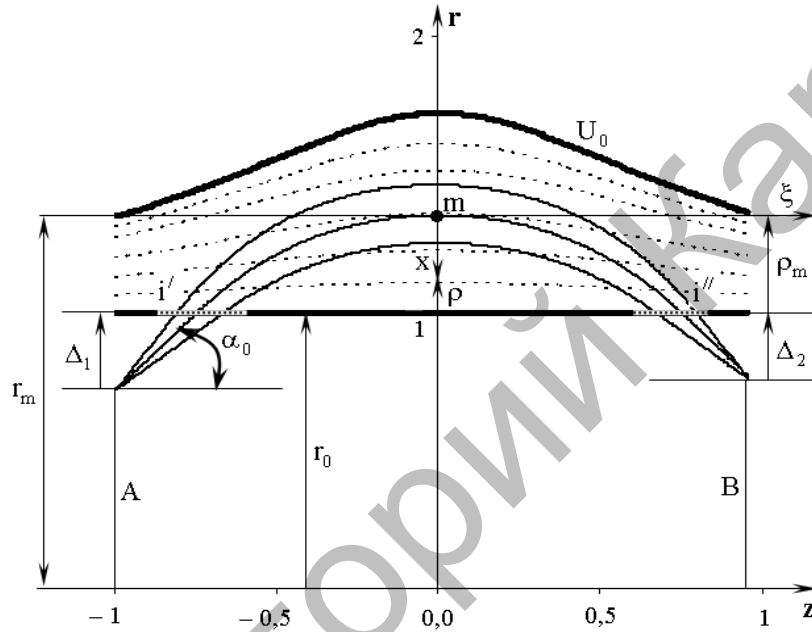

Fig. 2. Scheme of the energy analyzer based on HCF. A—source, i' -input ring slit, i'' - output ring slit, B—receiver

The motion of the charged particle in the field (8) is described by the system of equations

$$m\ddot{x} = qU_o \varepsilon_1, \quad \varepsilon_1 = -\frac{\partial g(x, \xi)}{\partial x}, \quad (9)$$

$$m\ddot{\xi} = qU_o \varepsilon_2, \quad \varepsilon_2 = -\frac{\partial g(x, \xi)}{\partial \xi}. \quad (10)$$

Integration of the sum of the equations (9) and (10) along a particle trajectory within the range from the vertex m to an arbitrary point, brings to the principle of energy conservation for a particle, moving in the electrostatic field. In the result we obtain the expression connecting change of kinetic energy with potential difference

$$\frac{mv_m^2}{2} - \frac{m}{2} \left(\dot{x}^2 + \dot{\xi}^2 \right) = -q (U_m - U) = -q U_o (g_o - g_x). \quad (11)$$

Here $U_m = U_o g(x_m, \xi_m) = U_o g_o$ - a potential of the field at the point m, where $x_m = \xi_m = 0$, $g_x = g(x, \xi(x))$.

We evaluate $\frac{m \dot{\xi}^2}{2}$ by integrating equation (10) within the range from m to an arbitrary point of trajectory. We take in account that $v_m^2 = \dot{\xi}_m^2 + \dot{x}_m^2 = \dot{\xi}_m^2$, since at the vertex of trajectory $\dot{x}_m = 0$. Using relation

$$\dot{\xi} = \frac{d\xi}{dt} = \frac{d\xi}{dx} \frac{dx}{dt} = \xi' \dot{x},$$

we obtain

$$\frac{mv_m^2}{2} - \frac{m \dot{\xi}^2}{2} = q U_o \int_x^{x_m} \frac{\partial g(x, \xi)}{\partial \xi} \frac{d\xi}{dx} dx = q U_o \int_o^x \text{Ln}(R-x) \xi \xi' d\xi. \quad (12)$$

According to fig.1 $\frac{m \dot{\xi}^2}{2} = W \cos^2 \alpha_o$ at $x = \rho_m$, therefore equation (12) can be rewriting relatively $\frac{mv_m^2}{2}$ as follows

$$\frac{mv_m^2}{2} = W \cos^2 \alpha + q U_o f_m, \quad f_m = \int_0^{\rho_m} \frac{\partial g(x, \xi)}{\partial \xi} \frac{d\xi}{dx} dx = \int_0^{\rho_m} \text{Ln}(R-x) \xi \xi' d\xi. \quad (13)$$

Substituting (12), (13) into (11), we obtain an integral differential equation of a charged particle motion in the considered HCF (7)

$$(\xi')^2 \left[g_o - g_x + \int_0^x \text{Ln}(R-x) \xi \xi' dx \right] = P^2 \text{Ctg}^2 \alpha_o + f_m - \int_0^x \text{Ln}(R-x) \xi \xi' dx, \quad (14)$$

Where

$$g_o = g(x_m, \xi_m) = \text{Ln}(R) \left[\frac{R^2}{4} + \frac{3}{4} \right] - \frac{R^2}{4} + \frac{1}{4} \quad (15)$$

and $P_o^2 = \frac{W}{qU} \sin^2 \alpha_o$ is a parameter of reflection, relating the geometrical and energy characteristics of mirror.

The integral differential equation (14) has a specific point at $x=0$, because at this case a multiplier $(\xi')^2$ turns to zero, and therefore the equation solution is found in the form of the fractional power series

$$\xi = \sqrt{x} (C_o + C_1 x + C_2 x^2 + C_3 x^3 + C_4 x^4 + C_5 x^5 + C_6 x^6 + \dots). \quad (16)$$

The coefficients C_n , calculated at substitution of fractional- power series (16) into equation (14) are shown below

$$C_o^2 = 4 \frac{P^2 \text{Ctg}(\alpha_o)^2 - f_m}{\gamma}, \quad \gamma = \frac{1}{4} \left(R + \frac{3}{R} - 2R \text{Ln}R \right), \quad (17)$$

$$\frac{C_1}{C_o} = \frac{1}{\gamma} \left[-\frac{C_o^2}{24R} - \frac{3}{8} \text{Ln}R - \frac{11}{16R^2} - \frac{1}{48} \right], \quad (18)$$

$$\frac{C_2}{C_o} = -\frac{9}{10} \frac{C_1^2}{C_o^2} + \frac{1}{\gamma} \left[\frac{C_1}{C_o} \left(-\frac{11 C_o^2}{60 R} - \frac{11}{20} \text{Ln}R - \frac{9}{40R^2} - \frac{3}{40} \right) - \frac{1}{60} \frac{C_o^2}{R^2} - \frac{1}{40R^3} + \frac{13}{120R} \right], \quad (19)$$

$$\frac{C_3}{C_o} = -\frac{15}{7} \frac{C_1 C_2}{C_o^2} + \frac{1}{\gamma} \left[\frac{C_2}{C_o} \left(\frac{11 C_o^2}{56 R} - \frac{13}{28} \text{Ln}R - \right) + \frac{C_1^2}{C_o^2} \left(\frac{5 C_o^2}{16 R} - \frac{17}{56} \text{Ln}R - \right) + \frac{C_1}{C_o} \left(-\frac{5 C_o^2}{56 R} - \frac{3}{28R^3} + \frac{19}{84R} \right) - \frac{C_o^2}{112R^3} - \frac{3}{224R^4} + \frac{17}{672R^2} \right]. \quad (20)$$

Then, all coefficients up to the sixth order on value x have been calculated.

A radial component of trajectory turning point $R = 1 + \rho_m$, needed for calculations of ξ , is determined with help of integral differential equation (14) for the point $x = \rho_m$. In this case

$$(\xi')^2 = \text{Ctg}^2 \alpha_\alpha, \quad g_{x=\rho_m} = 0 \quad \text{and} \quad g_o + f_m = P^2. \quad (21)$$

Substitution g_o from the equation (15) into (21) leads to

$$\text{Ln}R = \frac{4(P^2 - f_m) - R^2 + 1}{3 - R^2}. \quad (22)$$

The quantity R from the expression (22) is determined by the method of successive approximations. As a zero approximation, the cylindrical mirror analyzer's parameters are used

$$R_o = \exp(P^2) = 1 + P^2 + \frac{1}{2}P^4 + \frac{1}{6}P^6 + \frac{1}{24}P^8 + \dots \quad \text{and} \quad f_{m_o} = 0 \quad [3].$$

The sequence of calculations by the method of successive approximations is following: with help of zero approximation the coefficients C_n are determined; from the expression (22) the radial coordinate of trajectory turning point R_1 at the first approximation is found; the coefficients C_n and f_m at the first approximation are calculated; with help of data of the first approximation the quantity R_2 at the second approximation is computed, and etc.

The final results of trajectory's calculation, obtained in the form of the expansion in series on the value of the mirror reflection parameter P up to 14-th order inclusively, have shown below

$$\begin{aligned} \rho_m = & P^2 + \frac{1}{2}P^4 + \left[-\text{Ctg}^2(\alpha_o) + \frac{1}{3} \right] P^6 + \left[-\frac{23}{9}\text{Ctg}^2(\alpha_o) + \frac{3}{8} \right] P^8 + \\ & + \left[\frac{20}{9}\text{Ctg}^4(\alpha_o) - \frac{313}{60}\text{Ctg}^2(\alpha_o) + \frac{53}{120} \right] P^{10} + \\ & + \left[\frac{1007}{90}\text{Ctg}^4(\alpha_o) - \frac{67631}{6300}\text{Ctg}^2(\alpha_o) + \frac{79}{144} \right] P^{12} + \dots \end{aligned} \quad (23)$$

The trajectory projection ξ_m on the mirror axis of symmetry from the point of a particle entering field to the trajectory turning point m is determined by the expression (16) at the condition $x = \rho_m$

$$\xi_m = \xi(x)|_{x=\rho_m} = \sqrt{\rho_m} C_o S, \quad (24)$$

where

$$C_o = \text{Ctg} \alpha_o \sqrt{4P^2 + 4P^4 + 8P^6 + \left(-4\text{Ctg}^2 \alpha_o + \frac{146}{9} \right) P^8 + \left(-\frac{208}{9}\text{Ctg}^2 \alpha_o + \frac{297}{10} \right) P^{10} + \left(\frac{80}{9}\text{Ctg}^4 \alpha_o - \frac{3953}{45}\text{Ctg}^2 \alpha_o + \frac{176737}{3150} \right) P^{12} + \dots}, \quad (25)$$

$$\begin{aligned} S = & \left(1 + \frac{C_1}{C_o} \rho_m + \frac{C_2}{C_o} \rho_m^2 + \frac{C_3}{C_o} \rho_m^3 + \frac{C_4}{C_o} \rho_m^4 + \frac{C_5}{C_o} \rho_m^5 + \frac{C_6}{C_o} \rho_m^6 \right) = 1 - \frac{1}{12}P^2 + \\ & + \left(-\frac{1}{6}\text{Ctg}^2 \alpha_o - \frac{131}{480} \right) P^4 + \left(-\frac{53}{360}\text{Ctg}^2 \alpha_o - \frac{17573}{40320} \right) P^6 + \\ & + \left(0.26389\text{Ctg}^4 \alpha_o + 0.34595\text{Ctg}^2 \alpha_o - 0.50249 \right) P^8 + \\ & + \left(0.81703\text{Ctg}^4 \alpha_o + 1.83040\text{Ctg}^2 \alpha_o - 0.70059 \right) P^{10} + \dots \end{aligned} \quad (26)$$

The total trajectory projection onto the axis of symmetry Z from the source A to its image B is

$$l = \frac{L}{r_o} = \Delta C \operatorname{tg} \alpha_o + 2^* \xi_m, \quad \Delta = \Delta_1 + \Delta_2, \quad (27)$$

where Δ_1 and Δ_2 - the distances of a source and its image from the surface of inner cylindrical electrode.

Conclusions

The trajectories of the charged particles in HCF by the optimally chosen power series segments superposition have been described. The mathematical expression obtained for the trajectories allows calculating of all necessary corpuscular optical parameters of energy analyzers, based on HCF, estimating the abilities of them, and comparing with the existed systems.

References:

1. Zashkvara, V.V. and Tyndyk, N.N. (1996). Potential fields based on circular multipole series. *Nucl. Instr. and Meth.*, A370, 452-460.
2. Zashkvara, V.V., Ashimbaeva, B.U. and Chokin, K.Sh. (2002). Calculation of trajectories in a multipole cylindrical field. *J. of Electron Spectr. and Rel. Phen.*, 122, 195-202.
3. Zashkvara, V.V., Korsunsky, M.I. and Kosmachev, O.S. (1966). The focusing properties of electrostatic mirror with cylinder field. *Zh. Tekh. Phys.*, 1, 132-138. In Russian.