





IRSTI 30.19.33

DOI: <https://doi.org/10.26577/JMMCS.2023.v118.i2.07>

S.K. Akhmediyev<sup>1</sup> , O. Khabidolda<sup>2\*</sup> , N.I. Vatin<sup>3</sup> , G.A. Yessenbayeva<sup>2</sup> ,  
R. Muratkhan<sup>2</sup> 

<sup>1</sup>Abylkas Saginov Karaganda Technical University, Kazakhstan, Karaganda

<sup>2</sup>Karaganda University named after Academician E.A. Buketov, Kazakhstan, Karaganda

<sup>3</sup>Peter the Great St.Petersburg Polytechnic University, Russia, St.Petersburg

\*e-mail: oka-kargtu@mail.ru

## PHYSICAL AND MECHANICAL STATE OF CANTILEVER TRIANGULAR PLATES

In this paper, the bending of cantilever triangular plates at the same angles of inclination of the side edges to the base is investigated. Due to the complexity of the boundary conditions, a numerical finite difference method is applied using a grid of scalene triangles that fits well into the contour of the plate. To solve the problem of an acute angle at the top of the plate, the method of combining the results of calculating a cantilever bar of variable bending stiffness with similar results of calculating a triangular plate supported along the contour using a reduction factor is applied. The results of deflections of the cantilever triangular plate at different angles of inclination of the side edges to the base are given. The theoretical provisions and applied results of this study can be used both in scientific research and in engineering design.

**Key words:** triangular plate, numerical method, grid method, deflection, bending stiffness, rod analogy, reduction factor

С.К. Ахмадиев<sup>1</sup>, Ө. Хабидолда<sup>2\*</sup>, Н.И. Ватин<sup>3</sup>, Г.А. Есенбаева<sup>2</sup>, Р. Муратхан<sup>2</sup>

<sup>1</sup>Ә. Сағынов атындағы Қарағанды техникалық университеті, Қазақстан, Қарағанды қ.

<sup>2</sup>Академик Е.А. Бөкетов атындағы Қарағанды университеті, Қазақстан, Қарағанды қ.

<sup>3</sup>Ұлы Петр Санкт-Петербург политехникалық университеті, Ресей, Санкт-Петербург қ.

\*e-mail: oka-kargtu@mail.ru

### Консолді үшбұрышты пластиналардың физикалық-механикалық күйі

Бұл жұмыста консолді үшбұрышты тақтайшалардың бүйір жиектерінің негізге бірдей көлбеу бұрыштарында қисаюы зерттелді. Шекаралық шарттардың күрделілігіне байланысты пластинаның контурына жақсы сәйкес келетін жан-жақты үшбұрыштардың торын қолдана отырып, ақырлы айырымдардың сандық әдісі қолданылды. Пластинаның жоғарғы жағындағы өткір бұрыш мәселесін шешу үшін қысқару коэффициентін қолдана отырып, пластинаның контуры бойынша үшбұрышты операциямен есептеудің ұқсас нәтижелерімен айналымы іліу қатаңдығының консолді өзектің есептеу нәтижелерін біріктіру әдісі қолданылды. Үшбұрышты бүйір жиектерінің негізге қарай пластиналардың әр түрлі бұрыштарында консольдің ауытқуының нәтижелері келтірілген. Бұл зерттеудің теориялық ережелері мен қолданбалы нәтижелері ғылыми зерттеулерде де, инженерлік жобалауда да қолданыла алады.

**Түйін сөздер:** үшбұрышты тақта, сандық әдіс, тор әдісі, іліу, іліу қатаңдығы, өзек ұқсастығы, редукция коэффициенті.

С.К. Ахмедиев<sup>1</sup>, О. Хабидолда<sup>2\*</sup>, Н.И. Ватин<sup>3</sup>, Г.А. Есенбаева<sup>2</sup>, Р. Муратхан<sup>2</sup>

<sup>1</sup> Карагандинский технический университет имени А. Сағынова, Казахстан, г. Караганда

<sup>2</sup> Карагандинский университет имени академика Е.А. Букетова, Казахстан, г. Караганда

<sup>3</sup> Санкт-Петербургский политехнический университет Петра Великого, Россия, г. Санкт-Петербург

\*e-mail: oka-kargtu@mail.ru

### Обобщенная формула для оценки основного тона консольного стержня с точечными массами

В данной работе исследован изгиб консольных треугольных пластин при одинаковых углах наклона боковых кромок к основанию. Из-за сложности граничных условий применен численный метод конечных разностей с применением сетки из разносторонних треугольников, хорошо вписывающийся в контур пластины. Для решения проблемы острого угла у вершины пластины применен способ совмещения результатов расчета консольного стержня переменной изгибной жесткости с аналогичными результатами расчета треугольной опертой по контуру пластины с использованием коэффициента редукции. Приведены результаты прогибов консольной треугольной пластины при различных углах наклона боковых кромок к основанию. Теоретические положения и прикладные результаты данного исследования могут быть использованы как в научных изысканиях, так и в инженерном проектировании.

**Ключевые слова:** треугольная пластина, численный метод, метод сеток, прогиб, изгибная жесткость, стержневая аналогия, редукционный коэффициент.

## 1 Introduction

Thin triangular plates (two-dimensional mechanical systems) are widely used in various branches of engineering: construction, mechanical engineering, aircraft and shipbuilding, transport, energy, etc., and are also used as bearing elements of a wide variety of structures.

Calculations of triangular plates are widely studied in various works of domestic and foreign scientists [1-3].

At the same time, the calculation of cantilever triangular plates still creates certain technical problems. This is due to the presence of edges free from fastening. And also these technical problems are related to the fact that at the vertex of the triangle a zone of zero bending stiffness is formed, which, with direct calculations, can cause the appearance of displacements in this zone, approaching uncertainty in magnitude (an infinitely large number).

In [4, 5], the bending of elastic isotropic plates in the form of isosceles triangles with different boundary conditions (hinged or rigid edges) is considered. For their calculation, the finite element method with the construction of approximating functions was used, and an example was also given for calculating the bending of a plate in the form of a right-angled triangle with hinged support along the contour.

In the study [6], the static calculation of triangular plates for bending with hinge supported edges by the Ritz method is considered, the corresponding formulas for the analytical determination of the coefficients of the coordinate functions used to perform bending deflections are given, the calculation for bending under the action of concentrated force is performed.

In [7-10], a method of interpolation by the shape coefficient based on affine transformations was proposed for calculating triangular plates with a hinged or rigid support along their perimeter, a bending stress-strain state is considered, including with free vibrations. The plate material can be either isotropic or orthotropic.

In [11], a triangular cantilever plate with a blunted vertex in a viscous hypersonic flow was studied, the sweep of the plate was assumed to be large. The results were obtained by numerical simulation based on the Navier-Stokes equations and Euler equations in combination with approximate methods for calculating heat transfer processes.

In [12], the free vibrations of thin isotropic triangular plates with a central hole with hinged and pinched edges were investigated by the finite element method, and the results obtained were compared with the results of the experimental method (error up to 6%).

In [13], the Chebyshev-Ritz method was applied to free vibrations of multilayer triangular plates based on the analogy with the calculation of a square plate with transformed coordinates under various boundary conditions.

In [14], the bending of triangular plates with point pinches (heterogeneity of boundary conditions) was studied; the Rayleigh-Ritz method was applied based on the general functional of the deformation energy in the presence of an elastic base. In this paper, the problem of local stability of unilaterally pinched triangular plates is investigated.

In [15], a thin triangular plate of arbitrary shape is considered, a numerical method is used for bending free vibrations under various (complex) boundary conditions, including in the presence of internal supports.

Thus, analyzing the content of scientific papers in the field of triangular plates research, it should be noted that with all the variety of types of boundary conditions considered by other authors, many researchers avoid calculations of cantilever triangular plates with an acute "vertex" due to the problem of the "angle" of cantilever plates, and due to the uncertainty of the resolving differential equations in this place. In this regard, the method proposed by the authors of this article for mathematical symbiosis of the results of calculating a cantilever bar of variable bending stiffness with similar results of calculating a modeling triangular plate supported along a contour, based on the reduction factors given, makes it possible to circumvent the problem of an acute "vertex" in cantilever triangular plates and obtain results acceptable from the point of view of calculation accuracy for isosceles triangular plates with an arbitrary angle of the "obliqueness" of the side edges in the state of their flat transverse bending.

The calculation method presented here will also allow solving the vibration problems and the stability problems of cantilever triangular plates in the future.

## 2 Calculation methods

The implementation of the goals set in this study can be achieved by various methods: analytical, numerical, etc.

Numerical methods have the following advantages: the simplicity of the algorithm, obtaining the final results in an accessible (direct) form in the format of numerical values of the desired functions, the achievable accuracy of calculations that meets the requirements of engineering calculations. Therefore, in this paper, an attempt to solve the above problem with an extraordinary (non-standard) approach has been made.

Thus, the object of the proposed study is a cantilever isosceles triangular plate of constant thickness loaded with a uniformly distributed load of intensity "g" (Fig. 1).

As a resolving method, the numerical finite difference method (FDM) is proposed using a combination of two types of regular grids, namely, "linear" and triangular [16, 17].

Figure 2 shows the plate under study, covered with a grid of scalene triangles with a density of  $n=4$  where  $\Delta x = a/4$  is the grid step. The number of calculated nodes is equal to nine ( $i = 0, 1, 2, \dots, 8$ ), taking into account symmetry.

Since when using a triangular grid to calculate a cantilever triangular plate, two lines of nodes outside the contour are captured (by one and two grid steps outside the side edges), we propose the following original approach, which makes it possible to avoid the traditional method of excluding deflections using boundary conditions along the edges of the plate:

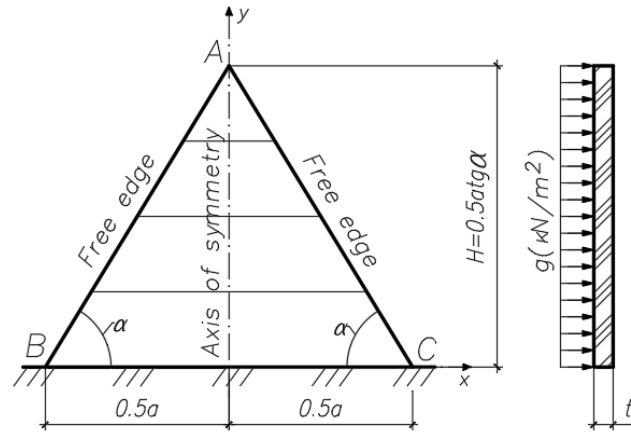

Figure 1: Initial triangular isosceles cantilever plate

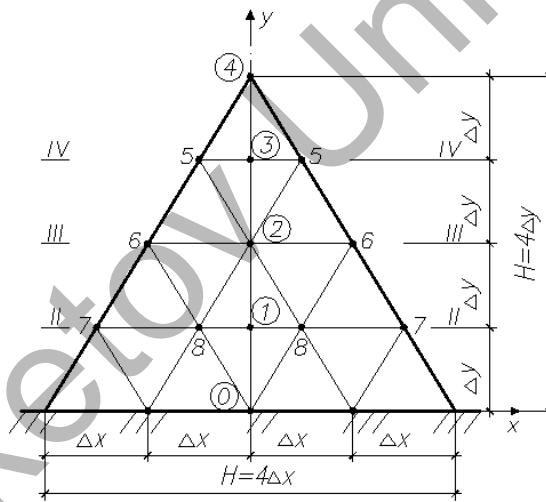

Figure 2: Numbering of calculated nodes of the triangular grid

1) determine separately the deflections in nodes 1, 2, 3 (Fig. 2) in a conditional triangular plate with fixed (freely supported) side edges  $AB$  and  $AC$  (Fig. 1);

2) determine separately the deflections in a conditional cantilever bar of variable bending stiffness with a load uniformly distributed over a triangle (Fig. 3,a);

3) based on the reduction of the results for the deflections of the cantilever bar to the free edges of the triangular cantilever plate, calculate the deflections of the given triangular cantilever plate (Fig. 1, 2) by the combination of the calculation results of the triangular plate fixed along the contour and the cantilever bar with variable bending stiffness.

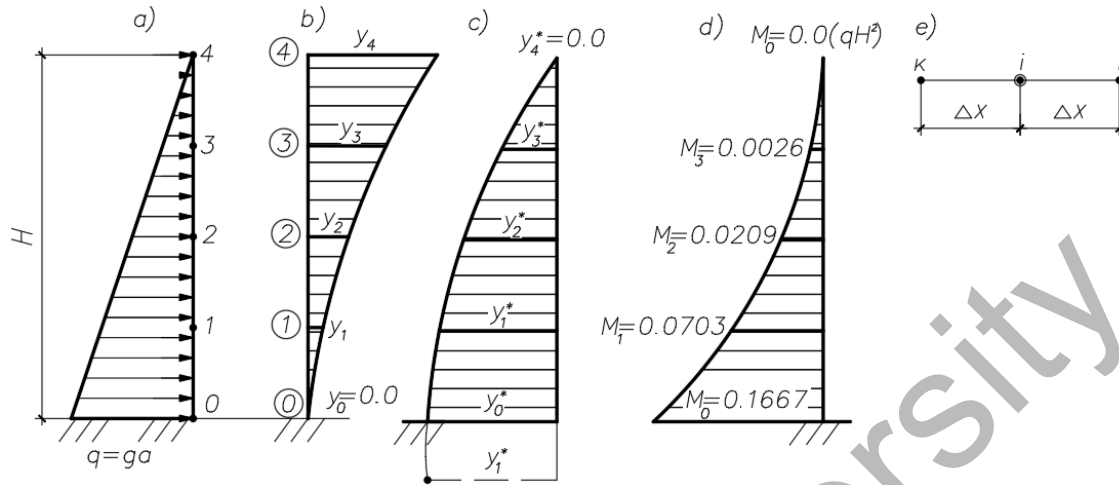

Figure 3: To the calculation of a cantilever bar with variable bending stiffness

### 3 Calculation of the cantilever bar by the finite difference method

The initial differential equation has the form [16-20]

$$EJ_x \frac{\partial^2 y}{dx^2} = M_x. \quad (1)$$

The nodal values of  $M_x$  are obtained from Figure 3,d.

For the  $i$ -th node of a regular "linear" grid (Fig. 3,e), equation (1) takes the form ( $\lambda = \Delta x = 0.25H$ )

$$y_e - 2y_i + y_k = \frac{M_i \lambda^2}{EJ_i}. \quad (2)$$

In order to not include the first and second nodes outside the contour in the resolving finite-difference equations when writing in the node "4" (Fig. 3,b), instead of the initial scheme (Fig. 3,b), we apply a new scheme (Fig. 3,c), in which the node "4" is conditionally fixed from displacement, and the node "0" (the place of rigid fixing) is conditionally released. In this case, other displacements  $y_i^*$  (0, 1, 2, 3) (Fig. 3,c) will appear instead of the original displacements of nodes  $y_i$  ( $i = 0, 1, 2, 3, 4$ ) (Fig. 3,b).

After finding the displacements  $y_i^*$ , the real displacements  $y_i$  are determined by the following reduction formula

$$y_i = y_0^* - y_i^* \quad (i = 1, 2, 3, 4). \quad (3)$$

Writing resolving finite-difference equations for all calculation nodes 0, 1, 2, 3 (Fig. 3,c)

according to type (2), we obtain a system of linear algebraic equations, which has the form

$$\begin{cases} -y_0^* + y_1^* = (0.01389) \frac{qH^4}{EJ_0}; \\ y_0^* - 2y_1^* + y_2^* = (0.00586) \frac{qH^4}{EJ_0} \\ y_1^* - 2y_2^* + y_3^* = (0.0026) \frac{qH^4}{EJ_0} \\ y_2^* - 2y_3^* = (0.00065) \frac{qH^4}{EJ_0} \end{cases} \quad (4)$$

The solving of the system of linear algebraic equations (4) gives the following results

$$\begin{aligned} y_0^* &= (0.100) \frac{qH^4}{EJ_0}; & y_1^* &= (0.0879) \frac{qH^4}{EJ_0}; \\ y_2^* &= (0.625) \frac{qH^4}{EJ_0}; & y_3^* &= (0.0332) \frac{qH^4}{EJ_0}. \end{aligned} \quad (5)$$

According to the formula (3), based on the results obtained (5), the real nodal displacements (deflections) of the cantilever bar are determined (Fig. 1,b)

$$\begin{aligned} y_0 &= 0.00; & y_1 &= (0.0121) \frac{qH^4}{EJ_0}; & y_2 &= (0.0375) \frac{qH^4}{EJ_0}; \\ y_3 &= (0.0668) \frac{qH^4}{EJ_0}; & y_4 &= (0.079) \frac{qH^4}{EJ_0}. \end{aligned} \quad (6)$$

To assess the reliability of the above results (6), the calculation of this cantilever beam (Fig. 3,a) was performed by the method of initial parameters, while the ratio  $y_{\max} = y_4 = \frac{qH^3}{30 \cdot (EJ_0 \cdot 0.44)} = 0.076 \frac{qH^4}{EJ_0}$  was obtained. Comparison with the result (6) gives a deviation (error)  $\delta = 4\%$ , which is within the limits of engineering accuracy.

#### 4 Results of deflections for a triangular plate with edges supported along the perimeter

We consider an equilateral triangular plate with freely supported (hinged) edges  $AB$ ,  $AC$  and a rigidly pinched base (edge  $BC$ ) under the action of a load uniformly distributed over the surface with intensity "g"(Fig. 4).

The results of the calculation of such a plate for bending by *FDM* with the use of a triangular grid are given in the manual [19]. In nodes 2, 8 we have the following values of deflections

$$f_2 = (3.709 \cdot 10^{-4}) \frac{ga^4}{D}; \quad f_8 = (2.919 \cdot 10^{-4}) \frac{ga^4}{D}, \quad (7)$$

where  $D = \frac{Et^3}{[12(1-\nu^2)]}$  is the cylindrical stiffness of the plate.

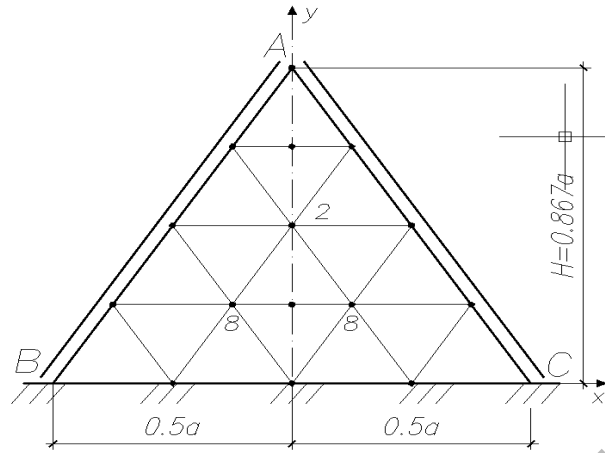

Figure 4: Contour-supported triangular plate

## 5 Calculation results for bending of a cantilever triangular plate

In order to determine the final results of the bending calculation (values of deflections in the grid nodes) of the cantilever triangular plate (Fig. 2), it is necessary to combine the calculation results of the cantilever bar (6) and the triangular plate (7) supported along the contour. In this case, the obtained results (6) should be reduced (combined) with the results (7).

The reduction factor ( $k = 0.16342$ ) is obtained based on a comparison of the values for the bending stiffness of the bar ( $EJ_0 = Eat^3/12$ ) and for the cylindrical stiffness of the plate  $D = \frac{Et^3}{[12(1-\nu^2)]}$ , that is, instead of the data (6), the following data are obtained.

$$\begin{aligned}
 y_0^0 &= 0.0; & y_1^0 &= 0.16342 \cdot y_1 = (0.00198) \frac{qH^4}{D}; \\
 y_2^0 &= 0.16342 \cdot y_2 = (0.00613) \frac{qH^4}{D}; \\
 y_3^0 &= 0.16342 \cdot y_3 = (0.0109) \frac{qH^4}{D}; \\
 y_4^0 &= 0.16342 \cdot y_4 = (0.00163) \frac{qH^4}{D}.
 \end{aligned} \tag{8}$$

Deflections in the remaining nodes (outside the vertical axis of symmetry at nodes 0-1-2-3-4) are determined by a combination of the results (7), (8) (Fig. 5) according to the formula

$$\left( W_{i_0}^{\text{left}} = W_{i_0}^{\text{right}} \right) = y_{i_0} + f_{i_0} \tag{9}$$

For example, along the line IV-IV, where nodes 5-3-5 are located (Fig. 2) ( $i_0=5$ ), we have

$$W_5 = y_3 + f_3 = \frac{qa^4}{D} (0.0109 + 0.000198) = 0.0111 \frac{qa^4}{D}.$$

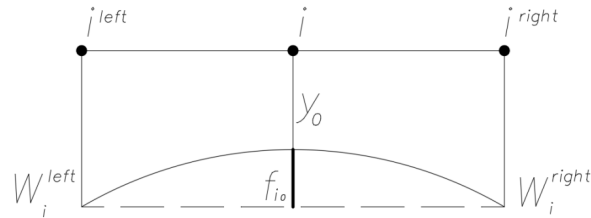

Figure 5: Towards connection of the plate and rod deflections

In the same way, we calculate deflections in other grid nodes of the cantilever triangular equilateral plate (Fig. 2). The results of these calculations are presented in Table 1.

Table 1

$W_i \frac{qa^4}{D}$	Grid nodes (fig. 2)							
	1	2	3	4	5	6	7	8
	0.00196	0.00613	0.0109	0.0163	0.0111	0.00792	0.008	0.00275

Based on this technique, the following study was performed: in Table 2, the values of deflections in some nodes of the cantilever triangular plate (Fig. 2) are given depending on the ratio  $H/a$  or on the angle  $\alpha$  at the base of the plate.

Table 2

$H/a, (\alpha)$	$W_i \frac{D}{qa^4}$		
	$i=2$	$i=4$	$i=6$
0.5 ( $45^0$ )	0.00352	0.00937	0.00455
0.87 ( $60^0$ )	0.00613	0.0163	0.00792
1.0 ( $63^024'$ )	0.00705	0.0188	0.00911
1.5 ( $71^036'$ )	0.01057	0.0281	0.01365
2.0 ( $76^0$ )	0.0141	0.0375	0.01821

According to Table 2, graphical dependencies  $u_i = f(H/a)$  are plotted (Fig. 6).

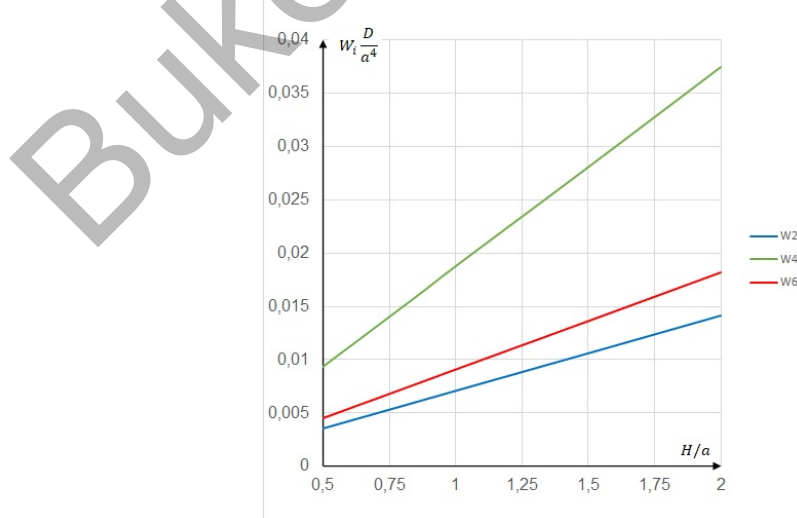
Figure 6: Dependence of deflections on the ratio  $H/a$  or on the angle  $\alpha$

## 6 Discussion

Thus, the application of the finite difference method in this paper using a grid of scalene triangles made it possible to solve the problem of calculating cantilever triangular plates, which consists in the fact that it is difficult to mathematically describe the desired deflection function at the vertex of the triangle (node A, Fig. 1). We found a way to get around this problem by symbiotic combining the calculation results of a triangular plate supported along a contour and the calculation results of a single-span bar based on the use of a reduction factor that provides the transition from the simulation (conditional) model to the original model of cantilever triangular plate.

## 7 Conclusions

1. In this paper, the study of the bending state for a cantilever isosceles triangular plate is performed. The numerical method of finite differences was chosen as the resolving method.

2. An original method is proposed to exclude deflections of the nodes outside the contour for a triangular network from the calculation. This allows solving the problem of the zone uncertainty near the triangle vertex. Until today, this problem is relevant, which makes it necessary to calculate the cantilever triangular plates for bending, stability and vibrations. The method proposed in this paper consists in combining the results of calculating a cantilever bar of variable cross section with the results of calculating a triangular plate freely supported along the contour. At the same time, a method of transition from the results of the rod model to a two-dimensional structure (plate) through the reduction factor is found.

3. The study of the values of individual deflections for the cantilever triangular plate depending on the variable parameter  $H/a$  (see the graph in Fig. 6) was made. At the same time, it was determined that with an increase in the value of  $H/a$ , the deflection at the end of the console (node 4) increases significantly (nonlinearly), while the deflections at nodes 2, 6 increase only linearly.

## References

- [1] Bosakov S.V., Skachek P.D. Static calculation of triangular plates with hinged sides. *Mechanics. Research and innovation*, 2017, No. 10, pp. 24 - 28.
- [2] Akhmediev S.K., Zhakibekov M.E., Kurokhtina I.N. Nuguzhinov Zh.S. Numerical study of the stress-strain state of structures such as thin triangular plates and plates of medium thickness. *Structural mechanics and calculation of structures*, 2015, No. 2 (259), pp. 28 - 33.
- [3] Bosakov S.V., Skachek P.D. Application of the Ritz method in the calculations of triangular plates with different conditions of fastening to the action of a static load. *Structural mechanics and calculation of structures*, 2018, No. 5 (280), pp. 17 - 23.
- [4] Korobko A.V., Kalashnikova N.G., Abashin E.G. Transverse bending and free vibrations of elastic isotropic plates in the form of isosceles triangles. *Construction and reconstruction*, 2021, No. 6, pp. 20 - 27. <https://doi.org/10.33979/2073-7416-2021-98-6-20-27>
- [5] Korobko A.V., Chernyaev A.A., Shlyakhov S.V. Application of the MICF method for calculating triangular and quadrangular plates using widely known geometric parameters. *Construction and reconstruction*, 2016, No. 4, pp. 19 - 28.
- [6] Saliba H.T. Triangular elements and the superposition techniques in till free vibration analysis of plates. *Mecanique industrielle et materiaux (11th Colloquium on Vibrations, Shocks and Noise)*, 1996, No. 49 (4), pp. 168 - 170.

- [7] Korobko A.V. Calculation of triangular plates by interpolation method by the shape coefficient using affine transformations. News of higher educational institutions. Aviation technology, 2003, No. 2, pp. 13 - 16.
- [8] Korobko V.I., Savin S.Yu. Free vibrations of triangular orthotropic plates with homogeneous and combined boundary conditions. Construction and reconstruction, 2013, No. 2, pp. 33 - 40.
- [9] Korobko V.I., Savin S.Yu., Boyarkina S.V. Bending of triangular orthotropic plates with homogeneous and combined boundary conditions. Construction and Reconstruction, 2012, No. 1, pp. 7 - 13.
- [10] Muromsky A.S., Korobko A.V. Calculation of triangular plates using affine transformations. Proceedings of the 55th International scientific and technical conference of young scientists (doctoral students, postgraduates and students) "Actual problems of modern construction St. Petersburg, 2001.
- [11] Vlasov V.I., Gorshkov A.B., Kovalev R.V., Lunev V.V. Thin triangular plate with a blunted vertex in a viscous hypersonic flow. 2009, No. 4, pp. 134 - 145.
- [12] Grigorenko O.Y., Borisenko M.Y., Boichuk O.V. et al. Free vibrations of triangular plates with a hole\*. Int Appl Mech., 2021, No. 57, pp. 534 - 542. <https://doi.org/10.1007/s10778-021-01104-3>.
- [13] Dongze He, Tao Liu, Bin Qin, Qingshan Wang, Zhanyu Zhai, Dongyan Shi. In-plane modal studies of arbitrary laminated triangular plates with elastic boundary constraints by the Chebyshev-Ritz approach. Composite Structures, 2021. DOI: 10.1016/j.compstruct.2021.114138.
- [14] Iman Dayyani, Masih Moore, Alireza Shahidi. Unilateral buckling of point-restrained triangular plates. Thin-Walled Structures, 2013, Vol. 66, pp 1 - 8.
- [15] Cai D., Wang X., Zhou G. Static and free vibration analysis of thin arbitrary-shaped triangular plates under various boundary and internal supports, Thin-Walled Structures, 2021, Vol. 162, No. 107592.
- [16] Varvak P.M., Varvak L.P. Method of grids in problems of calculation for building structures. Moscow, Stroyizdat, 1977, 154 p.
- [17] Karamansky T.D. Numerical methods of structural mechanics. Moscow, Stroyizdat, 1980, 434 p.
- [18] Akhmediev S.K. Analytical and numerical methods for calculating machine-building and transport constructions and structures (textbook). Karaganda, KarTU, 2016, 158 p.
- [19] Akhmediev S.K. Calculations of triangular plates. Karaganda, KarTU, 2006, 86 p.
- [20] Nuguzhinov Z.S., Akhmediyev S.K., Donenbayev B.S., Kurokhtin A.Yu., Khabidolda O. Comparative analysis of designing wall panels with hole based on one-dimensional and two-dimensional computer models. IOP Conf. Series: Materials Science and Engineering, 2018, 456 012082. DOI:10.1088/1757-899X/456/1/012082
- [21] Kasimov A.T., Yessenbayeva G.A., Zholmagambetov S.R., Khabidolda O. Investigation of layered orthotropic structures based on one modified refined bending theory. Eurasian Physical Technical Journal, 2021, Vol.18, No. 4(38), pp. 37 - 44. DOI 10.31489/2021No4/37-44