

UDC 44.35.31

INVESTIGATION OF THE MAIN CHARACTERISTICS  
OF THE STRAIGHT FLOW HYDRO TURBINE

Kazakbay G.B., Turalina D.E.

Farabi Kazakh National University, Faculty of Mechanics and Mathematics, 050040,  
Al-Farabi 71, Almaty, Kazakhstan, ggauharkb@gmail.com

*In this paper the results of the research conducted with the aim to determine the effective version of hydro wheel blades of straight flow hydro turbine are presented. The increasing of energy efficiency of hydro turbine is directly related to the configuration of blades. Investigation is performed in the COMSOL Multiphysics application program with numerical method. Navier-Stokes equations describe motion of water flow. Numerical research of flow is performed using Reynolds Averaged Navier-Stokes method. The optimal attack angle of water on hydro turbine blades is determined, optimal location of the blades, changing of velocity and pressure distribution of water through hydro turbine blades are investigated. Lift and drag forces, coefficients acting on the blades are defined. Based on the results of the research, the optimal configurations of the hydro turbine blades with high energy efficiency are determined.*

**Keywords:** hydro turbine, blade, COMSOL Multiphysics, lift force, drag force, lift coefficient, drag coefficient.

## Introduction

Scientific research work is related to improving the energy efficiency of hydro turbine by changing the stream flow to hydro wheel. Hydropower plants use energy of water flow as the source of energy. Hydro turbine is the hydro engine that turn coming flow energy to mechanical energy.

Today, the whole world pays great attention to water flow energy as the effective source of energy. Investigated hydro turbine for small hydroelectric power station does not require a dam. Instead, it works in scheme as a part of the water given to head tube, after flowing through hydro turbine again dumped into the river. This straight flow hydro turbine size is small, so to construct it need less material accordingly it cost cheaper.

It is significant to correctly choosing of the structure of the turbine, the size and location of the blades, the parameters of the guide vane, the head of water, the structure of the hydro wheels when installing a hydro turbine on a water stream to generating sufficient energy and effective working. Scientific research working is aimed to improving low head hydro turbine efficiency by changing the stream flow to hydro wheel. The optimal version of the attack angle on guide vane and hydro wheel blades is for improving efficiency of hydro turbine. Investigated low head hydro turbine can be used in the small and medium rivers of the Central Asian countries and Kazakhstan. This low head hydro turbine for small hydroelectric power station is for using for seasonal agriculture to farmers and for using in small settlements and remote villages [1, 2].

## 1. Computational experiment

The method of research is a numerical experiment. A theoretical study was carried out, a mathematical model of a hydro turbine blade was performed in the COMSOL Multiphysics application package. The COMSOL Multiphysics examines the distribution of velocity and pressure of water along the turbine blades [3]. External construction of 3D model of hydro turbine in the interactive of COMSOL Multiphysics application package is shown in Figure 1.

Water enters through inlet tube, guide vane, rotating hydro wheel and pass through turbine then exit through outlet tube.

To take more energy is needed to rotate the hydro wheel as more. Therefore, there is a guide vane with the aim to regulate impact and direction of water flow to the hydro wheel blades. When water flow through hydro turbine passing through guide vane and hit blades with pressure, then they rotate [4, 5].

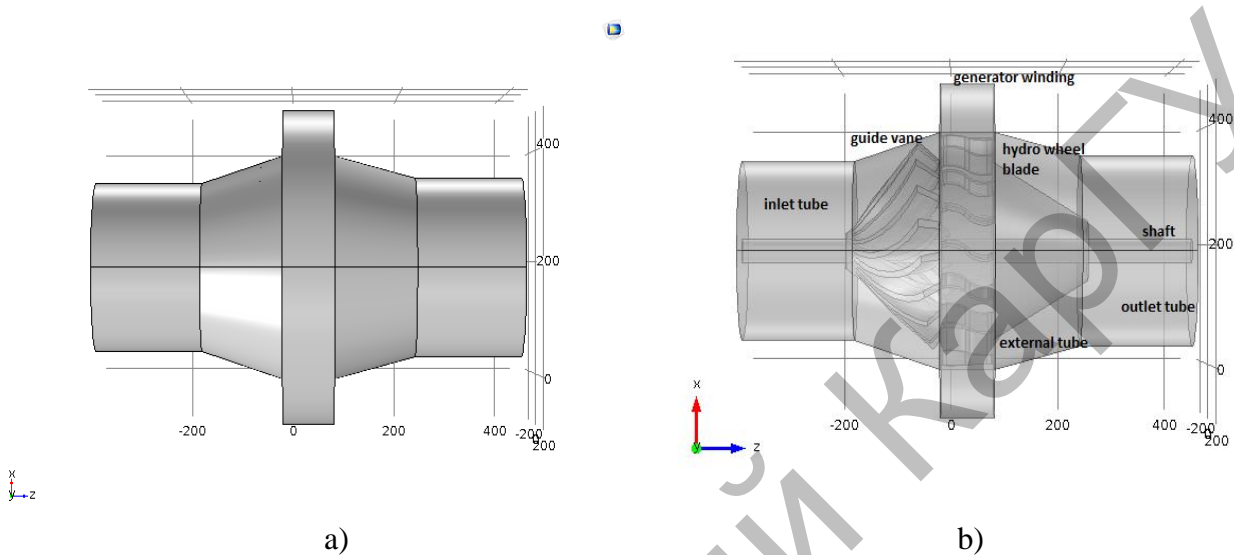

**Fig.1.** Model of hydro turbine: a) external construction, b) internal construction.

Guide vane and hydro wheel of the hydro turbine are shown in Figure 2. Front part as cone, blade located at part as cylinder.

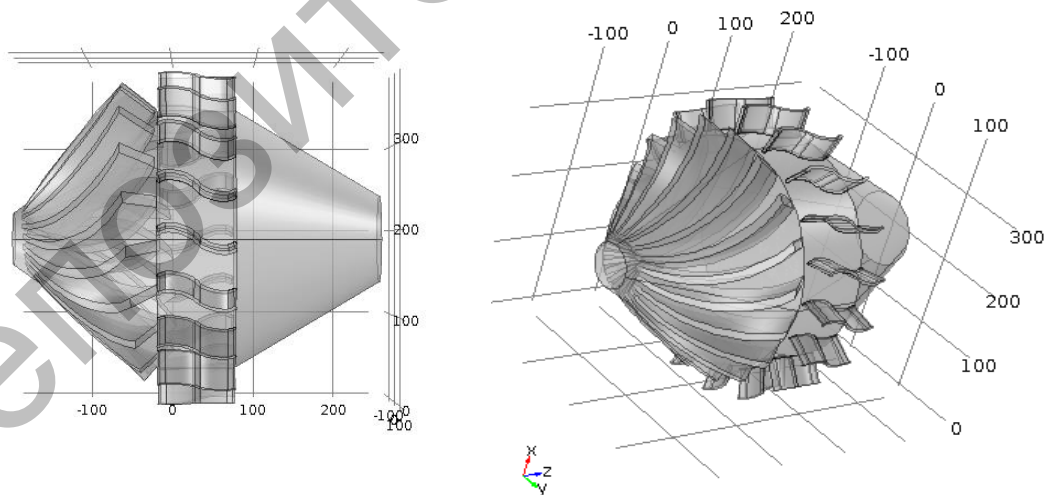

**Fig.2.** Guide vane and hydro wheel.

The energy efficiency of the hydro turbine is influenced by the number, shape, location, and attack angle of the guide vane and blades [6]. Therefore, the results of the research of the attack angle to the hydro wheel blades are presented. Attack angle is the angle between coming flow direction and chord line of the blade. Research was conducted with the purpose of improving the energy efficiency of hydro turbine.

Numerical calculation was performed by COMSOL Multiphysics application package. The results were obtained by changing the attack angle of water flow on blades of hydro wheel in two dimensional domain. Three different angles were obtained to show the improving in energy efficiency and to compare. The distribution of velocity and pressure of water flow in COMSOL Multiphysics application package during 10 seconds was analyzed, with suggesting that the initial velocity 1 m/sec.

Distribution of water flow velocity and pressure was calculated with using Reynolds Averaged Navier Stokes (RANS) method to Navier-Stokes equation for incompressible fluid. For incompressible fluid the Navier-Stokes equations consists of motion and continuity equations [7]:

$$\rho \frac{\partial u}{\partial t} + \rho(u \cdot \nabla)u = \nabla \cdot [-pI + (\mu + \mu_r)(\nabla u + (\nabla u)^T)] + F$$

$$\rho \nabla \cdot (u) = 0 \quad , \quad (1)$$

where  $u$  is the fluid flow velocity,  $\rho$  is the fluid density,  $p$  is the fluid pressure,  $\mu$  is the fluid dynamic viscosity,  $\nabla$  is nabla operator,  $I$  is the identity matrix,  $T$  is stress tensor,  $F$  is the applied body force on the fluid.

## 2. Computational experiment Defining optimal attack angle of the blades

There are two ways to changing the attack angle of the model. It is possible to turn the blade itself or to fixed the blade but change the flow direction at the inlet. Second way is more simple to adjust the velocity field at the inlet boundary condition and there is no need to remesh the model for every attack angle. Scheme of attack angle on the hydro wheel blade  $\alpha$  is illustrated in Figure 3.

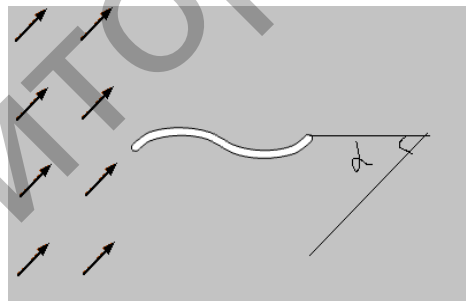

Fig.3. Attack angle.

In Figure 3 arrows show the direction of the flow velocity. There  $\alpha$  means attack angle. Attack angle is the angle between coming flow direction and chord line of the blade. The initial velocity of the water flow are determined as  $U \cdot \cos(\alpha \cdot \pi / 180)$  in x direction and as  $U \cdot \sin(\alpha \cdot \pi / 180)$  in y direction. Here  $U = 1$  m/s. Considered three various location of blades with changing the attack angle [8]. Values of attack angle  $\alpha$  are  $40^\circ$ ,  $45^\circ$ ,  $60^\circ$ .

Results of velocity changing and pressure distribution along blade changing the attack angle during 10 second are demonstrated in Figure 4.

Changing of colour from blue to red shows the increasing of velocity and pressure. Arrows show water flow direction. In the first case the maximum value of velocity is reached to 1.32 m/s and pressure 565 Pa. Pressure increase in the bottom side of the blade as a result of the appearing the lift force. Changing attack angle to  $45^\circ$  the maximum value of velocity is reached to 1.31 m/s and maximum value of pressure is reached to 587 Pa. So we see that the attack angle has affect.

Changing attack angle to 60° angle degree the maximum value of velocity is reached to 1.26 m/s and pressure is reached to 595 Pa. Changing the attack angle is affected to previous results.

Results of numerical experiment by COMSOL Multiphysics of the changing of velocity and pressure distribution of flow with changing attack angle of the blades are shown in Table 1.

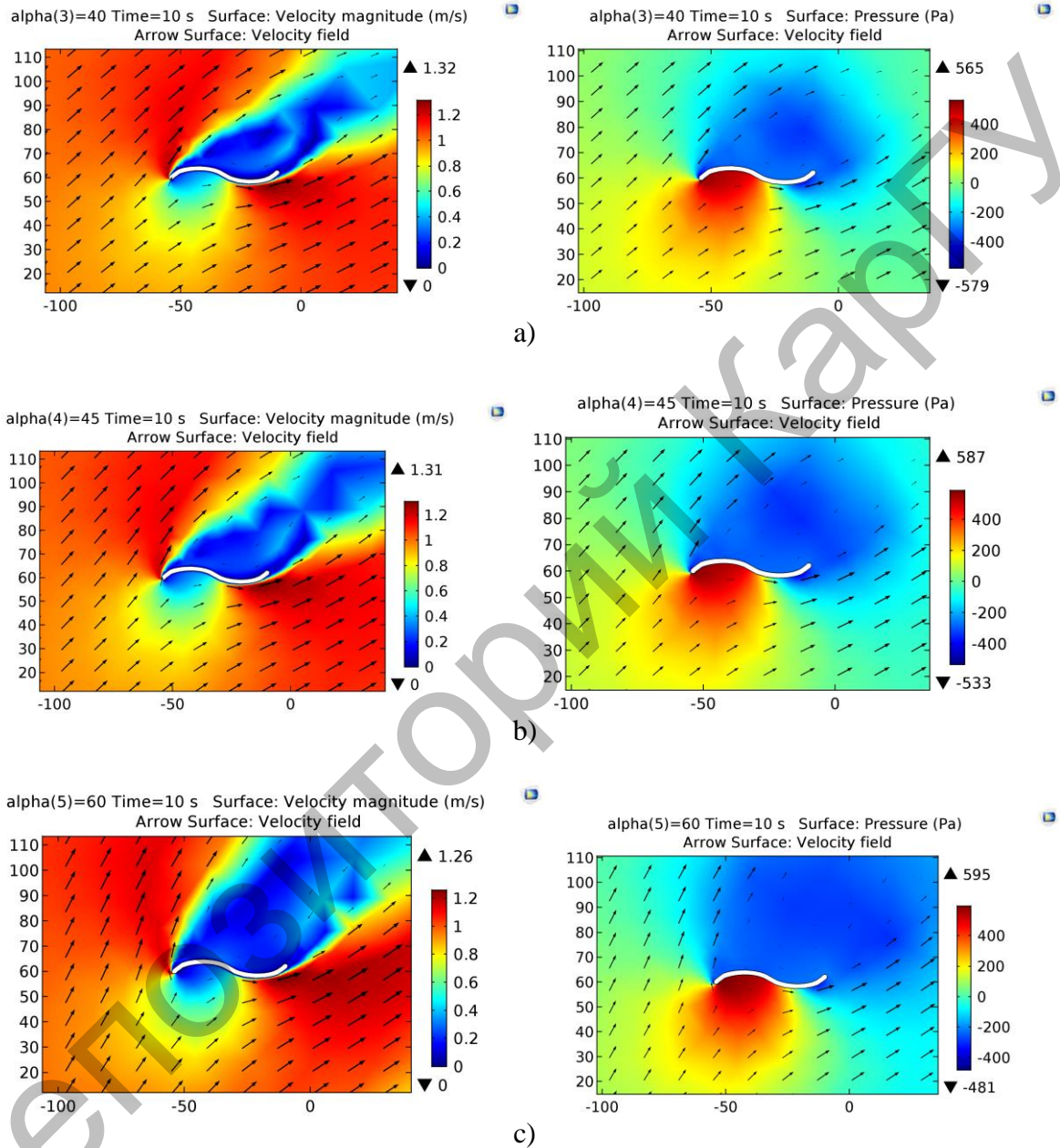

Fig.4. Distribution of velocity and pressure at different attack angle: a) 40°, b) 45°, c) 60°.

Table 1. Velocity and pressure changing with changing attack angle

Name	Attack angle of flow, degree	Maximum value of velocity of flow, m/s	Maximum value of pressure of flow, Pa
1	40	1.32	565
2	45	1.31	587
3	60	1.26	595

In version when attack angle  $40^\circ$  the maximum value of velocity is reached. Maximum value of pressure is reached when attack angle  $60^\circ$ .

### 3. Defining lift and drag forces

When fluid flow passes a body, it exerts a force on the surface. The force component that perpendicular to the flow direction is called lift force  $F_L$ . The force component that parallel to the flow direction is called drag force  $F_D$  [9]. There are two distinct contributors to lift and drag forces — pressure force and viscous force. The pressure force is the force appearing due to the pressure difference across the surface. The viscous force is the force deriving from friction that acts in the opposite direction of the flow.

The lift and drag forces at different angle attack of the blade at tenth second is shown in Fig. 5. Was chosen as various angle attack as  $0^\circ$ ,  $15^\circ$ ,  $40^\circ$ ,  $45^\circ$ ,  $60^\circ$ ,  $90^\circ$ .

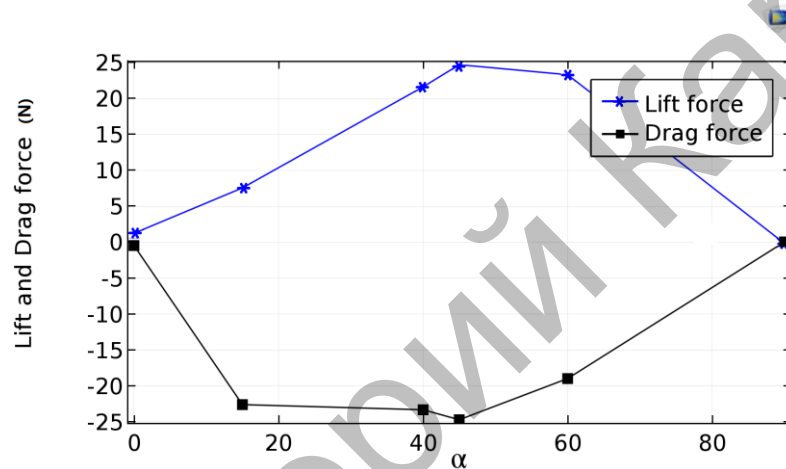

Fig.5. Lift force and drag force at tenth second.

The values of the drag force are decreasing from 0 angle degrees to 45 angle degrees, then values are increasing. The lift force values are increasing from 0 to 45 angle degrees, then started to decreasing. So at 45 angle degree the lift force takes maximum value and the drag force takes minimum value.

### 4. Defining lift and drag coefficients

Lift coefficient is defined as:

$$C_L = \frac{F_L}{\frac{1}{2} \rho U^2 c} \quad (2)$$

Drag coefficient is defined as:

$$C_D = \frac{F_D}{\frac{1}{2} \rho U^2 c} \quad (3)$$

Here  $C_L$  is the dimensionless lift coefficient,  $C_D$  is the dimensionless drag coefficient,  $U$  is the mean velocity,  $c$  is the blade length.

In Figure 6 showed calculation results of lift and drag coefficients at different angle attack. Drag coefficient magnitudes are decreasing from 0 angle degrees to 45 angle degrees, then started to increasing. Lift coefficient magnitudes are increasing from 0 to 45 angle degrees, then it is decreasing. So at 45 angle degree the lift coefficient takes maximum value and the drag coefficient takes minimum value.

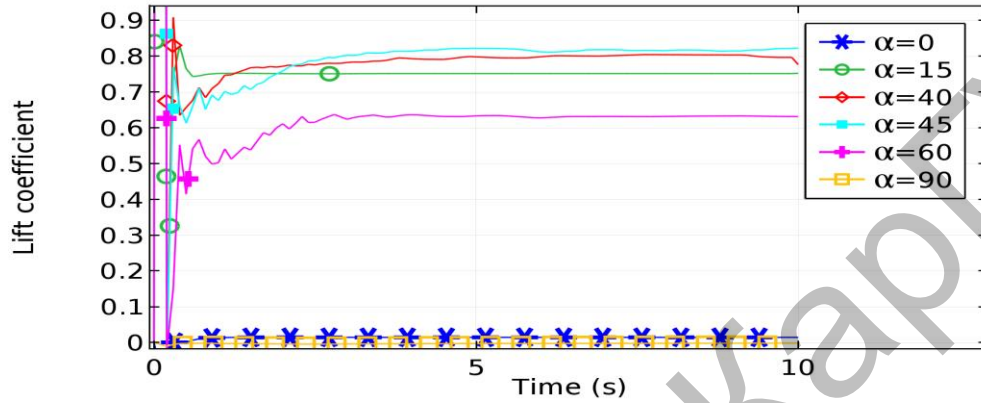

a)

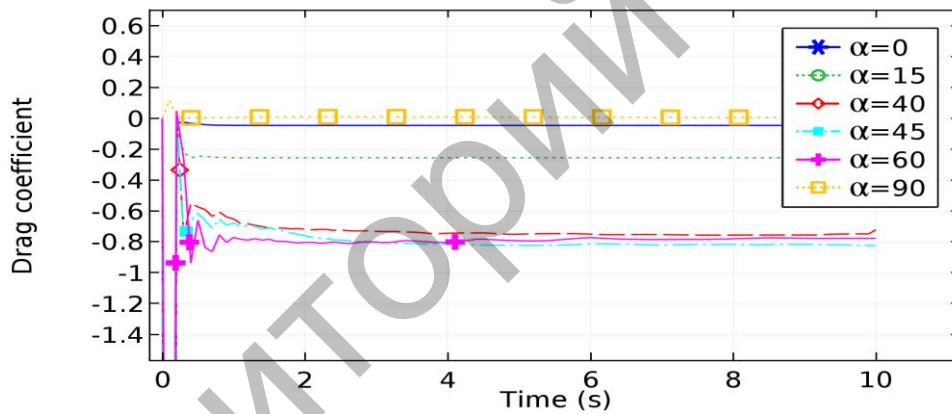

b)

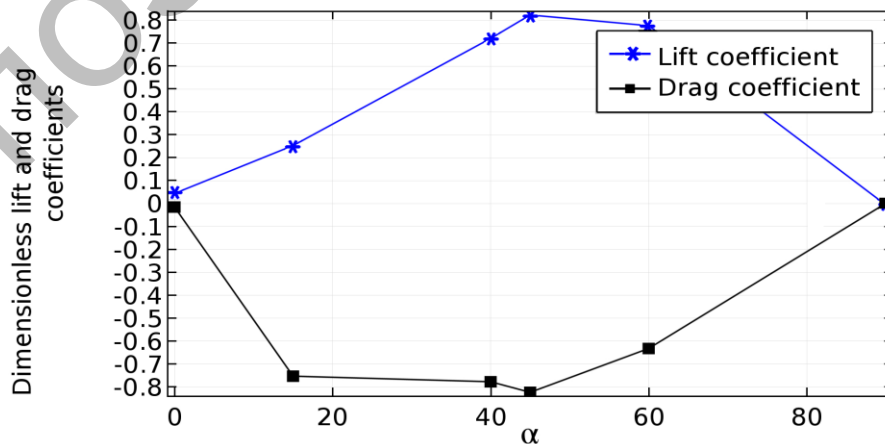

c)

**Fig. 6.** Lift and drag coefficients: a) Lift coefficient during ten seconds, b) drag coefficient during ten seconds, c) lift and drag coefficients at tenth second.

## Conclusion

The effective version of hydro wheel blades of straight flow hydro turbine was determined. Research with the aim of improving efficiency of low head hydro turbine was performed. Three various locations of the blades with changing attack angle were investigated in the COMSOL Multiphysics application package. Based on the results of the research, it was determined the optimal configurations of the hydro wheel blades of the hydro turbine. As optimal configuration was chosen hydro wheel blade with the attack angle 45 angle degrees, where maximum value of velocity reached to 1.31 m/s and maximum value of pressure reached to 587 Pa. The lift and drag forces, lift and drag coefficients at different attack angle were defined. Maximum value of lift force and coefficient, minimum value of drag force and coefficient were defined and was taken 45 angle degree as optimal at attack angle.

## REFERENCES

- 1 Koshumbayev M., Yerzhan A. The innovative design of free-flow hydraulic turbine small hpp. *Proceeding of the 2<sup>nd</sup> International conference on Innovative trends in multidisplinary academic research*, Istanbul, Turkey, 2015, pp.55.
- 2 Turalina D. E., Bossinov D. Zh. Theoretical and experimental investigations to define optimal parameters of straight-flow turbine for non-dam hydro power station. *KazNU Bulletin. Series Mathematics, Mechanics, Informatics*, 2015, Vol. 84, pp. 124 – 131.
- 3 COMSOL Multiphysics *User's Guide*. 2012, 1292 p.
- 4 Bystritskiy G.F., Gasangadzhiev G.G., Kozhichenkov V.S. *Obshchaya energetika. Proizvodstvo teplovoiy i elektricheskoy energii*: Uchebnik. 2017, Moscow, Knorus, 410 p. [in Russian]
- 5 Stesina S.P. *Gidravlika, gidromashini i gidropnevmoпривод*: Ucheb. posobie dlya vyzov. 2007, Moscow, Akademiya, 336 p. [in Russian]
- 6 Bashta T.M., Rydnev S.S., Nekrasov B.B. *Gidravlika, gidromashini i gidroприводи*: Ycheb. dlya vyzov. 2010, Moscow, Alyans, 423 p. [in Russian]
- 7 Loytsyanskii L.G. *Mechanics of liquids and gases*. 1987, Moscow, Science, 840 p. [in Russian]
- 8 Kazakbay G.B., Turalina D.E. Research of the influence of lift force in accordance with the attack angle of water flow on the hydro wheel blades. *Proceeding of the V International Farabi readings. International scientific conference of students and young scientist*, Almaty, Kazakhstan, 2018, pp.60.
- 9 [Peter Lyu](http://www.comsol.com/blogs/how-do-i-compute-lift-and-drag). How Do I Compute Lift and Drag. Available at: <http://www.comsol.com/blogs/how-do-i-compute-lift-and-drag>