



Received: 11/10/2023

Revised: 08/02/2024

Accepted: 27/02/2024

Published online: 29/03/2024

Research Article



Open Access under the CC BY -NC-ND 4.0 license

UDC: 538.953; 621.039.587

## ANALYSIS OF METHODS FOR SIMULATING THE DECAY HEAT IN CORIUM WHEN MODELING A SEVERE ACCIDENTS AT NUCLEAR POWER PLANT

Skakov M.K.<sup>1</sup>, Baklanov V.V.<sup>2</sup>, Nurpairova G.S.<sup>2,3\*</sup>, Akaev A.S.<sup>2</sup>,  
Bekmuldin M.K.<sup>2</sup>, Toleubekov K.O.<sup>2</sup>

<sup>1</sup>National Nuclear Center of the Republic of Kazakhstan, Kurchatov, Kazakhstan

<sup>2</sup>Institute of Atomic Energy of the National Nuclear Center of the Republic of Kazakhstan, Kurchatov, Kazakhstan

<sup>3</sup>Shakarim University, Semey, Kazakhstan

\*Corresponding author: [nurpairova@nnc.kz](mailto:nurpairova@nnc.kz)

**Abstract.** It is known that during development of a severe accident at a nuclear power plant, the melting of core materials and the formation of corium occurs. A feature of corium is the presence of a decay heat, which contributes a lot to the nature of its interaction with the structural materials of the reactor facility. In this regard, quite serious requirements are imposed on methods for simulating decay heat in the corium prototype, which relate to both the uniformity of the volume distribution and its intensity. This paper presents a comparative analysis of existing methods for decay heat simulation in corium, which are used at various experimental facilities investigating the operation of passive protection systems in severe accidents with reactor meltdown at nuclear power plants. By comparing the advantages and disadvantages, a more practical method of decay heat simulation is determined and ways are proposed to further improve the chosen method to fully simulate the thermal field of a real corium.

**Keywords:** nuclear power plant, severe accident, corium, decay heat, simulation

### 1. Introduction

One of the main directions of the development of nuclear energy safety is the research of the final stage of a severe accident at a nuclear power plant (NPP) with core meltdown. During the melting of the reactor core, the so-called corium is formed - a melt of a radioactive mixture of uranium oxide, zirconium, zirconium oxides and steel components (products of high-temperature interaction of metals with an oxidizing medium) and other structural elements [1]. A special feature of corium is a large amount of stored energy and the presence of residual energy release due to the fact that the nuclear fuel contained in the corium continues to be a source of heat released due to the decay reactions of fission fragments of <sup>235</sup>U nuclei accumulated during the operation of the reactor, which allows the melt to remain in a liquid state for a long time and melt the reactor structure with its subsequent release down to the ground and groundwater [2-3].

The contribution of residual energy release to the thermal state of the corium was noted in [4]. This work examines the influence of the accuracy of determining the residual energy release during neutronics calculations on the results of thermal calculations. Analysis of the results shows that the amount of power of the residual energy release affects the value of the maximum temperature. Thus, it was found that a change in the power of the residual energy release by 5% leads to a significant change in the temperature field,

which in turn affects the nature of the interaction of the corium with various structural elements. In this regard, it is obvious that in order to ensure physical modeling conditions that are as close as possible to full-scale ones, it is necessary to take into account not only the correspondence of the composition of the corium prototype to the real one, but also the amount of energy release in the melt at a given level. Currently, two methods of obtaining corium during experiments exist: in-pile and out-of-pile.

In the first case, for research aimed at studying the physical and mechanical properties of corium, the so-called "model corium" is obtained under in-pile test conditions. The peculiarity of the model corium is that it is obtained due to the decay heat of nuclear fuel contained in the composition of corium [5].

In the second case, in experiments on physical modeling of processes occurring in severe accidents, the so-called "prototype corium" is used, a substitute whose characteristics are close to real corium in most parameters, but do not create a dose load on personnel (hereinafter corium is understood as prototype corium) [6]. Since in experiments with prototype corium it is not possible to maintain the temperature of corium within the specified limits due to radioactive decay, this process is carried out by external energy supply to the corium melt using various devices. In this regard, the device providing energy input into the simulator melt should simulate the fission reaction both in magnitude and in the nature of its distribution through the volume of corium.

The purpose of this work is to conduct a comparative analysis of all existing methods of a decay heat simulation to determine the optimal way to fully simulate the thermal field of a real corium.

## **2. Practical methods of a decay heat simulation during various tests with corium**

Experiments to study the interaction between corium and various structural elements of a nuclear power plant began after the accident at the Three Mile Island NPP. At the same time, over the entire period of this type of research, a number of different experimental installations of different designs and devices have been created to simulate residual energy release. As an example, we can cite such methods of decay heat simulation used in experimental installations as methods of direct transmission of electric current through the melt (DEH) [7], induction heating [8], heating using thermite mixtures [9], indirect electric arc heating [10], etc.

### **2.1 Direct electric heating (DEH)**

Simulation of a decay heat in corium by direct transmission of electric current (DEH) was used in the first experiments to study the interaction of the corium with various structural elements. Some examples in this regard are the series of ACE/MC, MAKE and NEAM SI experiments [11]. These experiments allowed specialists to obtain a lot of information about the interaction between corium and various types of concrete used at power plants operating at that time. Figure 1 shows a schematic diagram of the experimental device when conducting experiments of the NEA-MCCI series.

The method of passing an electric current through the melt is implemented using two opposite walls of MgO lined with tungsten electrodes. During the experiment, an electric current was conducted through a central transverse span of electrodes that were in direct contact with the corium melt. The decay heat compensation system is built in such a way that, as the tungsten electrodes in direct contact with corium fail and the side walls erode, additional electrodes were exposed to the surface of the corium melt, to which an electric current is applied, thereby maintaining a homogeneous picture of heating the melt during the experiment. Thus, such a solution allows maintaining a constant rate of melt heating despite the failure of the tungsten electrodes and erosion of the side walls of the experimental section in an aggressive corium environment [12]. The electrical conductivity of the melt is very uncertain and unstable for each experiment due to changes in composition due to chemical interactions between corium and structural elements. This is the disadvantage of using this method. After all, during experimental studies the amount of energy injected into the melt strongly depends on the electrical conductivity of the melt. In this regard, the power distribution in the melt is unknown with a high degree of accuracy, which significantly affects the accuracy of the results obtained.

### **2.2 Induction heating method**

A similar issue associated with the uncertainty of the electrical conductivity of corium also exists when using an alternative method of decay heat simulation - an induction heater. Induction method is the heating of materials by electric currents that are induced by the alternating magnetic field of the inductor.

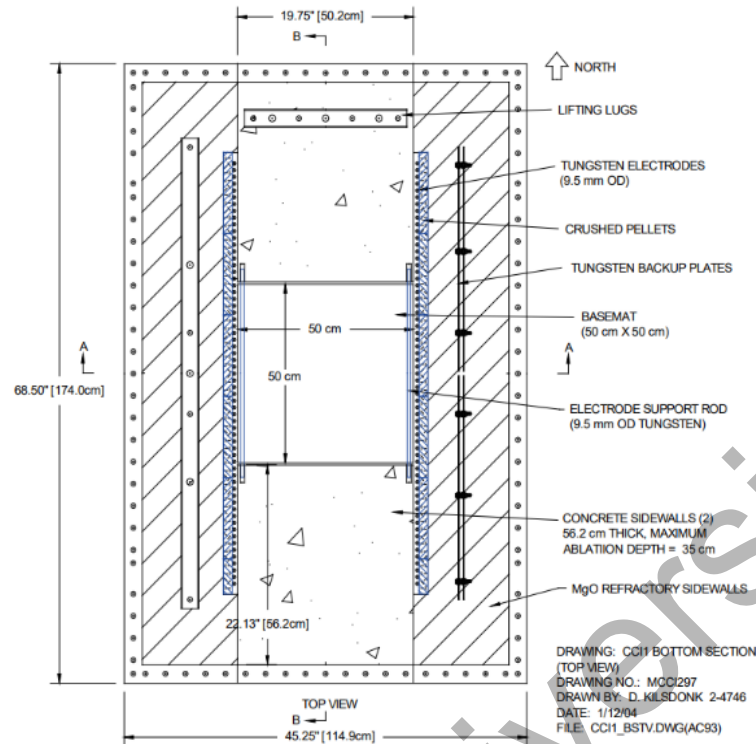

**Fig. 1.** Schematic diagram of the device used in the NEO-MCCI series experiments

Induction heating, as a method for simulating decay heat, is today the most widely used method when conducting experimental studies with corium melts, which is implemented in many large-scale and small-scale experimental installations, among which are such installations as: VULCANO, LAVA-B, VESTA, VESTA – S, BETA, COMET, COMETA, SICOPS, etc. [13-16]. Figure 2 shows schematic diagrams of some experimental installations.

In general, the principle of using an induction heater as a simulation method in various installations is identical. For example, at the LAVA-B and VESTA installations, corium is obtained in an electric melting induction furnace, which, after reaching the required temperature, is poured into a special experimental section surrounded by an induction heater, thereby simulating the decay heat in the melt, while the VULCANO installation differs from previously described installations only in the method of obtaining corium. The main advantage of induction heating is the non-contact method of transferring energy into the melt, which:

- 1) Eliminates the problem of contamination of the melt by foreign substances. For example, in the case of using electrodes with direct electric heating or thermite mixtures, which will be mentioned below;
- 2) Provides the possibility of long-term heating of corium in comparison with other methods of simulating decay heat in the experimental section, since the heating element is not in direct contact with the aggressive environment of the corium melt.

At the same time, despite the above advantages, installations for induction heating of corium have relatively low efficiency values. In addition, the efficiency of induction heating depends on many electrical and geometric parameters of both the inductor and the experimental section, which leads to the need to use more powerful sources of electricity to achieve the energy release in the melt required by the experimental conditions [17-18]. Another disadvantage of using an inductor is the pronounced surface skin effect. This means that most of the energy is released in some surface layer, which, in fact, is a disadvantage of induction heating as a method of simulating the residual energy release in the corium during experiments. For example, a situation may arise when, during induction heating, overheating of the surface layer of the melt will be observed, while the internal layers will not be heated sufficiently or even cooled, given the low thermal conductivity properties of corium.

### 2.3 Heating method using thermite mixtures

Decay heat is a feature of nuclear fuel, which means that under prototype conditions, heat generation is mainly concentrated in the oxide phase of corium.

This causes difficulties in reproducing such conditions during experimental studies, taking into account the currently available melt heating technologies. To some point this issue was managed in MOCKA experiments, where the heat of an aluminothermic exothermic chemical reaction was used to compensate the decay heat (Fig. 3). Such a chemical reaction releases a fairly large amount of heat, and the temperature of the mixture can reach 3000 °C.

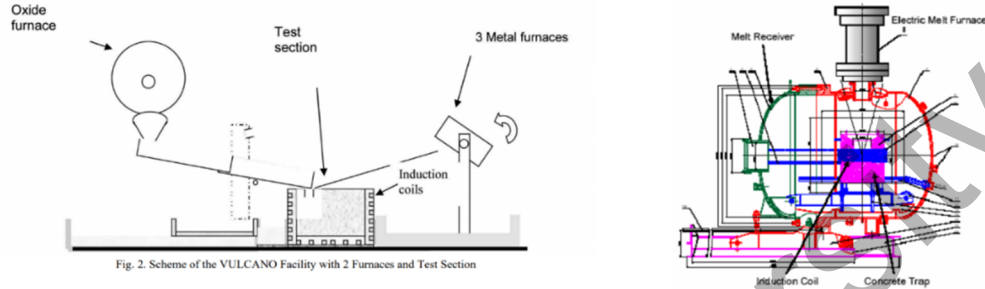

a) VULCANO installation

b) LAVA-B installation

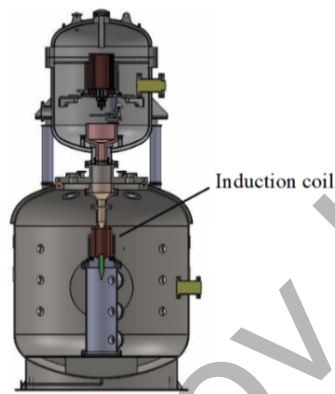

c) VESTA installation

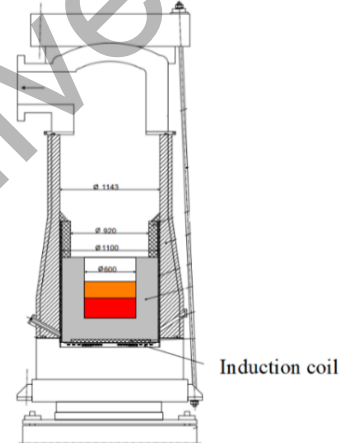

d) COMET installation

Fig. 2. Schematic diagrams of test devices

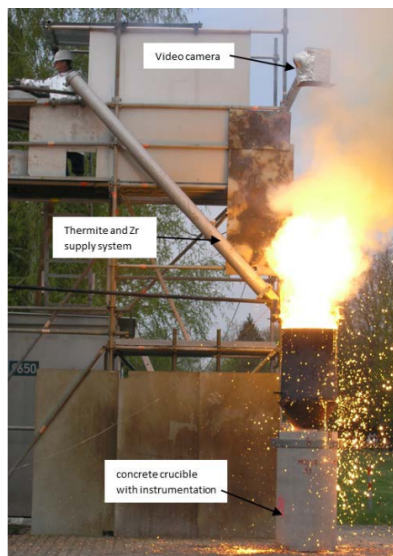

Fig. 3. MOCKA experimental installation

The advantage of this method, the authors point out, is the fact that during experiments, the heat released by the thermite reaction and the exothermic reaction of Zr oxidation is mainly deposited in the oxide phase (approximately 80% of the heating power was invested in the oxide phase and 20% in the metallic phase), which is not possible achieved using other methods for simulating decay heat. Unfortunately, this method is not a priority when choosing the most optimal simulation method due to the need to constantly add large volumes of new portions of thermite mixtures to maintain the simulation of decay heat. These actions lead to a significant change in the mass and chemical composition of the corium, which affects the nature of the interaction of the corium with various structural elements and can distort a reliable picture of the interaction occurring in a real situation.

#### 2.4 Indirect electric arc heating method

Another way to simulate decay heat release, which gives opportunity to the heat release in the required area of the melt, is the plasmatron method. This method was implemented on the basis of the branch of the Institute of Atomic Energy of the RSE NNC RK. During a series of INVECOR experiments to study the interaction of corium with the vessel of a light water reactor at the Lava-B installation, the indirect electric arc heating method was used, which uses the idea of the electroslag process and was implemented using closed-type coaxial plasmatrons immersed in the melt. To protect the heating device from corium, the plasmatrons were placed in special graphite tips. Figure 4 shows a schematic diagram of the experimental installation “Lava-B” with plasmatron heaters.

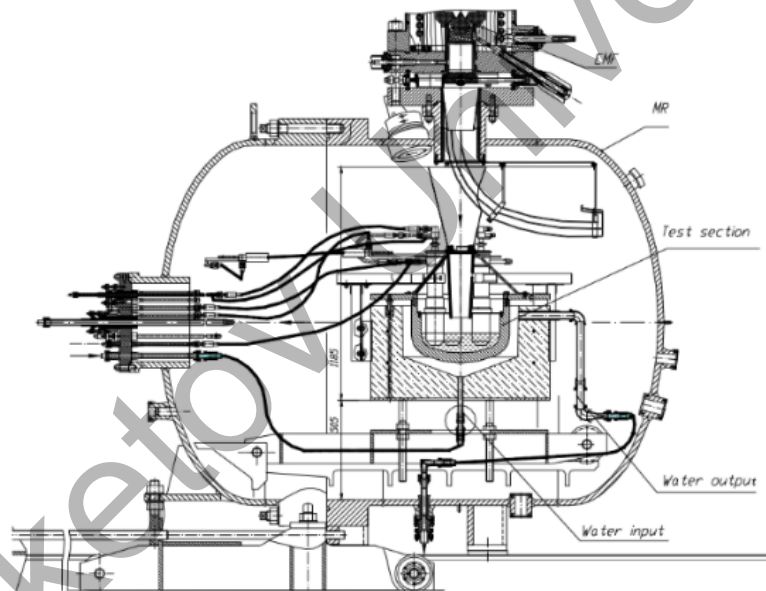

Fig. 4. Schematic diagram of the LAVA-B installation with plasmatron heaters

The advantage of indirect electric arc heating, for example, over induction heating or direct electric heating, is the absence of dependence on the electrically conductive properties of corium, since the transfer of energy to the melt is not associated with the flow of electric current in the melt. In this regard, the energy transferred to the melt can be determined with great accuracy.

The disadvantage of this method is the low unit power of plasma torches. In this regard, in order to achieve the required energy release in the melt, it is necessary to use a sufficient number of plasma torches, since a large amount of energy is required to maintain the corium simulator in the molten state when it interacts with various materials. As noted above, to protect plasmatronic heaters, they are placed in a special graphite tip. However, such graphite tips have a low durability in the aggressive environment of corium. This means that graphite plasma torch tips can significantly limit the possibilities of conducting an experiment, in particular regarding the duration of heating of the melt. To increase the service life of graphite tips, additional measures must be taken. For example, the use of a special zirconium carbide coating on the outer surface of graphite tips can extend the life of the tips to 2 hours at temperatures above 2500 °C, which fully satisfies the requirements of many experiments.

## 2.5 Ohmic heating method

Another method of decay heat release simulating, which was used in experiments with corium melts, is the method of electric heating by resistance. This method was used as part of the LIVE experiment on the installation of the same name (Fig. 5). The use of spiral heaters as in the LIVE installation, at first glance, is a more optimal way to simulate decay heat. Each heating plane consists of a spiral-shaped heating element, located in a special cage to ensure proper placement. To ensure uniform volumetric energy release, the heating system has six heating planes at different heights with fixed distances between them. This arrangement of the heaters allows one to regulate the uniformity of heating throughout the volume of the corium melt.

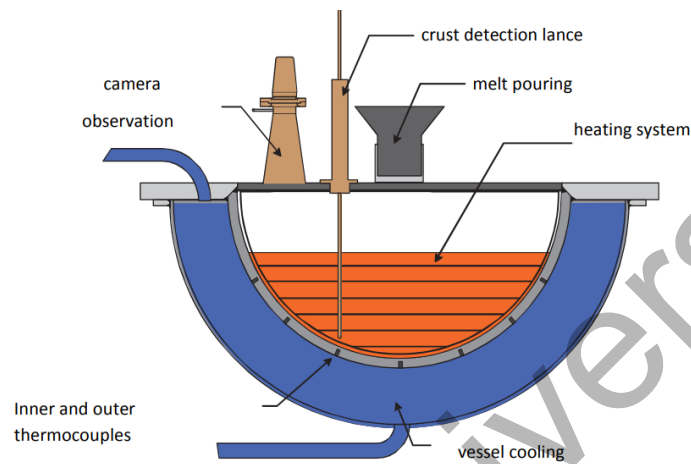

Fig. 5. Schematic diagram of the test section of the LIVE installation

However, the maximum permissible temperatures for indirect electric heating by the melt resistance in the LIVE installation were limited by the thermophysical properties of the spiral heater material, which was 1100 °C. This indicator is significantly lower than the required temperature values when conducting many experiments using a corium melt [19].

## 3. Comparative analysis, discussion

To select the optimal method for simulating decay heat in corium when conducting various studies on experimental installations by comparing the advantages and disadvantages, as well as suggesting possibilities for their improvement and assessing possible threats when conducting experiments, a SWOT analysis of the above methods was conducted, which is presented in Table 1. The review of practical methods for decay heat simulating in corium leads to the conclusion that all existing methods, although used at different experimental facilities to study the interaction of corium with structural materials, cannot fully simulate the thermal qualities of real corium.

At the same time, according to the table, induction, electric arc and ohmic heating are considered the most optimal. It is worth noting that various studies are currently being conducted on the interaction of corium with structural materials such as steel, concrete, sacrificial and heat-resistant materials, etc. This means that the choice of method for simulating residual energy release should be determined by the specifics of experimental research. For example, when studying the interaction of corium with steel, induction heating cannot be used as a method for simulating decay heat. This is due to the fact that, once exposed to the electromagnetic field of the inductor, the steel will heat up, thereby distorting the picture of the real interaction. In this regard, it is recommended to use methods of indirect water energy into the melt such as ohmic and electric arc heating.

Induction and plasmatron methods for simulating decay heat in the corium in relation to the LAVA-B installation are discussed in detail in paper [20]. Based on the fulfilled work, the parameters of heating the melt by each of the methods under consideration were determined, they were compared, the limits of their applicability for simulating residual energy release were determined, as well as the possibilities for further use.

The use of spiral heaters in the LAVA-B installation as in the LIVE installation, at first glance, is a more optimal method to simulate decay heat. The system for simulating decay heat is a device (Fig. 6), where each heating plane consists of a spiral-shaped heating element located in a special cage to ensure correct placement. This arrangement of the heaters allows one to regulate the uniformity of heating throughout the volume of the corium melt. To ensure uniform volumetric energy release, the heating system has six heating planes at different heights with fixed distances between them.

**Table 1.** SWOT analysis of methods for decay heat simulating.

Methods of decay heat release simulation:	Strength	Weakness	Opportunities	Threats
Induction heating	Non-contact heating of corium, heating duration	Low efficiency factor, skin effect	Increasing efficiency by optimizing the parameters of the induction system	All conductive materials are subject to heating
Indirect electric arc heating method	No dependence on the conductive properties of corium	Low unit power of the plasma torch	The possibility of increasing the heating efficiency by using several plasma torches	Limited heat transfer area
Direct electric heating	High heating temperature	The time limit of the experiment due to the failure of tungsten electrodes	Missing	Dependence of the amount of energy injected into corium on its electrical conductivity
Heating method using thermite mixtures	High heating temperature (up to 3000°C)	Short-term heating	Missing	Changes in the physical and chemical properties of corium
Ohmic heating (resistive heating)	Provides sufficient uniformity of heating of the melt throughout the volume	Low heating temperature	Increasing the maximum heating temperature due to the use of refractory materials	The threat of melting of the heater in the active medium of corium



**Fig. 6.** Ohmic heater in LIVE experiment

At the same time, the problem of temperature limitation of the use of a spiral heater can be solved by using more refractory metals as a material for its manufacture. One of the most optimal metals is tungsten, which has a melting point of over 3000 ° C, which is significantly higher than the operating temperatures when conducting experiments with corium. In the ANSYS program, an ohmic heater model was built based

on the parameters of the experimental installation of the LAVA-B melt subreactor trap. The appearance of the heater, height is 240 mm, diameter is 190 mm, and the wire diameter is 1 mm, is shown in Figures 7 and 8.

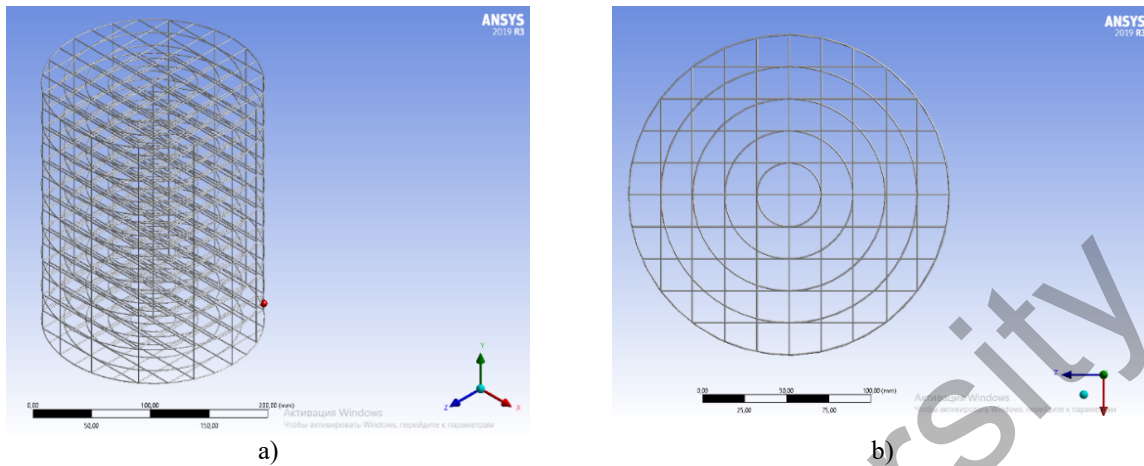

a) b)  
**Fig. 7.** Type of heater a) in an isometric system, b) in the XZ plane

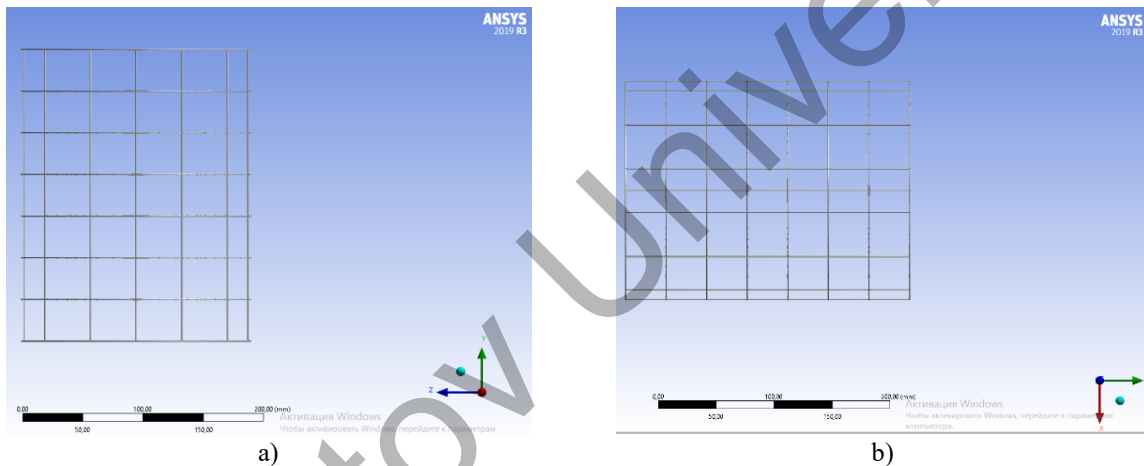

a) b)  
**Fig. 8.** Type of heater a) in an isometric system, b) in the XZ plane

In further studies, electrical calculations of heaters with different parameters will be carried out, as well as thermal calculations of corium during the use of this heater in a melt trap at the LAVA-B installation.

#### 4. Conclusion

Five methods of decay heat simulating in corium were considered in this paper. According to the results of the comparative analysis, it turned out that each of the methods has the following strengths and weaknesses. The induction method, although it provides long-term heating and is a non-contact heating method, but due to the low efficiency and skin effect, it cannot provide sufficient compliance with the picture of the thermal field of real corium. In addition to the listed disadvantages, all conductive materials of the experimental installation will be heated during the application of this method. The plasmatron method does not depend on the electrical conductivity of corium, but due to the low unit power of the plasmatron this method requires the use of several plasmatrons. However, even with the installation of several plasmatrons, the corium heat transfer area will be limited. During the application of the method of direct transmission of electric current through the melt, it becomes possible to achieve high temperatures, but the duration of heating will depend on the duration of operation of the electrodes. The method of heating with thermite mixtures is described with the same short heating duration. The only advantage of this method is the achievement of high temperatures, and the main disadvantage is the change in the physical and chemical properties of corium during the application of this method. Of all the methods considered, ohmic heating is

the only method that provides a uniform thermal field throughout the entire volume. Moreover, it is possible to change the nature and intensity of melt heating by using heaters of different shapes and parameters. There are also prospects for improving the effectiveness of this method through the use of refractory metals.

Taking into account these data and the possibilities of using each of the methods of simulating residual energy release in experiments with different specifics, it can be concluded that the most optimal of all existing methods is ohmic heating. The study of the possibility and practicality of using the ohmic heating method opens up the possibility for further experiments at the LAVA-B installation, which in turn will allow us to investigate the processes occurring during a severe accident at a nuclear power plant.

#### Conflict of interest statement

The authors declare that they have no conflict of interest in relation to this research, whether financial, personal, authorship or otherwise, that could affect the research and its results presented in this paper.

#### CRedit author statement

Skakov M.K., Baklanov V.V.: Conceptualization, Methodology; Nurpaissova G.S., Toleubekov K.O.: Data curation, Writing- Original draft preparation; Akaev A.S., Bekmuldin M.K.: Writing- Reviewing and Editing; The final manuscript was read and approved by all authors.

#### References

- 1 Molchanov I.A., Shumilin M.P. Retention of the core melt inside the containment during severe accidents of nuclear power units. *Eastern-European journal of enterprise technologies*, 2011, Vol. 2, No. 8(50), pp. 65-67. <https://doi.org/10.15587/1729-4061.2011.1843> [in Russian].
- 2 Dolganov K.S. Possibility of misleading readings of water level in VVER steam generator during severe accidents with account for the Fukushima lessons. *Nucl. Eng. Des.*, 2023, Vol. 413, <https://doi.org/10.1016/j.nucengdes.2023.112519>
- 3 Skakov M.K., Toleubekov K.O., Baklanov V.V., Gradoboev A.V., Akayev A.S., Bekmuldin M.K. The method of corium cooling in a core catcher of a light-water nuclear reactor. *Eurasian phys. tech. j.*, 2022, Vol. 41, pp. 69–77. <https://doi.org/10.31489/2022No3/69-77>
- 4 Bondar F.D., Artamonov M.V., Sidorov A.S. The influence of the accuracy of the calculation of residual energy release on corium catcher justification during BDBA. *Journal of Physics: Conf. Series*, 2018,, pp. 1-10. DOI:10.1088/1742-6596/1133/1/012014
- 5 Mukhamedov N.Ye., Kozhakhmetov Ye.A., Tskhe V.K. Microstructure and mechanical properties of the solidified melt obtained by the in-pile test. *Annals of Nuclear Energy*, 2022, pp. 179. <https://doi.org/10.1016/j.anucene.2022.109404>
- 6 Andrushechko S.A., Afrov A.M., Vasiliev B.Yu. *WWER-1000 reactor NPP. From physical basis of operation up to project evolution*, Logos. 2010. pp. 604. [In Russian] [https://elib.biblioatom.ru/text/andrushechko\\_aes-s-reaktorom-vver-1000\\_2010/p0/](https://elib.biblioatom.ru/text/andrushechko_aes-s-reaktorom-vver-1000_2010/p0/)
- 7 Fink J.K., Thompson D.H., Spencer B.W. Aerosol and melt chemistry in the ACE molten core-concrete interaction experiments. *High Temperature and Materials Science*. 1995. Vol. 33(1), pp. 51-76. [https://inis.iaea.org/search/search.aspx?orig\\_q=RN:27019724](https://inis.iaea.org/search/search.aspx?orig_q=RN:27019724)
- 8 Journeau C., Piluso P., Haquet J.F. Two-dimensional interaction of oxidic corium with concretes: The VULCANO VB test. *Annals of Nuclear Energy series*, 2009, Vol. 36, pp. 1597– 1613. <https://doi.org/10.1016/j.anucene.2009.07.006>
- 9 Foit J.J. MCCI of a Metal and Oxide Melt with Reinforced Siliceous Concrete in MOCKA Experiments. *Proc. of the 22<sup>nd</sup> Intern. Conf. on Nuclear Engineering*, Prague, Czech Republic, 2014. <https://doi.org/10.1115/ICONE22-30200>
- 10 Baklanov V.V., Zhdanov V.S., Malysheva Ye.V. Experimental study of processes during retention of corium melt in the reactor vessel (INVECOR). *Bulletin of NNC RK*, 2009, Vol. 37, pp. 55-65. [In Russian] <https://www.nnc.kz/media/bulletin/files/AIVJZeUkppq.pdf>
- 11 Foit J.J. Experiments on MCCI with oxide and steel. *Annals of Nuclear Energy*, 2014, Vol.74, pp.100 – 109. <https://doi.org/10.1016/j.anucene.2014.06.025>
- 12 Farmer, M.T., Lomperski, S., Kilsdonk, D.J. *OECD MCCI-2 Project Final Report. OECD/MCCI*. 2010. Vol. 07, pp. 91. <https://doi.org/10.13140/RG.2.2.27550.79687>
- 13 Journeau C. Contributions of the VULCANO Experimental Programme to the Understanding of MCCI Phenomena. *Nuclear engineering and technology*, 2012, Vol. 44 (3), pp. 261-272. <https://doi.org/10.5516/NET.03.2012.703>

14 Maruyama Yu., Tahara M., Nagasaka H. Recent results of MCCI studies in COTELS project. *Proceeding of the 3<sup>rd</sup> Korea-Japan Symposium on Nuclear Thermal Hydraulics and Safety Kyeongju*, Korea, 2002. <https://doi.org/10.13140/2.1.3997.1206>

15 Song, J., Kim, H., Hong, S. A use of prototypic material for the investigation of severe accident progression. *Progress in Nuclear Energy*, 2016, Vol. 93, pp. 297–305. <https://doi.org/10.1016/j.pnucene.2016.09.003>

16 Spindler B., Atkhen, K., Cranga M. Simulation of Molten Corium Concrete Interaction in a Stratified configuration: the COMET L2-L3 Benchmark. *Proceeding of the 2<sup>nd</sup> European Review Meeting on Severe Accident Research (ERMSAR-2007)* Karlsruhe, Germany, 2007. [https://www.researchgate.net/publication/239556995\\_Simulation\\_of\\_Molten\\_Corium\\_Concrete\\_Interaction\\_in\\_a\\_Stratified\\_Configuration\\_the\\_COMET-L2-L3\\_Benchmark](https://www.researchgate.net/publication/239556995_Simulation_of_Molten_Corium_Concrete_Interaction_in_a_Stratified_Configuration_the_COMET-L2-L3_Benchmark)

17 Bekmuldin M.K., Skakov M.K., Baklanov V.V. Experimental Simulation of Decay Heat of Corium at the Lava-B Test-Bench. *Nuclear Technology*, 2023, Vol.210, pp. 46-54. <https://doi.org/10.1080/00295450.2023.2226539>

18 Toleubekov K.O., Akaev A.S., Bekmuldin M.K. Improving the efficiency of the induction heating system to simulate decay heat in corium when interacting with heat-resistant materials. *Bulletin of the NNC RK*, 2020, Vol. 4, pp. 47-52. [In Russian] <https://www.nnc.kz/media/bulletin/files/wus815EKb2.pdf>

19 Miassoedov A., Cron T., Gaus-Liu X. LIVE experiments on melt behavior in the reactor pressure vessel lower head. *Proceeding of the 8<sup>th</sup> Intern. Conf. on Heat Transfer, Fluid Mechanics and Thermodynamics*, 2011. Vol. 34(14), pp. 793 – 801. <https://doi.org/10.1080/01457632.2013.777247>

20 Toleubekov K.O. Modeling the process of decay heat imitation in the corium at the Lava-B facility. *Recent Contributions to Physics*, 2022, Vol. 81, No 2, pp. 97-106. <https://doi.org/10.26577/RCPH.2022.v81.i2.012>

---

## AUTHORS' INFORMATION

**Skakov M.K.** - Doctor of phys.-math. sciences, Professor, Chief Researcher, National Nuclear Center of the Republic of Kazakhstan, Kurchatov, Kazakhstan; ORCID ID: 0000-0003-3716-8846; [skakov@nnc.kz](mailto:skakov@nnc.kz)

**Baklanov V.V.** - PhD, First Deputy Director, Institute of Atomic Energy of the National Nuclear Center of the Republic of Kazakhstan, Kurchatov, Kazakhstan; ORCID ID: 0000-0001-7627-8752; [baklanov@nnc.kz](mailto:baklanov@nnc.kz)

**Nurpairova G.S.** - PhD student, Shakarim University, Semey, Kazakhstan; Engineer, Laboratory of Experimental Thermophysics, Institute of Atomic Energy of the National Nuclear Center of the Republic of Kazakhstan, Kurchatov, Kazakhstan; ORCID ID: 0009-0004-5573-1510; [nurpairova@nnc.kz](mailto:nurpairova@nnc.kz)

**Akaev A.S.** – Head of the Department of non-reactor tests, Institute of Atomic Energy of the National Nuclear Center of the Republic of Kazakhstan, Kurchatov, Kazakhstan; ORCID ID: 0000-0003-4792-6161; [akaev@nnc.kz](mailto:akaev@nnc.kz)

**Bekmuldin M.K.** - PhD student, Shakarim University, Semey, Kazakhstan; Head of the group of the Laboratory of Experimental Thermophysics, Institute of Atomic Energy of the National Nuclear Center of the Republic of Kazakhstan, Kurchatov, Kazakhstan; ORCID ID: 0000-0002-6895-536X; [bekmuldin@nnc.kz](mailto:bekmuldin@nnc.kz)

**Toleubekov K.O.** - PhD student, Shakarim University, Semey, Kazakhstan; Junior Researcher, Laboratory of Experimental Thermophysics, Institute of Atomic Energy of the National Nuclear Center of the Republic of Kazakhstan, Kurchatov, Kazakhstan; ORCID ID: 0000-0001-8731-363X; [toleubekov@nnc.kz](mailto:toleubekov@nnc.kz)