

ASSEMBLING A MULTISENSORY DEVICE FOR MONITORING AND ASSESSING CONCRETE CURING CONDITIONS

Utepov Ye.B.^{1,2}, Tolkynbayev T.A.¹, Aniskin A.³, Akhazhanov S.B.⁴, Zharassov Sh.Zh.^{1,2*}, Tulebekova A.S.^{1,2}, Akishev M.S.^{2,5}

¹ L.N. Gumilyov Eurasian National University, Nur-Sultan, Kazakhstan, [*zhshzh95@gmail.com](mailto:zhshzh95@gmail.com)

² CSI Research & Lab (LLP), Nur-Sultan, Kazakhstan

³ University North, Varaždin, Croatia

⁴ E.A. Buketov Karaganda University, Karaganda, Kazakhstan

⁵ BI Group (JSC), Nur-Sultan, Kazakhstan

The conventional direct and indirect methods to study the mechanical characteristics of concrete are mainly performing discrete measurements, omitting the continuous internal and external phenomena occurring in the concrete body that may significantly affect its strength and quality. This study presents a multisensory device and a method that simultaneously measures and assesses the impact of curing temperature, ambient temperature and relative humidity on the concrete strength. The device was assembled on the basis of Arduino Pro Mini microcontroller connected with various sensors, as well as clock reading and memory modules. The method proposed to assess the impact of different factors on concrete strength is based on strength tests and their confidence curve, monitoring of concrete curing conditions, correlation and weighting techniques. The performance of proposed device and its method was justified experimentally using the concrete cubic specimens of different size. To visualize the specimens monitoring results the color gradations, petal and bar chart representations were used, and taken into account for the future implementation of a software interface for the multisensory device.

Keywords: concrete strength, sensors, continuous phenomena, Arduino, monitoring.

Introduction

There exist many methods to control the concrete strength both in the laboratory and construction site, depending on the structure and the applied load. A distinction is made between direct and indirect methods. Often construction crews use indirect methods in the initial stages of concrete curing to save on laboratory costs. Direct methods are mostly used during the scheduled curing periods (i.e., 3, 7, and 28 days) of concrete to obtain test reports allowing further loading of the structure [1]. The strength control methods by which structural loading decisions made are based on standards or regulatory documentation on a national, regional or organizational scale. The importance of this documentation is justified by international design standards, because through these documents, one community is in contact with another under predetermined regulations. There are different categories of this documentation: standards, codes, specifications, and other national regulations. Abroad, in such countries as the United States, Great Britain, Germany, Australia, and Japan, there are entire communities to control and improvement of regulations in this direction [2]. It is worth noting that independent institutions also make adjustments in the application of standards; their number is not great, but cooperation is at a high level.

All standards take into account the influence of various external and internal factors on the concrete strength gain. [3] identified about 20 influencing factors. It is not easy to judge the degree of influence of one or another factor at the time of concrete strength gain as it is a complex process, but summarizing it is possible to classify them into 3 groups: 1) Factors affecting the strength before concrete batching; 2) Factors affecting the strength at the time of batching the concrete; 3) Factors affecting the strength after concrete batching. The predominance of one of the groups in case of non-

compliance with the technology of production of concrete is revealed only at the stage of its strength gain, which is fraught with financial and time losses [2].

Most of the errors that reduce the design strength of the structure is associated with the 3rd group of factors, in the period of care of the concrete. This is justified by the fact that factors 1 and 2 are formed in the laboratory or factory conditions, where the probability of making an error in the technology of concrete batching is negligible, which is not possible to state about the field temperature and humidity conditions. As much depends on the process of paving and care of the concrete. It should be noted that the paving process, depending on the volume can take several hours or even a whole day. While care, regardless of the volume lasts all 28 days without exception. During this time, the concrete is exposed to many internal and external factors and their study provides an opportunity to properly examine their impact on the structure to avoid risks that can lead to dire consequences. Conventional methods [4,5] do not provide a detailed picture on the processes taking place in the concrete body, since they are based on mechanical reactions when being applied. Also, they examine characteristics on certain points or parts of structure, but not a whole, and reveal discrete values. As is known, the most influencing factors for concrete strength are curing temperature, ambient temperature and relative humidity. All three are continuous phenomena [6]. Therefore, to monitor their impact and make timely and preventive decisions, corresponding techniques and equipment should be used. One of promising techniques is application of maturity sensors [7–9] that enable estimation of concrete strength using a predefined maturity-strength relationship. However, these sensors may register mostly only curing temperature; but those for several parameters – disable simultaneous measurements. Therefore, to take into account external factors, these sensors need to be substantially redesigned. Moreover, the Maturity methods [10] that they apply do not consider joint effect of internal and external factors on concrete strength. The literature lacks sensor-based solutions on real-time monitoring of concrete curing conditions taking into account several factors at a time. In addition, the proper method to examine the patterns between the concrete strength and influencing factors are poorly addressed in previous studies [11–15]. These patterns appear to be important to assess the degrees of impact of the factors on concrete strength.

In view of the above, this work is aimed at the development of a multisensory device for monitoring and a method for assessing concrete curing conditions. The device is assembled from sensors for concrete curing temperature, ambient temperature and relative humidity on the basis of Arduino microcontroller. The assessing method is based on strength tests, monitoring of parameters, correlation analysis to recognize patterns of interdependency of parameters with concrete strength [16], calculation of parameter weights, as well as visual representation of the patterns. The calculation of weights is assumed to be a proper technique to demonstrate the degree of influence of the parameters.

1. Development of multisensory device

The multisensory device (MSD) development was carried out in steps. The first step was to design the IT-architecture that consisted of microcontroller Arduino Pro Mini (1), four waterproof temperature sensors DS18B20 (2), ambient temperature and relative humidity module DHT11 (3), real time clock module DS3231 (4), micro-SD card module (5) with the card (6), and two Li-ion batteries INR18650-20S 3.7V connected in parallel (7) as shown in Fig. 1.

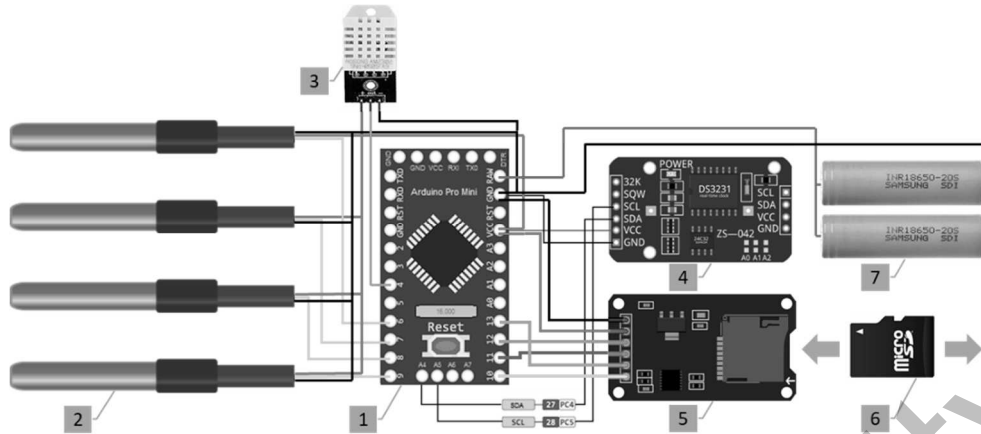

Fig. 1. MSD IT-architecture

The next step was to solder the components together according to the connections indicated in the IT-architecture, for which an electric soldering iron was used. Further steps were to program the microcontroller in “C” language using an open-source Arduino integrated development environment (or Arduino IDE), to conduct test measurements and validate the measurement interval, saving to the SD card, as well as structure and content of the measurement data. Final step was to envelop the electronic components into a safe housing, for which a standard plastic case with dimensions of 15×10×5 cm was chosen (Fig. 2).



Fig. 2. Programming the microcontroller of MSD

It should be noted that the developed MSD has not the same design and functionality as its analogues [7–9,14,15]; it has certain differences that makes it more convenient to use: 1) Reusability (only wired temperature sensors are replaced), since the analogues are mostly embedded fully in the concrete body forever and each time new device should be purchased; 2) Storage of monitoring data in a single SD card that is easy to extract and use in PCs; 3) Central control of sensors via a single microcontroller, which makes synchronic and accurate measurements without the risk of data loss; 4) Longer service life due to energy-efficient components, powerful battery and efficient electronic circuit (analogues are mostly based on energy-intensive IoT concepts). Therefore, this makes MSD a fairly affordable alternative for construction companies of all sizes.

2. Materials and methods

The experimental studies were carried out using a commercial concrete with grade of B25 M350 produced by LLP "Temirbeton-1" (Almaty, Kazakhstan). Freshly mixed concrete was used to prepare 15 small cubic specimens with rib size of 10 cm and 2 large cubic specimens with rib size of 50 cm

for the testing procedures. Testing equipment composed of a newly developed MSD with measurement accuracy of $\pm 0.1^\circ\text{C}$ for temperature and 1% for relative humidity, hydraulic press from NIISTROMPROJECT, LLP (Almaty, Kazakhstan) with accuracy of $\pm 1\%$ and sclerometer IPS-MG4.03 from CSI Research&Lab, LLP (Nur-Sultan, Kazakhstan) with accuracy of $\pm 8\%$.

Compression testing of small cubic specimens was carried out using the hydraulic press in series of 3 cubes on 1, 3, 7, 14 and 28 days of curing according to [4] (Fig. 3a). On the same curing ages, the large specimens were tested for strength on the side surfaces using the sclerometer according to shock pulse method [5], for which the average values from the two specimens were deduced (Fig. 3b). It was the average strength values that were used for further analysis. The curing temperature of large specimens, as well as ambient temperature and relative humidity on their curing conditions were measured each 0.5 hours [17] (Fig. 3c). The strength values at 1, 3, 7, 14, 28 days of curing were obtained in the course of testing of small and large specimens (Table 1) and strength curves were plotted according to them later.

Further the received curves have been superimposed on the single diagram and on their crossings the *confidence curve* (i.e., containing the least of values received by methods of compression and a shock pulse) was detected. In order to accurately determine the values of the confidence curve for both strength gain curves (for compression and for shock pulse), the trend lines were constructed, their equations and approximation reliabilities (coefficients of determination) were extracted. The equations made it possible to calculate the strength values for every 0.5 hours.

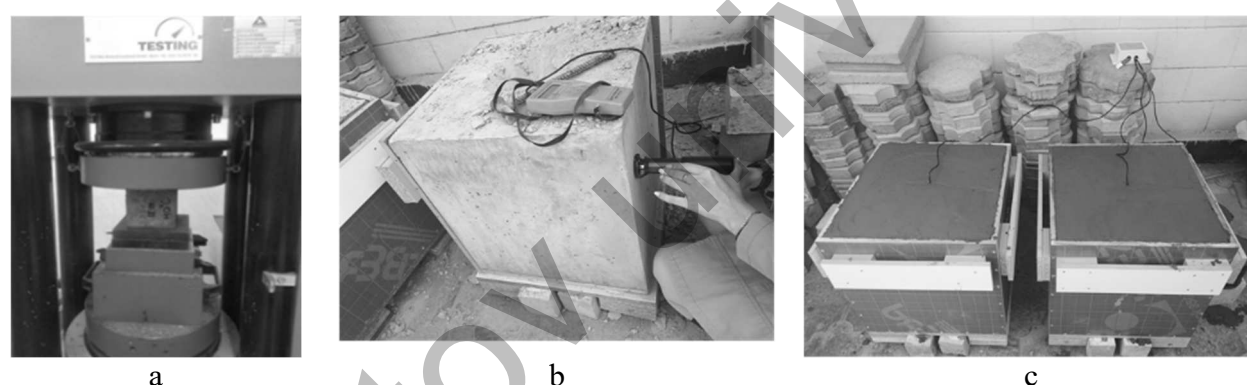

Fig. 3. Testing setup: a) compression test; b) shock pulse test; c) temperature and humidity monitoring.

Table 1 – Strength test results

Age, day	Compressive strength of small cubes (average of 3 per day)	Surface strength of large cubes, MPa		
		No. 1	No. 2	Average in cubes
1	14.2	10.15	10.35	10.25
3	20.45	24.25	21.65	22.95
7	25.25	27.75	28.45	28.1
14	28.75	30.3	29.95	30.13
28	33.2	31.3	31.35	31.33

Confidence curve values were determined for each 0.5 hour by selecting the lowest of the curve values (i.e., from compression and shock pulse tests) with an accuracy of 99.9%. Table 2 below was prepared to better structure the estimated values and monitoring readings for further analysis and assessment of curing conditions of considered B25 M350 concrete.

Table 2 – Hourly estimates and readings

Age, hour	Curing temperature of large cubes, °C			Relative humidity, %	Ambient temperature, °C	Compressive strength, MPa	Surface strength (average), MPa	Strength values of confidence curve, MPa
	No. 1	No. 2	Average					
0.5	21.44	20.5	20.97	29.7	23.9	0.29583333	0.21354167	0.21354167
1	21.63	20.75	21.19	30.6	23.4	0.59166666	0.42708333	0.42708333
1.5	22	21.19	21.595	33.8	23.3	0.8875	0.640625	0.640625
2	22.5	21.69	22.095	31.3	23.2	1.18333333	0.85416667	0.85416667
2.5	23.13	22.31	22.72	30.9	23.5	1.47916667	1.06770833	1.06770833
etc.*								
24	32.5	32.88	32.69	33.1	22.6	14.198	10.25	10.25
etc.*								
671	8.13	7.44	7.785	43.7	12.9	32.9875642	31.3221343	31.3221343
671.5	8.31	7.69	8	43.1	13.2	32.9917663	31.3234239	31.3234239
672	8.63	7.88	8.255	40.9	13.8	32.9959653	31.3247124	31.3247124

* Since the table contains 1344 lines of data, majority of them were omitted.

Subsequently, these values were used to determine the daily correlation coefficients [16] (Eq. 1) with the values of the parameters of curing temperature, ambient temperature and relative humidity, as well as to determine the degree of influence (Eq. 2) of these parameters on the concrete strength gain.

$$r_{i,t} = \frac{\sum_{t=1/48}^1 (P_i - \bar{P}_i) \cdot (S - \bar{S})}{\sqrt{\sum_{t=1/48}^1 (P_i - \bar{P}_i)^2 \cdot \sum_{t=1/48}^1 (S - \bar{S})^2}} \tag{1}$$

where: i – parameter that affects the strength gain of concrete (there are three considered parameters in this study: curing temperature, ambient temperature, and relative humidity); t – curing time of concrete, which can range from 1/48 to 28 within this study, days; P_i and \bar{P}_i – i parameter and its average value for time t (day), respectively, in units of one or another parameter; S and \bar{S} – strength and its average value for time t (day) respectively, MPa.

$$\gamma_{i,t} = \frac{|r_{i,t}|}{\sum_{i=1}^3 |r_{i,t}|} \tag{2}$$

Here it should be noted that the sum of the degrees of influence must be equal to one (Eq. 3).

$$\sum_{i=1}^3 \gamma_{i,t} = 1 \tag{3}$$

The obtained values of correlation coefficients and degrees of influence were visualized using color gradations, petal diagram and bar chart, as potential representation of monitoring results that may be further integrated into a software interface of multisensory device. The accuracy of proposed assessment method mainly depends on the equipment used for compressive and shock pulse tests, which were $\pm 1\%$ and $\pm 8\%$ respectively in current study, since the uncertainty of MSD and its sensors is negligible. Therefore, the confidence curve is assumed a suitable and less risky approach to reduce potential losses of assessment accuracy.

3. Results and Discussion

The strength gain results of the two large specimens obtained with the shock pulse method are shown below in Fig. 4a. It can be seen from the strength gain curves that their difference is insignificant. Nevertheless, the curve of their average values at 1, 3, 7, 14, 28 days was used for further analysis. In Fig. 4b, the cubic marker shows the strength gain curve obtained by the compression testing of small specimens, which was compared with the average curve obtained by the shock pulse method, denoted by the triangular marker. The bold line indicates the confidence curve of the strength values. This curve is made up of the lowest strength values between the compression test and the shock pulse method for each curing age of concrete, to provide some redundancy. It

shows that for the first 2 days and the last 10 days, it coincides with the curve of average values of strength obtained by the shock-pulse method, and from day 2 to day 18 with the curve of strength values obtained by the compression testing of small specimens.

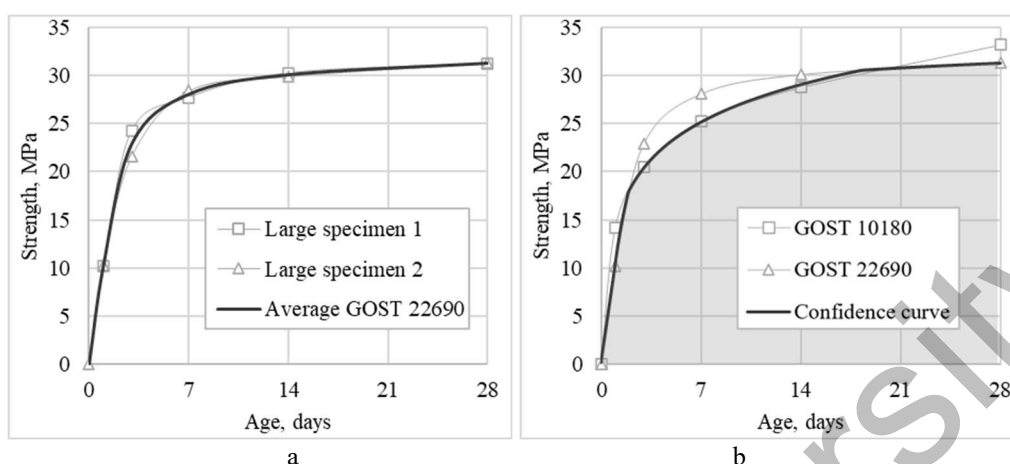

Fig. 4. Strength gain charts: a) shock pulse method; b) comparison and derivation of the confidence curve.

Figs. 5a and 5b show the trend lines, their equations and the coefficients of determination of the strength gain curves of the compression and shock impulse methods, respectively. According to the figures above, the trend lines were constructed in such a way that they converged to their strength gain curves as much as possible. For this purpose, sections were created with intervals of 0-1 and 1-28 days for the compression method curve, and 0-1, 1-3, 3-7, 7-14, and 14-28 days for the shock pulse method curve, respectively. For each of the sections, different equations and coefficients of determination (R^2) were derived. According to the values of these coefficients one can assert a high degree of approximation reliability. Thus, almost all R^2 of the obtained linear and logarithmic equations are equal to 1, with the exception of the one in the segment 1-28 days of the compression method curve. Given these coefficients as a percentage, their average value is 99.9%. Using the equations by section, the accurate strength values for every 0.5 hours up to and including 28 days were estimated for both methods.

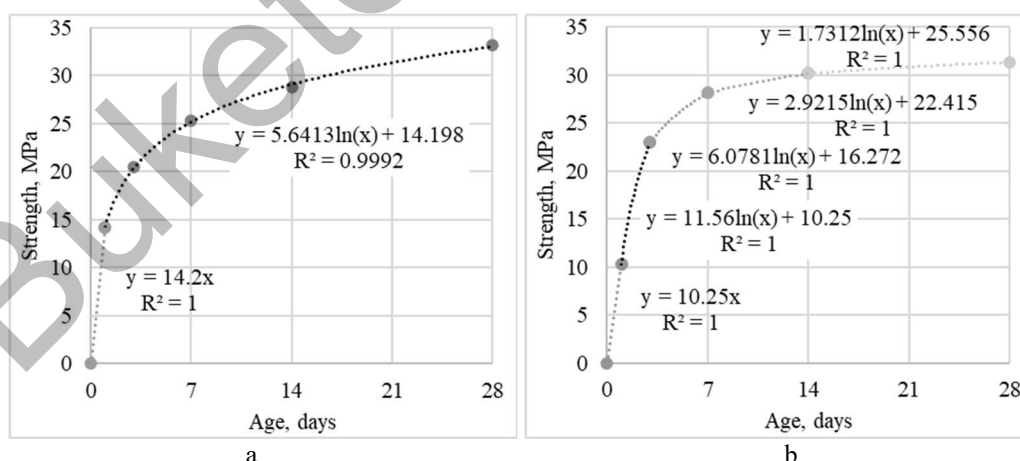

Fig. 5. Trend lines: a) compression method; b) shock pulse method.

Figs. 6a and 6b show the results of monitoring the curing temperature of the large specimens (average of two) and the air temperature and relative humidity in the specimens' storage area with intervals of 0.5 hours over a period of 28 days. Fig. 6a demonstrates a sharp jump in temperature to 36.7 °C on the first and second day of curing due to the beginning of concrete setting, after which a gradual decline with fluctuations during the day and night. Over 28 days, the minimum curing

temperature decreased to 2.65 °C. A similar trend can be observed in the ambient temperature curve (Fig. 6b), indicating its certain influence on the concrete strength gain process, as well as on the exothermic process itself occurring in its body. The air temperature varied between 2.2 and 24.8 °C. As can be seen in Fig. 6b, there is an inverse relationship between relative humidity and ambient temperature: as the temperature increases, the humidity decreases, and vice versa. The humidity varied between 24.9 and 100%, with an average value of 53.2%.

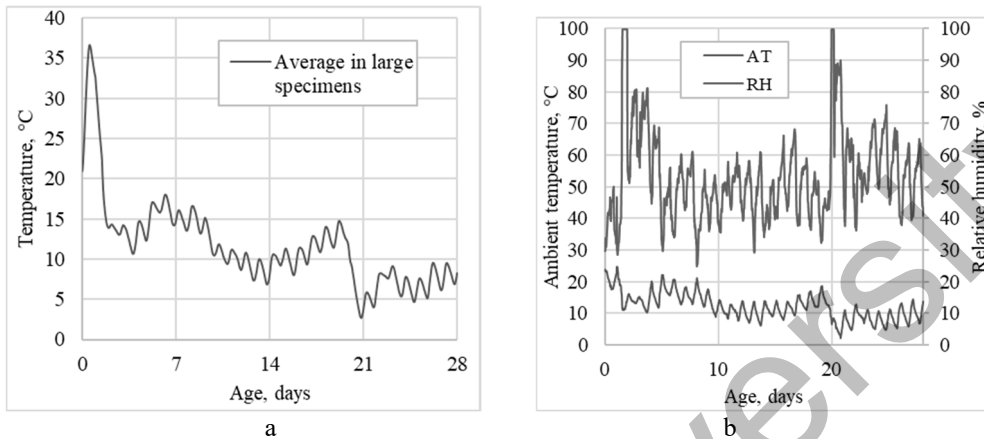

Fig. 6. Results of monitoring: a) curing temperature (T); b) ambient temperature (AT) and relative humidity (RH).

The next step, using Eq. 1, the correlation coefficients between the values of the 3 parameters considered and the strength of the confidence curve for each of the 28 days of concrete curing were estimated. The results of these estimates are shown in Fig. 7 as two-color gradations (white-green), with each cell assigned a shade depending on the modulus value of the correlation coefficients for all 3 parameters. In other words, the cells with the lowest values among all 84 (28×3) were tinted close to white, and the cells with the highest values were tinted green.

$ r_T $	0.8	1	0.8	0.9	0.4	0.1	0.9	0.8	0.8	0.9	0.9	0.9	0.9	0.8	0.1	0.9	0.5	0.6	0.6	0.9	1	0.2	0.1	0.9	0.8	0.5	0.9	0.7
$ r_{RH} $	0.2	0.8	0.5	0	0.2	0.3	0.7	0.2	0.9	0.3	0.8	0.4	0.4	0.3	0.6	0.4	0	0.1	0.2	0.7	0.6	0.1	0.4	0.5	0.2	0.1	0.4	0.3
$ r_{AT} $	0.5	0.9	0.5	0.2	0.2	0.5	0.8	0.3	0.7	0.8	0.8	0.6	0.6	0.5	0.6	0.5	0	0.2	0.3	1	0.4	0.2	0.8	0.6	0.4	0.1	0.4	0.4
AVG	0.5	0.9	0.6	0.4	0.2	0.3	0.8	0.4	0.8	0.7	0.8	0.6	0.6	0.5	0.4	0.6	0.2	0.3	0.4	0.9	0.7	0.2	0.4	0.7	0.5	0.2	0.6	0.5
Age, days	1	2	3	4	5	6	7	8	9	10	11	12	13	14	15	16	17	18	19	20	21	22	23	24	25	26	27	28

Fig. 7. Color gradation of correlation coefficients.

From the figure above, one can observe a markedly high correlation between curing temperature and concrete strength gain, especially on days 2, 4, 10, and 21, since the correlation coefficients at those days were within the range of 0.9 ÷ 1. Relative humidity and ambient temperature correlate well with strength on days 2, 9, 11, 20 and 23, with the correlation coefficients laying in the range of 0.4 ÷ 0.9. The cumulative correlation of the considered parameters with the strength, plotted red as an average between the three parameters for each day, vividly expressed cells on days 2, 7, 9, 11, and 20. This pattern can be further used in expressing the dependence (function) of the strength from the considered parameters, for which it would be logical to make a selection of parameter values exactly on 2, 7, 9, 11 and 20 days as the initial data. The degrees of influence of the considered parameters on the concrete strength gain, calculated according to Eqs. 2 and 3, are represented by a similar color gradation (Fig. 8) on the basis of white and blue.

γ_T	0.5	0.4	0.4	0.8	0.5	0.1	0.4	0.6	0.3	0.5	0.4	0.5	0.5	0.5	0.1	0.5	0.9	0.6	0.5	0.3	0.5	0.4	0.1	0.5	0.6	0.8	0.5	0.5
γ_{RH}	0.1	0.3	0.3	0	0.2	0.4	0.3	0.1	0.4	0.2	0.3	0.2	0.2	0.2	0.4	0.2	0	0.2	0.2	0.3	0.3	0.2	0.3	0.2	0.2	0.1	0.2	0.2
γ_{AT}	0.3	0.3	0.3	0.2	0.3	0.6	0.3	0.3	0.3	0.4	0.3	0.3	0.3	0.3	0.5	0.3	0.1	0.2	0.3	0.4	0.2	0.4	0.6	0.3	0.3	0.1	0.3	0.3
Age, days	1	2	3	4	5	6	7	8	9	10	11	12	13	14	15	16	17	18	19	20	21	22	23	24	25	26	27	28

Fig. 8. Color gradation of the influence degrees of parameters.

The results of the calculation of the degrees of influence for each of the 28 days show a fairly logical pattern. Thus, the figure above shows that the effect of curing temperature on the strength of the concrete noticeably prevails ($\gamma_{Tmax} = 0.9$) in comparison with those of the other two parameters ($\gamma_{RHmax} = 0.4$, and $\gamma_{ATmax} = 0.6$). However, at 6, 9, 15, 20, 22 and 23 days, the external temperature and relative humidity influenced more. Referring to Fig. 6a and 6b, it can be understood that it was on these days that the temperature and humidity conditions were quite critical for the concrete in the large specimens.

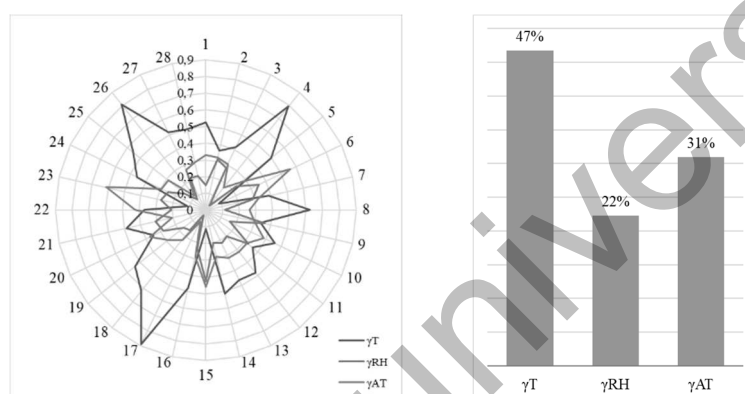

Fig. 9. Spatiotemporal representation of monitoring results as petal diagram (left) and bar chart (right).

An alternative representation of the results of calculating the degrees of influence is presented in Fig. 9a as a three-color petal diagram, where blue, orange, and gray colors correspond to the degrees of influence of curing temperature, relative humidity, and ambient temperature. The percentage ratio of the area of these petals is shown in Fig. 9b. The pattern can be seen that this ratio is equivalent to the ratio obtained by averaging the degrees of influence for all 28 days for each parameter separately. And their sum is always equal to 100%.

Conclusion

As a result of this work, a reusable multisensory device was developed that allows monitoring of concrete curing temperature, ambient temperature and relative humidity simultaneously, which indicates the advantage of the solution compared to previous works. Moreover, its electronic circuit administered by Arduino Pro Mini microcontroller ensure its longer service life due to energy-efficient components and powerful battery used, as well as a long-term economic benefit.

A method of assessing the influence of the main internal and external factors on the concrete strength gain, based on correlation analysis and weighting of parameters, has been proposed.

The proposed method for determining the concrete strength confidence curve, or in other words, the Least Risk values, may allow engineers and contractors to optimize construction phases, contribute to a reasonable reduction in project delivery time and reduce risks in the loading of concrete structures.

The color gradation and petal diagram offered to demonstrate the correlation and the degree of influence of one or another parameter by means of spatial-temporal visualization have potential to present the current picture of processes taking place in the concrete body quite qualitatively and

promptly and to communicate its nature to concrete engineers. These representation techniques will form the basis of the interface of the software, which is in the plans for future work.

Acknowledgments

This research was funded by the Science Committee of the Ministry of Education and Science of the Republic of Kazakhstan (Grant № AP08052033).

REFERENCES

- 1 Gerald B., Neville, P.E. The Strength of Concrete, in *Concrete Manual*. International Code Council. 2015, pp. 24–31. Available at: <https://shop.iccsafe.org/media/wysiwyg/material/9090S15-Sample.pdf>.
- 2 IAE. *Guidebook on non-destructive testing of concrete structures*. Vienna: IAEA. 2002. Available at: <https://www.osti.gov/etdeweb/servlets/purl/20305546>.
- 3 Prasad C. (no date) *20 Factors Affecting Durability of Concrete, Structural Guide*. Available at: <https://www.structuralguide.com/20-factors-affecting-durability-of-concrete/>.
- 4 GOST 10180. *Concretes. Methods for strength determination using reference specimens*. 2012. [in Russian]
- 5 GOST 22690. *Concretes. Determination of strength by mechanical methods of nondestructive testing*. 2015. [in Russian]
- 6 Lorkowski P. *Monitoring Continuous Phenomena*. CRC Press. 2021. doi: 10.1201/9780429440960.
- 7 Lukpanov R., et al. Performance of maturity method for estimation of concrete strength based on cubic specimens. *Technobius*. 2021, 1(4), p. 0008. doi: 10.54355/tbus/1.4.2021.0008.
- 8 Utepov Y.B. et al. Prototyping an embedded wireless sensor for monitoring reinforced concrete structures. *Computers and Concrete*. 2019, 24(2), pp. 95–102. doi: 10.12989/cac.2019.24.2.095.
- 9 Taheri S. A review on five key sensors for monitoring of concrete structures. *Construction and Building Materials*. 2019, 204, pp. 492–509. doi: 10.1016/j.conbuildmat.2019.01.172.
- 10 ASTM C1074. *Standard Practice for Estimating Concrete Strength by the Maturity Method*. USA, West Conshohocken, PA: American Society for Testing and Materials. 2019.
- 11 Sun B., et al. Prediction of early compressive strength of mortars at different curing temperature and relative humidity by a modified maturity method. *Structural Concrete*. 2021, 22(S1). doi: 10.1002/suco.202000041.
- 12 Soutsos M., et al. Effect of in situ temperature on the early age strength development of concretes with supplementary cementitious materials. *Construction and Building Materials*. 2016, 103, pp. 105–116.
- 13 Barroca N., et al. Wireless sensor networks for temperature and humidity monitoring within concrete structures. *Construction and Building Materials*. 2013, 40, pp. 1156–1166. doi: 10.1016/j.conbuildmat.2012.11.087.
- 14 Giatec S. *The World's Leading Wireless Concrete Sensor for Temperature and Strength Monitoring, Giatec Scientific Inc*. Available at: <https://www.giatecscientific.com/products/concrete-sensors/smartrock-maturity-meter/> (Accessed: 23 March 2022).
- 15 Hilti. *HCS THI Concrete Sensors, Concrete Monitoring Systems*. 2022. Available at: https://www.hilti.com/c/CLS_MEA_TOOL_INSERT_7127/CLS_CONCRETE_MONITORING_SYSTEMS/r13232456 (Accessed: 23 March 2022).
- 16 Novak L., et al. Estimation of coefficient of variation for structural analysis: The correlation interval approach. *Structural Safety*. 2021, 92. doi: 10.1016/j.strusafe.2021.102101.
- 17 Utepov Y.B., et al. Complex Maturity Method for Estimating the Concrete Strength Based on Curing Temperature, Ambient Temperature and Relative Humidity. *Applied Sciences*. 2021, 11(16), p. 7712. doi: 10.3390/app11167712.