

AUTOMATED TEMPERATURE AND HUMIDITY CONTROL AND MONITORING SYSTEM FOR IMPROVING THE PERFORMANCE IN DRYING SYSTEM

Alkhdery L.A.¹, Yurchenko A.V.², Mohammed J.A.-K.³, Neshina Y.G.^{4*}

¹National Research Tomsk Polytechnic University, Tomsk, Russia

²National Research Tomsk State University, Tomsk, Russia

³Electromechanical Engineering Dept., University of Technology, Baghdad, Iraq

⁴A. Saginov Karaganda Technical University, Karaganda, Kazakhstan, 1_neg@mail.ru

Temperature and relative humidity are the key control parameters in drying processes for preserving and improving food quality. To achieve this goal, an automatic control system has been designed and built to provide adequate heat and drying streams according to the ambient requirements of various climatic zones and the kind of dried product. The control system combined with sensors allows the temperature and humidity of the drying chamber to be adjusted online by predetermined parameters. When there is little or no radiation present or when rapid drying rates are required, the heated air stream may be produced utilizing an electric motor fan in addition to an electrical backup heater. The fan automatically modifies its speed using the Pulse Width Modulation technique for energy efficiency depending on the required temperature of the drying chamber. The control system based on Arduino Uno board is built within the solar dryer, after which tests are carried out. The test results are displayed on a display. The management system was set up to maintain an ambient temperature between 40 and 60 °C and relative humidity between 10 and 20 %. The system is a flexible solution for different climatic zones and dried products, according to experimental findings demonstrating its efficiency in managing the drying environment. Finally, this paper can conserve energy because it only works when the temperature around the food is below 60 °C.

Keywords: Solar dryer; temperature and humidity control; Arduino UNO; electric fan; backup heater; monitoring system, printed circuit boards

Introduction

Controlling the temperature of any room as a result of solar radiation is an essential responsibility in many automated activities. One of the important activities of the solar dryer is food applications [1,2]. Specialized sensors, ranging from simple to intelligent sensors, as well as the application of environmental monitoring, are used to detect the temperature in the room. There are several research publications on controlling room temperature, but few of them have used Arduino to autonomously manage room temperature and humidity, especially for monitoring purposes. We looked at several publications and have highlighted a few key points.

Abed [3] designed and evaluated the performance of a solar dryer, which is made of three basic parts, a drying solar collector, solar dryer chamber, and chimney. To improve the drying efficiency, a fan was installed at the chimney outlet to manually exhaust the hot air outside the solar dryer. A developed computational and experimental setup of a hybrid PV Thermal double-pass counterflow system coupled with a mixed-mode solar dryer system was suggested by Jadallah et al. [4]. The temperature of the solar cells was reduced by manually pumping air into the PVT system via a fan created by the PV module, hence increasing the PV module's electrical efficiency. The air is passed from the fan to the PVT solar system, then into the drying chamber, using the forced convection mode.

Some studies used different controllers and techniques to manage the climate inside the room. Abdullah et al. [5] presented a temperature control system concept that may be implemented on the Tudung Saji microcontroller. Both the hardware implementation and software simulation were tried and results were achieved. The goal of this study is to guard against bacteria when a particular temperature has been reached. The program appears to be quite excellent at managing and rather preventing bacteria, as bacteria may be

destroyed at a particular temperature. This might also be tried using the Arduino IDE. Widhiada et al. [6] recommended the introduction and designed a control system for temperature distribution for use in a newborn incubator. To ensure a baby's optimum health, it is critical to maintain a specified temperature within the room in this system. The experimental setup employed a microcontroller-based incubator system for temperature sensing and control including humidity as well. This has proven to be a very beneficial tool for baby care and wellness. Humidity was also taken into consideration in the experiment, which used a microcontroller-based system for measuring and controlling temperature. This was a critical application for the well-being and care of children.

Kesarwani et al. [7] produced a case study to control the temperature in systems using microcontrollers, bridge rectifiers, and TRIACs. To adapt temperature measurement, Bhatia, V. and G. Bhatia [8] developed a speed control system that relies on temperature fluctuations. To build the hardware and simulate it on the computer, PWM and simulation tools were utilized. Wellem et al. [9] used an Atmel Atmega 8385 system and an LM35 temperature sensor to evaluate a temperature monitoring technique. Asraf [10] developed a PID controller and implemented it using National Instruments' LabVIEW virtual laboratory environment. It was proposed that an Arduino-based hardware implementation would yield far more related and acceptable temperature management results. Sami et al. [11] used the PWM principle and utilized LCD monitors to display temperature readings. Okpagu and Nwosu [12] constructed a temperature control system for egg incubators with the aid of PID controllers, DC motors, sensors, a fan control system, and LCDs. This is a critical sort of incubator system since it is necessary to monitor the embryo's growth and development; hence control and monitoring of temperature values were crucial in this system. Devi and Kalnar [13] employed temperature sensors to manage the drying chamber's atmosphere. The exhaust fan began to run based on the chosen temperature, controlling the drying atmosphere.

In summarizing the previous literature, automatic temperature and humidity control, particularly autonomous monitoring, has not been addressed by researchers, focusing primarily on the temperature and humidity in question. We recommend an Arduino-controlled and hardware-based temperature and humidity control system, with online monitoring and measuring as the primary focus. The goal of this work is to design an autonomous system for managing fan speed and switching the auxiliary source (backup heater). The control system is integrated into the solar dryer and tested using an Arduino Uno board. The test findings are shown on an LCD screen. To control and ease the display of temperature and relative humidity, the control software is built-in Arduino IDE. This design is regarded as a user-friendly automatic temperature-controlled fan regulator that decreases energy consumption while also assisting in improving the drying rate, hence enhancing the solar dryer's efficiency and getting a nutritionally valuable output. This will certainly be reflected in maintaining the quality and freshness of the drying food. Finally, this paper can save power energy which only functions when the temperature around the food is below 60 °C.

1 Problem identification for the drying process

The most common errors made in solar drying are related to ignoring the factors that are critical in most drying operations; time, air temperature, air velocity (and air exchange). However, certain renewable energies, such as solar and wind have the drawback of only being available for a limited time. Because renewable energy is reliant on weather-related natural events such as wind, rain, and solar energy, it is difficult to manage. These sources are external factors that depend on weather conditions and are not controlled by them. Increasing or decreasing energy leads to:

1.1 Overheating

During normal drying, water is continuously removed from near the material's surface. As depicted in Figure 1, we will begin with moisture inside a slice of the material, then blast warm air over the surface moisture that is traveling to the surface of the material, which will subsequently be removed by evaporation and exit the drier as wet exhaust air.

Some sun dryers generate enough heat inside the drying chamber to cause harden the material being dried. This is due to insufficient ventilation and excessive warmth. Extremely high temperatures can quickly evaporate surface moisture. This dries the surface and prevents moisture from the inside of the material from diffusing outwards to it. As a result, a dry, sometimes leathery covering forms surrounding the substance. This layer then functions as a moisture barrier, preventing the moisture from escaping.

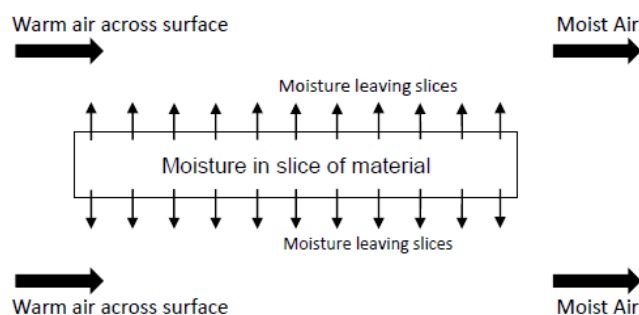

Fig.1. Normal drying process

After a period, the material will feel dry to the touch and have a leathery texture, giving the impression that it is completely dried. However, as seen in the figure, moisture trapped inside the material will eventually make its way to the top of the leathery layer, which will reverse the process as shown in Figure 2. Mold formation is a common side effect of storage or packing, and it can lead to major problems. Don't give in to the temptation to use too much heat to hasten the drying process.

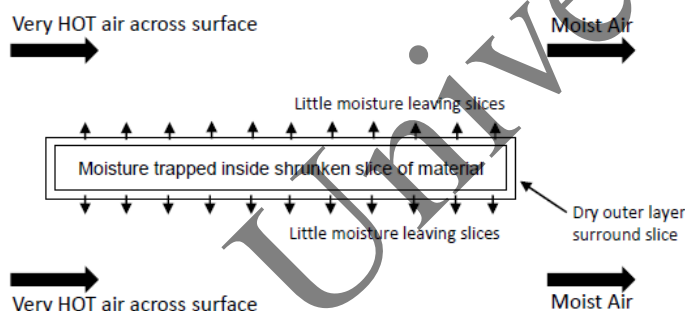

Fig.2. Excessive heating in the drying process

1.2 Poor heating

In the sun drying process of several agro-commodities, two separate transfer processes occur simultaneously, including heating the product and air and the mass transfer from the inside to the outside of the product, as well as drying medium through evaporation. Temperature, air velocity, and concentration differential all impact the passage of water and heat between the product and the drying air.

Heat and mass exchange between the material slice and the air is crucial throughout the drying process. As a result, there is no thermal transfer when the temperature of the air surrounding the product drops since there is no temperature differential between the product and the air. The mass diffuses down from a greater concentration to a lower concentration. As the temperature rises, moisture vaporizes off the material's surface and is released into the atmosphere. Low sun radiation and low air temperature within the drying chamber result in high relative humidity, which stops the drying process and causes the product to rot. As a result, to address the aforementioned problems, care should be made to preserve consistent drying air circulation and maintain a proper temperature within the dryer. This is accomplished via designing and constructing an automated system that online controls the temperature and humidity within the drying chamber, which is ideal for all weather conditions and the type of agricultural goods to be dried.

2 Hardware implementation

The system is divided into three stages. The first detects humidity and temperature using the DHT11 humidity and temperature sensor. The second component receives the output of the DHT sensor module and converts temperature and humidity readings into a useful percentage and Celsius scale number. The third portion of the system uses an LCD to display humidity and temperature. Single-wire serial communication is used to link the system. The Arduino first transmits a start signal to the DHT module, which is followed by a

response signal including temperature and humidity data from the DHT. The hardware system comprises the following components:

- [Arduino](#), Uno
- Motor Driver, L293D IC
- Sensor, DHT22
- Display, 16×2 [LCD](#)
- Fan motor, 12 V DC
- Battery, 12V
- Potentiometer, 2.2k Ω
- Relay, 5V DC
- Breadboard
- Back-up heater

Figure 3 displays the block diagram for the hardware implementation.

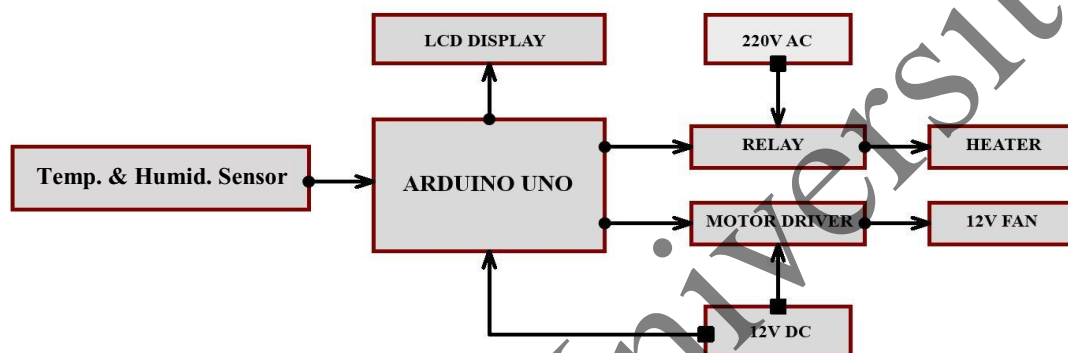

Fig.3. Block diagram of temperature and humidity control

2.1 Arduino UNO Board

Using Arduino UNO to collect the data from the sensors efficiently enables the system to control the indoor environment of the solar dryer based on the measured parameters. Arduino boards come in a variety of shapes and sizes, including the Arduino Yun, Arduino Mega, Arduino Nano, Pro Mini, and others. However, the Arduino Uno is the most well-known. It is used to regulate the entire solar dryer operation. The microcontroller board called UNO uses the ATmega328P. On this board, there are six analog inputs, a 16 MHz quartz crystal, six analog outputs, a USB connection, an ICSP header, a power connector, and a reset button. There are also 14 pins for digital input and output (six of which may be utilized as PWM outputs). Everything required for getting started with the microcontroller is included; all you have to do is connect it to a computer using the USB port or power it using a battery or an AC-to-DC converter.

2.2 DHT22 Temperature and Humidity sensor

A DHT22 sensor measures the temperature, which is used to control the fan speed. Relative humidity can also be detected, which is used to control the fan speed. Relative humidity can also be detected. This sensor comes in a 4-pin single-row device and has an integrated resistive-type humidity measuring component, an NTC-type temperature measurement element, and an 8-bit microcontroller with a quick reaction time. The serial communication method used by the DHT22 module is also referred to as "single-wire communication." As contrasted with other sensors, this one is incredibly user-friendly and extremely accurate. This module transmits data as a pulse train for a predetermined period. It requires certain initialization commands with a time delay before transferring data to the Arduino. And the entire procedure takes roughly 4 milliseconds. To begin, the Arduino sends high to low start signals with an 18 sec delay to DHT22 to assure DHT detection. The Arduino then pulls up the data line and waits for the DHT to respond for 20-40 sec. When the DHT receives the start signal, it sends a low voltage level response signal to Arduino with an 80sec time delay.

DHT22 sensors are used in the dryer system to detect humidity and temperature inside the chambers. This data is received and interpreted by an Arduino MEGA microcontroller. When the exhaust fan eliminates extra moisture within the dryer chamber and the parameters do not reach the desired temperature limit, it

signals to regulate the temperature. The storage chamber's humidity is controlled by adjusting the fan speed based on the sensor's measurement.

2.3 L293D fan motor driver

An L293D motor driver IC combined with Arduino is used for controlling the exhausted DC fan motor. Two DC motors can be driven by this IC. The motor speed is controlled by providing signals according to the PWM technique [14]. The minimum and maximum temperature values can be adjusted in the program code according to the fan speed requirement. The fan speed is automatically the PWM controlled according to the chamber and that gives a lot more accuracy than the manual manner. To operate the DC motor fan, the suggested program adjusts five distinct parameters. If the temperature value is below 40°C, the fan will be turned off and information on the LCD will be shown. The DC fan will begin functioning at low speed if the temperature is between 40 and 45 °C (25 % duty cycle). The fan will also spin at a medium speed if the temperature becomes in the range of 45-50°C (50 % duty cycle). The fan will operate at high speed if the temperature is between 50°C and 55°C (75 % duty cycle). The fan will speed up to the maximum value if the temperature is more than or equal to 55°C (100 % duty cycle).

2.4 Liquid Crystal Display LCD

The information on temperature and humidity for the solar drying chamber is monitored using an LCD, which offers information while managing the temperature and humidity values inside the chamber. The temperature and humidity are displayed on the display, which is directly linked to Arduino in 4-bit mode, as shown in Figure 4. RS, EN, D4, D5, D6, and D7 pins of the LCD are linked to Arduino digital pins 2-7. A 5k pull-up resistor is also used to link a DHT11 sensor module to Arduino's digital pin 12.

2.5 Heating temperature controller

This Arduino is a good example of making an on-off type controller. The most basic type of temperature control device is an on-off controller. The device's output is either on or off, with no in-between condition. When the temperature exceeds the set point, an on-off controller will change the output. On-off control is commonly employed in systems that require precise control and can tolerate having the energy switched on.

3 Circuit Diagram

Figure 4 shows how to connect all of the essential components using Arduino and DHT22, as shown in the circuit design for temperature-based DC fan speed control and monitoring. The Arduino is the brain of the system, controlling all functions. An output voltage corresponding to the temperature in Celsius (centigrade) is provided by the precision IC DHT22. The operational humidity and temperature ranges are 0–100% relative humidity and 40–80 degrees Celsius, respectively. A digital signal is calibrated using the DHT22 sensor output. Its stability and dependability are guaranteed by a patented digital signal-gathering method, as well as temperature and humidity monitoring technology. The sensing devices are connected to the 8-bit single-chip microprocessor.

4 System Flowchart

The system flowchart depicts the device workflow in the drying system. Figure 5 shows the system flowchart for temperature and humidity monitoring. The backup heater and electric fan begin to run at the preset temperature and humidity, controlling the drying environment. The electric fan is automatically controlled to change the speed level according to temperature changes compared to the traditional dryer.

At first, when the temperature is less than 40°C, the fan will stop and the backup heater will work on, also when the temperature is higher than 40°C, the fan speed will rotate at a slow value, and at the same time the backup heater will turn off and when the temperature reaches 45°C, the fan will rotate at medium speed. When the temperature reaches 50°C, the fan speed will be high, and if the temperature increases to 55°C, the fan will rotate at the maximum speed. The same thing in the process of the temperature gradient downward, the fan will work according to the temperatures received from the sensor until the temperature is less than 40°C, the fan will turn off and the heating coil will turn on again.

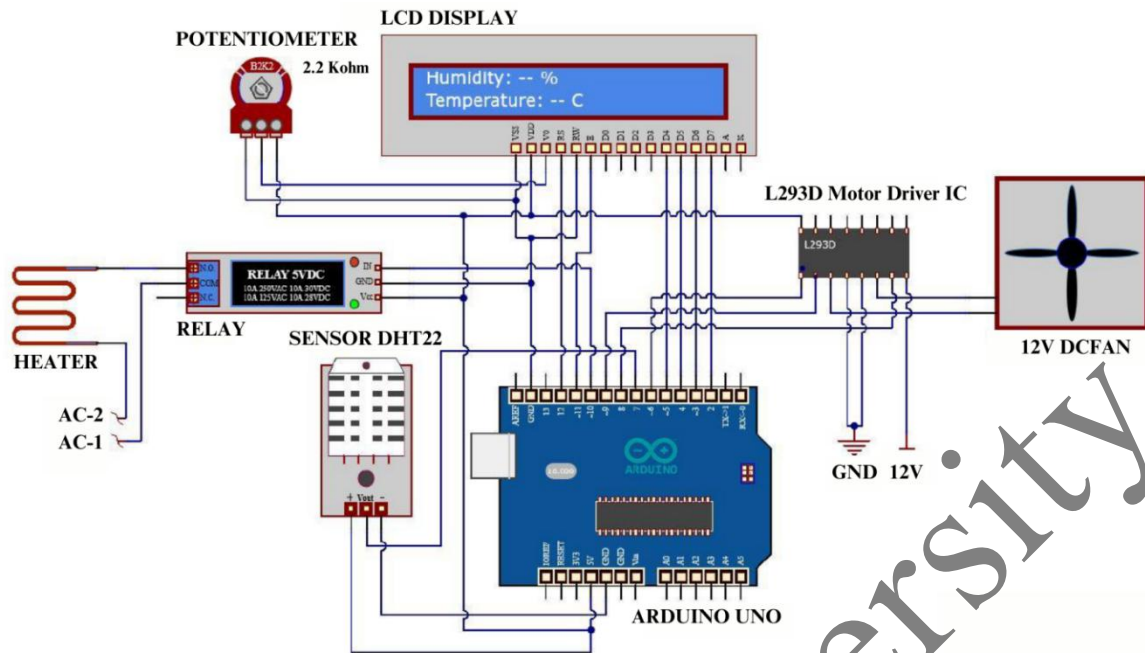

Fig.4. Circuit schematic of the proposed temperature-based DC fan speed control & backup heater

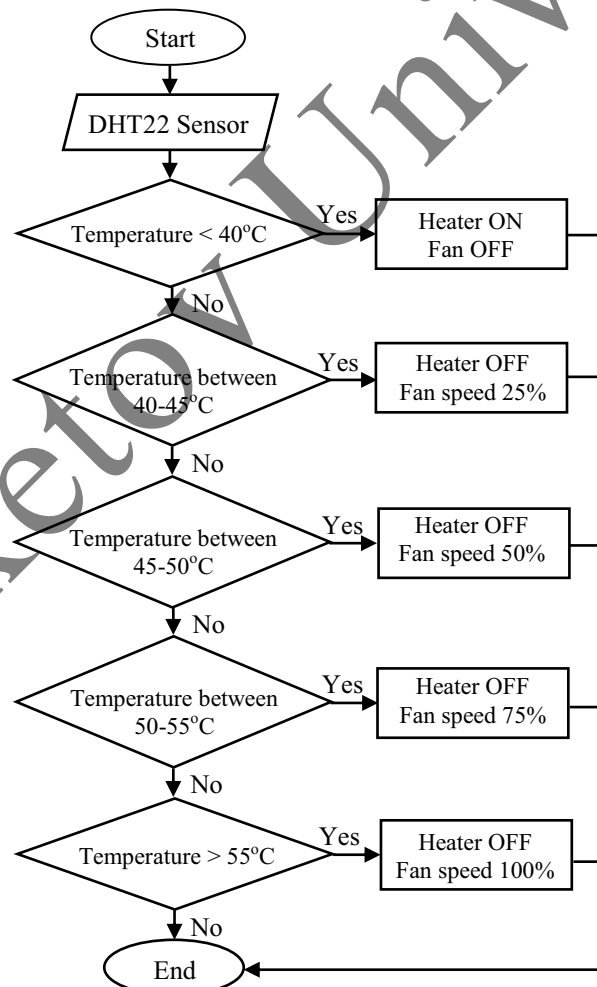

Fig.5. Monitoring system flowchart for temperature and humidity

The rotational speed of the fan depends on the rotational speed of the fan detected by the DHT22 sensor. The increase and decrease of temperatures depend on the intensity of the radiation when there is little or no solar radiation

5 Results and discussion

In the exhaust, a temperature sensor is fitted. The fan speed is controlled by the microcontroller via the temperature sensor, based on the specified desired temperature on the exhaust side. As a result, the temperature within the drying chamber is kept under control. The experimental setup was completed, and a large number of temperature measurements were recorded using the appropriate displays depicted in Figure 6. The illustration depicts how to connect the display to the board and Arduino hardware. In this work, the LCD online produces four readings: two of them are for automatically showing the temperature and humidity on the display. The third reading is for the duty cycle value of the PWM voltage to drive the DC motor fan at a suitable speed, and the fourth reading is for automatically switching ON/OFF the heater. The fan's operating state is determined by the pre-set threshold.

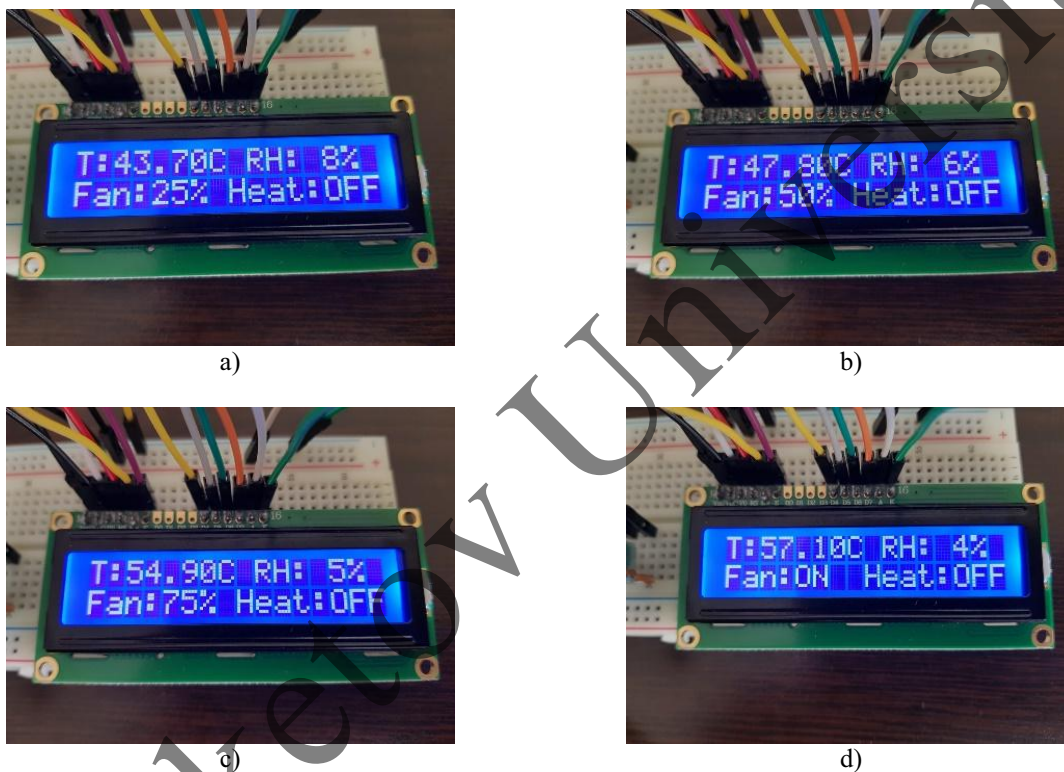

Fig.6. Display the temperature, relative humidity, and status of the DC fan in automatic control:

- a) lower range (40 – 45) °C; b) medium range (45 – 50) °C;
c) high range (50 – 55) °C; d) highest range more or equal 55°C.

The operational ranges for temperature and relative humidity are 40–60 °C and 0–100%, respectively. The management system was set up to maintain an ambient temperature between 40 and 60 °C and relative humidity between 10 and 20 %. In the first picture of Figure 6, the LCD demonstrates a temperature of 43.7 °C in the lower range of temperature which is between 40 °C and 45 °C at a relative humidity of 8% causing the controller to send a PWM voltage with a 25 % duty cycle to make the DC fan runs with low speed. Secondly, the LCD demonstrates a temperature of 47.8°C in the medium range of temperature between 45°C and 50°C at a relative humidity of 6% causing a 50 % duty cycle to make the DC fan run at medium speed. Thirdly, the LCD demonstrates a temperature of 54.9 °C in the high range of temperature, between 50°C and 55°C at a relative humidity of 5% causing a 75 % duty cycle to make the DC fan run at high speed.

The final picture of the figure shows the LCD findings temperature of 57.10 °C in the highest range which is more than or equal to 55 °C at a relative humidity of 4% causing a 100 % duty cycle to make the DC fan run at maximum speed.

The results of temperature and humidity and corresponding motor fan speeds can be demonstrated according to the following Table 1. From the findings, it can be deduced that the fan speed increases with dryer temperature and decreases with relative humidity in the chamber.

Table 1. Temperature and relative humidity monitoring and corresponding fan speed

Readings	Temperature (°C)	Relative humidity (%)	Duty cycle (%)	Fan speed
1	43.70	8	25	Low
2	47.80	6	50	Medium
3	54.90	5	75	High
4	57.10	4	100	Highest

Conclusions

The proposed developed system overcomes the defects of the traditional approach in the process of drying and managing products and maintains their quality and prevents spoilage. The key characteristics of this system include cost-effectiveness, portability, robustness, quick usage, and satisfactory performance under various circumstances.

The proposed design is seen as a built-in dryer with an easy-to-use automated fan regulator that is temperature controlled to reduce energy consumption while also aiding in speeding up the drying process, hence increasing the efficiency of the solar dryer and obtaining a nutritionally useful product. The food that is being dried will undoubtedly retain its quality and freshness as a result. As a last measure to save energy, this paper only works when the temperature around the product is 40–60°C.

Using an online monitoring system would improve the efficiency of drying and storing grains. The entire drying time, storage temperature, humidity, and real-time sensor data may all be noted by the observer.

This study contributes to the creation of automated methods for enhancing drying system performance, with the possibility of its use in agricultural products and medicinal herbs. It has been verified how this system works and how to encode a temperature-controlled fan. This method of managing simply temperature control automatically seems to be reliable. It might be made more reliable, and fuzzy regulated by using soft computing technologies.

The given theoretical analysis can be used to create a mathematical model of thermal heating of printed circuit boards (PCBs) in electronic devices and to analyze the heat emission from them caused by convection and radiation. During the operation of PCBs, when heating occurs, it may lead to some deformations such as twisting, bending, and delamination, which can be analyzed and predicted using the simulation results.

Funding

The study was supported by a grant from the Russian Science Foundation No. 22-19-00389, <https://rscf.ru/project/22-19-00389/>.

REFERENCES

- 1 Mohana Y., Mohanapriya R., Anukiruthika T., Yoha K.S., Moses J.A., Anandharamkrishnan C. Solar dryers for food applications: Concepts, designs, and recent advances. *Solar Energy*, 2020, Vol. 208, pp. 321–344. doi: 10.1016/j.solener.2020.07.098
- 2 Alkahdery L.A., Yurchenko A.V., Mohammed J.A.-K., Mekhtiyev A.D., Neshina Y.G. Performance Improvement of Solar Dryer using an Auxiliary Heat Source under Different Values of Airflow Rates. *Eurasian Physical Technical Journal*, 2023, Vol. 20, No. 1(43), pp. 42–50. doi:10.31489/2023No1/42-50
- 3 Abed E.M. Design and Testing Solar Dryer Performance. *Eng. and Tech. J.*, 2013, Vol. 31, No. 12, pp. 169–184. doi: 10.30684/etj.31.12A.14
- 4 Jadallah A.A., Alsaadi M.K., Hussien S.A. The Hybrid (PVT) Double-Pass System with a Mixed-Mode Solar Dryer for Drying Banana. *Eng. and Tech. J.*, 2020, Vol. 38, No. 8, pp. 1214–1225. doi: 10.30684/etj.v38i8A.535
- 5 Abdullah R., Rizman Z.I., Dzulkefli N.N.S.N., Ismail S., Shafie R., Jusoh M.H. Design an Automatic Temperature Control System for Smart Tudung Saji Using Arduino Microcontroller. *ARPJ Journal of Engineering and Applied Sciences*, 2016, Vol. 11, No. 16, pp. 9578–9581.

- 6 Widhiada W., Negara D.N.K.P., Suryawanm P.A. Temperature Distribution Control for Baby Incubator System Using Arduino ATmega 2560. *Bali Indonesia*, 2017, Vol. 19, No. 10 part xv, pp. 1748–1751.
- 7 Kesarwani K., Pranav S.M., Noah T.N., Kavitha K.V.N. Design of Temperature Based Speed Control System Using Arduino Microcontroller. *Int. J. Chem. Sci.*, 2016, Vol. 14 (S3), pp. 753–760.
- 8 Bhatia V., Bhatia G. Room Temperature based Fan Speed Control System using Pulse Width Modulation Technique. *International Journal of Computer Applications*, 2013, Vol. 81, No. 5, pp. 35–40. doi:10.5120/14011-2067
- 9 Wellem T., Setiawan B.A Microcontroller—Based Room Temperature Monitoring System. *International Journal of Computer Applications*, 2012, Vol. 53, No. 1, pp. 7–10. doi:10.5120/8383-1984
- 10 Asraf H.M., Dalila K.A.N., Hakim A.W.M., Hon R.H.M.F. Development of Experimental Simulator via Arduino-based PID Temperature Control System using LabVIEW. *Journal of Telecommunication, Electronic and Computer Engineering*, 2017, Vol. 9, No. 1–5, pp. 53–57.
- 11 Sami K., Lavanya M., Arivalagan M., Harsha Y.S. Temperature Controlled Based Cooler Pad Using Arduino. *Journal of Chemical and Pharmaceutical Sciences*, 2016, No. 5, pp. 216–220.
- 12 Okpagu P.E., Nwosu A.W. Development and temperature control of smart egg incubator system for various types of egg. *European J. of Eng. and Tech.*, 2016, Vol. 4, No. 2, pp. 13-21.
- 13 Devi T.H.B., Kalnar Y.B. Design Consideration of Smart Solar Dryer for Precision Drying. *Journal of AgriSearch.*, 2021, Vol. 8, No. 2, pp. 135-138. doi:10.21921/jas.v8i2.7297
- 14 Mohammed, J.A.-K. Pulse Width Modulation for DC Motor Control Based on LM324. *Eng. and Tech. J.*, 2013, Vol. 31, No. 10, pp. 1882-1896. doi:10.30684/etj.31.10A6

Article accepted for publication 06.04.2023

Buketov University