

M.T. Kosmakova<sup>1</sup>, V.G. Romanovski<sup>2</sup>, D.M. Akhmanova<sup>1</sup>,  
Zh.M. Tuleutaeva<sup>1,3</sup>, A.Yu. Bartashevich<sup>1</sup>

<sup>1</sup>*Buketov Karaganda state university, Kazakhstan;*

<sup>2</sup>*University of Maribor, Maribor, Slovenia;*

<sup>3</sup>*Karaganda state technical university, Kazakhstan*

(E-mail: svetlanamir578@gmail.com)

## On the solution to a two-dimensional boundary value problem of heat conduction in a degenerating domain

The article considers a homogeneous boundary-value problem for the heat equation in the non-cylindrical domain, namely, in an inverted pyramid with a vertex at the origin of coordinates, two faces of which lie in coordinate planes. A solution to the problem is sought in the form of a sum of generalized thermal potentials. There is a need to study the system of two Volterra integral equations of the second kind with singularities of the kernel. It is assumed that densities (heat intensity) depend only on a time variable, i.e. the density in each time section is considered constant. As a result, the system of integral equations is reduced to the homogeneous Volterra integral equation of the second kind. It is shown that this equation is uniquely solvable in the class of continuous functions.

*Keywords:* equation of heat conduction, Volterra integral equation, degenerating domain, thermal potential.

### Introduction

It is shown [1–3] that solving a homogeneous problem for the heat equation in the angular domain  $G = \{(x; t) : t > 0, 0 < x < t\}$  is reduced to solving the Volterra integral equation of the second kind with a kernel

$$K(t, \tau) = \frac{1}{2a\sqrt{\pi}} \left\{ \frac{t+\tau}{(t-\tau)^{\frac{3}{2}}} \exp\left(-\frac{(t+\tau)^2}{4a^2(t-\tau)}\right) + \frac{1}{(t-\tau)^{\frac{1}{2}}} \exp\left(-\frac{t-\tau}{4a^2}\right) \right\}. \quad (1)$$

In these Refs, as well as in Refs [4–5] it is shown that the kernels of the integral equations are “incompressible”, that is, the norm of the integral operator acting in the class of continuous functions is equal to unity.

In all works, the boundary of the domain moves at a constant velocity. Attempts to study the solvability of boundary value problems for the heat equation in non-cylindrical domains with a variable velocity of changing the boundary were made in works [6].

We also note that boundary value problems for a spectrally loaded parabolic equation reduce to this kind of singular integral equations, when the load line moves according to the law  $x = t$  or  $x^2 = t$  [7–11] and problems for essentially loaded equation of heat conduction [12].

In Ref [13] we have also investigated the Volterra integral equation with a singular kernel that differ from kernel (1). A norm of an integral operator acting in classes of continuous functions is equal to 3 [14].

In [15], the two-dimensional Dirichlet problem for the heat equation with respect to the spatial variable in an infinite dihedral angle was also considered. Using the Fourier transformation, the problem was reduced to a one-dimensional boundary value problem with the parameter. In [16] the boundary value problem for the heat equation was considered in an inverted cone. Assuming that the isotropy property is fulfilled in the angular coordinate (axial symmetry), we have studied the problem for the heat equation in polar coordinates, to which the two-dimensional problem in the spatial variable is reduced.

Now we are studying a homogeneous boundary value problem for the heat equation in the non-cylindrical domain, namely, in an inverted pyramid with a vertex at the origin of coordinates. As in papers [1–16], the boundary value problem of heat equation is considered in a degenerating domain, and the problem is also reduced to the Volterra integral equation. But a kernel of the obtained integral equation is differs from those considered by us earlier.

1 Formulation of the problem

In the domain (Fig. 1)  $Q = \{(x, y, t), (x, y) \in D; t > 0\}$ , we consider a problem: find a solution to the equation

$$\frac{\partial u}{\partial t} - a^2 \left( \frac{\partial^2 u}{\partial x^2} + \frac{\partial^2 u}{\partial y^2} \right) = 0, \tag{2}$$

satisfying the condition on a lateral surface of the pyramid:

$$u|_{\Gamma} = 0. \tag{3}$$

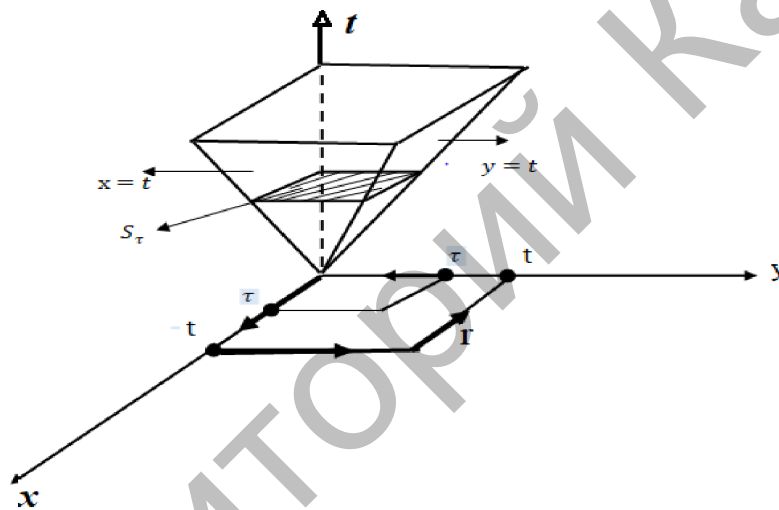

Figure 1. Domain Q

where  $D = \{(x, y), 0 < x < t, 0 < y < t\}, \partial D = \Gamma$ , (Fig. 2)

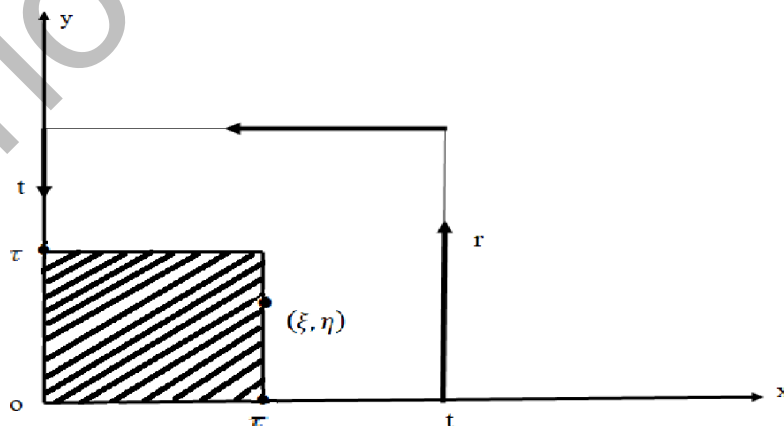

Figure 2. Domain D

2 Reducing the boundary value problem to a system of Volterra integral equations

We seek a solution to problem (2)–(3) using thermal potentials.

As is known, the thermal potential of the double layer has the form [17]:

$$W(x, y; t) = \frac{1}{2\pi} \int_0^t d\tau \int_{\Gamma} \frac{\psi(\sigma, \tau)}{t - \tau} \cdot \frac{\partial}{\partial \bar{n}} \exp\left(-\frac{r^2}{4a^2(t - \tau)}\right) d\sigma, \quad (4)$$

where an arc length  $\sigma$  of the contour  $\Gamma$  is counted from some fixed point, and  $\psi(\sigma, \tau)$  is a density (intensity) is a function of a variable point  $\sigma = (\xi, \eta)$  of the contour  $\Gamma$  and of the parameter  $\tau$ .

$r = \sqrt{(x - \xi)^2 + (y - \eta)^2}$  indicates the distance from the point  $(x, y)$  to a variable point  $\sigma$  of the contour  $\Gamma$ ,  $\bar{n}$  is a direction of the external normal at the variable integration point. It's obvious that  $W(x, y; t)$  satisfies the heat equation (2).

We will seek a solution to problem (2)–(3) in the form of a sum of generalized thermal potentials

$$\begin{aligned} u(x, y, t) = & \frac{1}{4a^2\pi} \int_0^t d\tau \int_0^\tau \frac{x}{(t - \tau)^2} \exp\left(-\frac{x^2 + (y - \eta)^2}{4a^2(t - \tau)}\right) \mu_1(\eta, \tau) d\eta + \\ & + \frac{1}{4a^2\pi} \int_0^t d\tau \int_0^\tau \frac{x - \tau}{(t - \tau)^2} \exp\left(-\frac{(x - \tau)^2 + (y - \eta)^2}{4a^2(t - \tau)}\right) \mu_2(\eta, \tau) d\eta + \\ & + \frac{1}{4a^2\pi} \int_0^t d\tau \int_0^\tau \frac{y}{(t - \tau)^2} \exp\left(-\frac{(x - \xi)^2 + y^2}{4a^2(t - \tau)}\right) \varphi_1(\xi, \tau) d\xi + \\ & + \frac{1}{4a^2\pi} \int_0^t d\tau \int_0^\tau \frac{y - \tau}{(t - \tau)^2} \exp\left(-\frac{(x - \xi)^2 + (y - \tau)^2}{4a^2(t - \tau)}\right) \varphi_2(\xi, \tau) d\xi, \end{aligned} \quad (5)$$

where  $\mu_i(x, y; t)$ ,  $\varphi_i(x, y; t)$ ,  $i = 1, 2$ , are functions to be defined.

Note that expression (5) follows from formula (4) by directly calculating the normal derivative.

We use the well-known property of the generalized thermal potential of a double layer [18].

The function  $W(x, y; t)$  is discontinuous at the contour  $\Gamma$ , and the following formulas hold:

$$\begin{aligned} W_i(x_0, y_0; t) = \lim_{(x,y) \rightarrow (x_0,y_0)} W_i(x_i, y_i; t) = W(x_0, y_0; t) + \frac{1}{2} \psi(x_0, y_0; t), \\ W_l(x_0, y_0; t) = \lim_{(x,y) \rightarrow (x_0,y_0)} W_l(x_l, y_l; t) = W(x_0, y_0; t) - \frac{1}{2} \psi(x_0, y_0; t), \end{aligned}$$

if  $\psi(x, y; t)$  is a continuous function, where  $(x_0, y_0)$  is a point of the boundary  $\Gamma$ , a point  $(x_i, y_i)$  lies inside the domain, and a point  $(x_l, y_l)$  lies outside the domain.

From the representation (5) and from the properties of the generalized thermal potential of the double layer, we obtain

$$\begin{aligned} \lim_{x \rightarrow 0+} u(x, y, t) = & \frac{1}{2} \mu_1(y, t) + \frac{1}{4a^2\pi} \int_0^t d\tau \int_0^\tau \frac{-\tau}{(t - \tau)^2} \exp\left(-\frac{\tau^2 + (y - \eta)^2}{4a^2(t - \tau)}\right) \mu_2(\eta, \tau) d\eta + \\ & + \frac{1}{4a^2\pi} \int_0^t d\tau \int_0^\tau \frac{y}{(t - \tau)^2} \exp\left(-\frac{\xi^2 + y^2}{4a^2(t - \tau)}\right) \varphi_1(\xi, \tau) d\xi + \\ & + \frac{1}{4a^2\pi} \int_0^t d\tau \int_0^\tau \frac{y - \tau}{(t - \tau)^2} \exp\left(-\frac{\xi^2 + (y - \tau)^2}{4a^2(t - \tau)}\right) \varphi_2(\xi, \tau) d\xi = 0. \end{aligned} \quad (6)$$

$$\begin{aligned} \lim_{x \rightarrow \tau-0} u(x, y, t) &= -\frac{1}{2}\mu_2(y, t) + \frac{1}{4a^2\pi} \int_0^t d\tau \int_0^\tau \frac{\tau}{(t-\tau)^2} \exp\left(-\frac{\tau^2 + (y-\eta)^2}{4a^2(t-\tau)}\right) \mu_1(\eta, \tau) d\eta + \\ &+ \frac{1}{4a^2\pi} \int_0^t d\tau \int_0^\tau \frac{y}{(t-\tau)^2} \exp\left(-\frac{(\tau-\xi)^2 + y^2}{4a^2(t-\tau)}\right) \varphi_1(\xi, \tau) d\xi + \\ &+ \frac{1}{4a^2\pi} \int_0^t d\tau \int_0^\tau \frac{y-\tau}{(t-\tau)^2} \exp\left(-\frac{(\tau-\xi)^2 + (y-\tau)^2}{4a^2(t-\tau)}\right) \varphi_2(\xi, \tau) d\xi = 0. \end{aligned} \quad (7)$$

$$\begin{aligned} \lim_{y \rightarrow 0+} u(x, y, t) &= \frac{1}{2}\varphi_1(x, t) + \frac{1}{4a^2\pi} \int_0^t d\tau \int_0^\tau \frac{x}{(t-\tau)^2} \exp\left(-\frac{x^2 + \eta^2}{4a^2(t-\tau)}\right) \mu_1(\eta, \tau) d\eta + \\ &+ \frac{1}{4a^2\pi} \int_0^t d\tau \int_0^\tau \frac{x-\tau}{(t-\tau)^2} \exp\left(-\frac{(x-\tau)^2 + \eta^2}{4a^2(t-\tau)}\right) \mu_2(\eta, \tau) d\eta + \\ &+ \frac{1}{4a^2\pi} \int_0^t d\tau \int_0^\tau \frac{-\tau}{(t-\tau)^2} \exp\left(-\frac{(x-\xi)^2 + \tau^2}{4a^2(t-\tau)}\right) \varphi_2(\xi, \tau) d\xi = 0. \end{aligned} \quad (8)$$

$$\begin{aligned} \lim_{y \rightarrow \tau-0} u(x, y, t) &= -\frac{1}{2}\varphi_2(x, t) + \frac{1}{4a^2\pi} \int_0^t d\tau \int_0^\tau \frac{x}{(t-\tau)^2} \exp\left(-\frac{x^2 + (\tau-\eta)^2}{4a^2(t-\tau)}\right) \mu_1(\eta, \tau) d\eta + \\ &+ \frac{1}{4a^2\pi} \int_0^t d\tau \int_0^\tau \frac{x-\tau}{(t-\tau)^2} \exp\left(-\frac{(x-\tau)^2 + (\tau-\eta)^2}{4a^2(t-\tau)}\right) \mu_2(\eta, \tau) d\eta + \\ &+ \frac{1}{4a^2\pi} \int_0^t d\tau \int_0^\tau \frac{\tau}{(t-\tau)^2} \exp\left(-\frac{(x-\xi)^2 + \tau^2}{4a^2(t-\tau)}\right) \varphi_1(\xi, \tau) d\xi = 0. \end{aligned} \quad (9)$$

We get a system of four equations with four unknown functions.

If into equations (8) and (9) the variable  $x$  is replaced by the variable  $y$  and the integration variable  $\xi$  is replaced by  $\eta$ , then we get that these equations coincide with equations (6) and (7), and  $\mu_i(y, t) = \varphi_i(y, t)$ , ( $i = 1, 2$ ).

Thus, it is possible to solve a system of two equations with two unknown functions  $\mu_1(y, t)$  and  $\mu_2(y, t)$ . For this, it is enough into equations (6) and (7) to replace the integration variable  $\xi$  with the variable  $\eta$  and to replace  $\varphi_i(\eta, \tau)$ , respectively, with  $\mu_i(\eta, \tau)$ , ( $i = 1, 2$ ).

As a result, we get:

$$\begin{aligned} \frac{1}{2}\mu_1(y, t) &= \frac{1}{4a^2\pi} \int_0^t d\tau \int_0^\tau \frac{\tau}{(t-\tau)^2} \exp\left(-\frac{\tau^2 + (y-\eta)^2}{4a^2(t-\tau)}\right) \mu_2(\eta, \tau) d\eta - \\ &- \frac{1}{4a^2\pi} \int_0^t d\tau \int_0^\tau \frac{y}{(t-\tau)^2} \exp\left(-\frac{\eta^2 + y^2}{4a^2(t-\tau)}\right) \mu_1(\eta, \tau) d\eta - \\ &- \frac{1}{4a^2\pi} \int_0^t d\tau \int_0^\tau \frac{y-\tau}{(t-\tau)^2} \exp\left(-\frac{\eta^2 + (y-\tau)^2}{4a^2(t-\tau)}\right) \mu_2(\eta, \tau) d\eta, \end{aligned} \quad (10)$$

$$\begin{aligned} \frac{1}{2}\mu_2(y, t) &= \frac{1}{4a^2\pi} \int_0^t d\tau \int_0^\tau \frac{\tau}{(t-\tau)^2} \exp\left(-\frac{\tau^2 + (y-\eta)^2}{4a^2(t-\tau)}\right) \mu_1(\eta, \tau) d\eta + \\ &+ \frac{1}{4a^2\pi} \int_0^t d\tau \int_0^\tau \frac{y}{(t-\tau)^2} \exp\left(-\frac{(\tau-\eta)^2 + y^2}{4a^2(t-\tau)}\right) \mu_1(\eta, \tau) d\eta + \\ &+ \frac{1}{4a^2\pi} \int_0^t d\tau \int_0^\tau \frac{y-\tau}{(t-\tau)^2} \exp\left(-\frac{(\tau-\eta)^2 + (y-\tau)^2}{4a^2(t-\tau)}\right) \mu_2(\eta, \tau) d\eta. \end{aligned} \quad (11)$$

## 3 Case of a constant density (intensity) of heat propagation

We assume the following.

Let the densities (heat intensity)  $\mu_1(\eta, \tau)$  and  $\mu_2(\eta, \tau)$  not depend on the first variable, i.e. the density in each section  $S_\tau$  (Fig. 2) are constant (and depends only on the variable  $\tau$ ), then we write equations (10) and (11) in the form:

$$\begin{aligned} \frac{1}{2}\mu_1(y, t) &= \frac{1}{2a\sqrt{\pi}} \int_0^t \frac{\tau}{(t-\tau)^{3/2}} \exp\left(-\frac{\tau^2}{4a^2(t-\tau)}\right) \mu_2(\tau) \left\{ \frac{1}{2a\sqrt{\pi}} \int_0^\tau \frac{\exp\left(-\frac{(y-\eta)^2}{4a^2(t-\tau)}\right)}{\sqrt{t-\tau}} d\eta \right\} d\tau - \\ &- \frac{1}{2a\sqrt{\pi}} \int_0^t \frac{y}{(t-\tau)^{3/2}} \exp\left(-\frac{y^2}{4a^2(t-\tau)}\right) \mu_1(\tau) \left\{ \frac{1}{2a\sqrt{\pi}} \int_0^\tau \frac{\exp\left(-\frac{\eta^2}{4a^2(t-\tau)}\right)}{\sqrt{t-\tau}} d\eta \right\} d\tau - \\ &- \frac{1}{2a\sqrt{\pi}} \int_0^t \frac{y-\tau}{(t-\tau)^{3/2}} \exp\left(-\frac{(y-\tau)^2}{4a^2(t-\tau)}\right) \mu_2(\tau) \left\{ \frac{1}{2a\sqrt{\pi}} \int_0^\tau \frac{\exp\left(-\frac{\eta^2}{4a^2(t-\tau)}\right)}{\sqrt{t-\tau}} d\eta \right\} d\tau. \end{aligned} \quad (12)$$

$$\begin{aligned} \frac{1}{2}\mu_2(y, t) &= \frac{1}{2a\sqrt{\pi}} \int_0^t \frac{\tau}{(t-\tau)^{3/2}} \exp\left(-\frac{\tau^2 + (y-\eta)^2}{4a^2(t-\tau)}\right) \mu_1(\tau) \left\{ \frac{1}{2a\sqrt{\pi}} \int_0^\tau \frac{\exp\left(-\frac{(y-\eta)^2}{4a^2(t-\tau)}\right)}{\sqrt{t-\tau}} d\eta \right\} d\tau + \\ &+ \frac{1}{2a\sqrt{\pi}} \int_0^t \frac{y}{(t-\tau)^{3/2}} \exp\left(-\frac{y^2}{4a^2(t-\tau)}\right) \mu_1(\tau) \left\{ \frac{1}{2a\sqrt{\pi}} \int_0^\tau \frac{\exp\left(-\frac{(\tau-\eta)^2}{4a^2(t-\tau)}\right)}{\sqrt{t-\tau}} d\eta \right\} d\tau + \\ &+ \frac{1}{2a\sqrt{\pi}} \int_0^t \frac{y-\tau}{(t-\tau)^{3/2}} \exp\left(-\frac{(y-\tau)^2}{4a^2(t-\tau)}\right) \mu_2(\tau) \left\{ \frac{1}{2a\sqrt{\pi}} \int_0^\tau \frac{\exp\left(-\frac{(\tau-\eta)^2}{4a^2(t-\tau)}\right)}{\sqrt{t-\tau}} d\eta \right\} d\tau. \end{aligned} \quad (13)$$

We calculate the internal integrals in (12) and (13).

$$\begin{aligned} \frac{1}{2a\sqrt{\pi}} \int_0^\tau \frac{1}{\sqrt{t-\tau}} \exp\left(-\frac{(y-\eta)^2}{4a^2(t-\tau)}\right) d\eta &= \left\| z = \frac{y-\eta}{2a\sqrt{t-\tau}}; dz = -\frac{d\eta}{2a\sqrt{t-\tau}} \right\| = \\ &= \frac{1}{\sqrt{\pi}} \int_{\frac{y-\tau}{2a\sqrt{t-\tau}}}^{\frac{y}{2a\sqrt{t-\tau}}} e^{-z^2} dz = \frac{1}{2} \left[ \operatorname{erf}\left(\frac{y}{2a\sqrt{t-\tau}}\right) - \operatorname{erf}\left(\frac{y-\tau}{2a\sqrt{t-\tau}}\right) \right]; \\ \frac{1}{2a\sqrt{\pi}} \int_0^\tau \frac{1}{\sqrt{t-\tau}} \exp\left(-\frac{\eta^2}{4a^2(t-\tau)}\right) d\eta &= \left\| z = \frac{\eta}{2a\sqrt{t-\tau}}; dz = \frac{d\eta}{2a\sqrt{t-\tau}} \right\| = \\ &= \frac{1}{\sqrt{\pi}} \int_0^{\frac{\tau}{2a\sqrt{t-\tau}}} e^{-z^2} dz = \frac{1}{2} \operatorname{erf}\left(\frac{\tau}{2a\sqrt{t-\tau}}\right); \\ \frac{1}{2a\sqrt{\pi}} \int_0^\tau \frac{1}{\sqrt{t-\tau}} \exp\left(-\frac{(\tau-\eta)^2}{4a^2(t-\tau)}\right) d\eta &= \left\| z = \frac{\tau-\eta}{2a\sqrt{t-\tau}}; dz = -\frac{d\eta}{2a\sqrt{t-\tau}} \right\| = \\ &= \frac{1}{\sqrt{\pi}} \int_0^{\frac{\tau}{2a\sqrt{t-\tau}}} e^{-z^2} dz = \frac{1}{2} \operatorname{erf}\left(\frac{\tau}{2a\sqrt{t-\tau}}\right). \end{aligned}$$

Substituting these values into (12)–(13), we have:

$$\frac{1}{2}\mu_1(y, t) = \frac{1}{4a\sqrt{\pi}} \int_0^t \frac{\tau}{(t-\tau)^{3/2}} \exp\left(-\frac{\tau^2}{4a^2(t-\tau)}\right) \left[ \operatorname{erf}\left(\frac{y}{2a\sqrt{t-\tau}}\right) + \operatorname{erf}\left(\frac{y-\tau}{2a\sqrt{t-\tau}}\right) \right] \mu_2(\tau) d\tau$$

$$\begin{aligned}
 & -\frac{1}{4a\sqrt{\pi}} \int_0^t \frac{y}{(t-\tau)^{3/2}} \exp\left(-\frac{y^2}{4a^2(t-\tau)}\right) \operatorname{erf}\left(\frac{\tau}{2a\sqrt{t-\tau}}\right) \mu_1(\tau) d\tau - \\
 & -\frac{1}{4a\sqrt{\pi}} \int_0^t \frac{y-\tau}{(t-\tau)^{3/2}} \exp\left(-\frac{(y-\tau)^2}{4a^2(t-\tau)}\right) \operatorname{erf}\left(\frac{\tau}{2a\sqrt{t-\tau}}\right) \mu_2(\tau) d\tau; \tag{14}
 \end{aligned}$$

$$\begin{aligned}
 \frac{1}{2}\mu_2(y, t) &= \frac{1}{4a\sqrt{\pi}} \int_0^t \frac{\tau}{(t-\tau)^{3/2}} \exp\left(-\frac{\tau^2}{4a^2(t-\tau)}\right) \left[ \operatorname{erf}\left(\frac{y}{2a\sqrt{t-\tau}}\right) + \operatorname{erf}\left(\frac{y-\tau}{2a\sqrt{t-\tau}}\right) \right] \mu_1(\tau) d\tau + \\
 & + \frac{1}{4a\sqrt{\pi}} \int_0^t \frac{y}{(t-\tau)^{3/2}} \exp\left(-\frac{y^2}{4a^2(t-\tau)}\right) \operatorname{erf}\left(\frac{\tau}{2a\sqrt{t-\tau}}\right) \mu_1(\tau) d\tau - \\
 & + \frac{1}{4a\sqrt{\pi}} \int_0^t \frac{y-\tau}{(t-\tau)^{3/2}} \exp\left(-\frac{(y-\tau)^2}{4a^2(t-\tau)}\right) \operatorname{erf}\left(\frac{\tau}{2a\sqrt{t-\tau}}\right) \mu_2(\tau) d\tau. \tag{15}
 \end{aligned}$$

Since we assumed that the heat intensity (density) depends only on the variable  $t$ , then in equalities (14), (15) the variable  $y$  must be considered equal  $t$

$$\begin{aligned}
 \mu_1(t) &= \frac{1}{2a\sqrt{\pi}} \int_0^t \frac{\tau}{(t-\tau)^{3/2}} \exp\left(-\frac{\tau^2}{4a^2(t-\tau)}\right) \left[ \operatorname{erf}\left(\frac{t}{2a\sqrt{t-\tau}}\right) + \operatorname{erf}\left(\frac{\sqrt{t-\tau}}{2a}\right) \right] \mu_2(\tau) d\tau - \\
 & - \frac{1}{2a\sqrt{\pi}} \int_0^t \frac{t}{(t-\tau)^{3/2}} \exp\left(-\frac{t^2}{4a^2(t-\tau)}\right) \operatorname{erf}\left(\frac{\tau}{2a\sqrt{t-\tau}}\right) \mu_1(\tau) d\tau - \\
 & - \frac{1}{2a\sqrt{\pi}} \int_0^t \frac{1}{(t-\tau)^{3/2}} \exp\left(-\frac{t-\tau}{4a^2}\right) \operatorname{erf}\left(\frac{\tau}{2a\sqrt{t-\tau}}\right) \mu_2(\tau) d\tau; \tag{16}
 \end{aligned}$$

$$\begin{aligned}
 \mu_2(t) &= \frac{1}{2a\sqrt{\pi}} \int_0^t \frac{\tau}{(t-\tau)^{3/2}} \exp\left(-\frac{\tau^2}{4a^2(t-\tau)}\right) \left[ \operatorname{erf}\left(\frac{t}{2a\sqrt{t-\tau}}\right) + \operatorname{erf}\left(\frac{\sqrt{t-\tau}}{2a}\right) \right] \mu_1(\tau) d\tau + \\
 & + \frac{1}{2a\sqrt{\pi}} \int_0^t \frac{t}{(t-\tau)^{3/2}} \exp\left(-\frac{t^2}{4a^2(t-\tau)}\right) \operatorname{erf}\left(\frac{\tau}{2a\sqrt{t-\tau}}\right) \mu_1(\tau) d\tau + \\
 & + \frac{1}{2a\sqrt{\pi}} \int_0^t \frac{1}{(t-\tau)^{3/2}} \exp\left(-\frac{t-\tau}{4a^2}\right) \operatorname{erf}\left(\frac{\tau}{2a\sqrt{t-\tau}}\right) \mu_2(\tau) d\tau. \tag{17}
 \end{aligned}$$

Adding the equations (16) and (17) we obtain the following homogeneous integral equation

$$\mu(t) - \int_0^t K(t, \tau) \mu(\tau) d\tau = 0, \tag{18}$$

where  $\mu(t) = \mu_1(t) + \mu_2(t)$ ,

$$K(t, \tau) = \frac{1}{2a\sqrt{\pi}} \frac{\tau}{(t-\tau)^{3/2}} \exp\left(-\frac{\tau^2}{4a^2(t-\tau)}\right) \left\{ \operatorname{erf}\left(\frac{t}{2a\sqrt{t-\tau}}\right) + \operatorname{erf}\left(\frac{\sqrt{t-\tau}}{2a}\right) \right\}.$$

Since

$$-\frac{\tau^2}{4a^2(t-\tau)} = -\frac{t-\tau}{4a^2} + \frac{t}{4a^2} - \frac{t-\tau}{4a^2(t-\tau)},$$

we rewrite the equation (18) in the form:

$$\psi(t) - \int_0^t K_1(t, \tau) \psi(\tau) d\tau = 0, \tag{19}$$

where

$$\psi(t) = \exp\left\{\frac{t}{4a^2}\right\} \mu(\tau),$$

$$K_1(t, \tau) = \frac{1}{2a\sqrt{\pi}} \exp\left\{\frac{t}{4a^2}\right\} \frac{\tau}{(t-\tau)^{3/2}} \exp\left\{-\frac{t\tau}{4a^2(t-\tau)}\right\} \left[ \operatorname{erf}\left(\frac{t}{2a\sqrt{t-\tau}}\right) + \operatorname{erf}\left(\frac{\sqrt{t-\tau}}{2a}\right) \right].$$

Let us estimate the integral

$$\int_0^t K_1(t, \tau) d\tau \geq 0.$$

$$0 \leq \int_0^t K_1(t, \tau) d\tau \leq \frac{1}{a\sqrt{\pi}} \exp\left(\frac{t}{4a^2}\right) J(t). \tag{20}$$

We introduce the replacement

$$z = \frac{t}{2a\sqrt{t-\tau}}, t-\tau = \frac{t^2}{4a^2z^2}, \tau = t - \frac{t^2}{4a^2z^2}, d\tau = \frac{t^2}{2a^2z^3} dz.$$

$$\frac{\tau}{t-\tau} = \left(t - \frac{t^2}{4a^2z^2}\right) \cdot \frac{4a^2z^2}{t^2} = \frac{4a^2}{t} \cdot z^2 - 1;$$

$$\tau = 0 \Rightarrow z = \frac{\sqrt{t}}{2a}; \quad \tau \rightarrow t \Rightarrow z \rightarrow +\infty.$$

Then

$$J(t) = \int_0^t \frac{\tau}{(t-\tau)^{3/2}} \exp\left\{-\frac{t\tau}{4a^2(t-\tau)}\right\} d\tau = \int_{\frac{\sqrt{t}}{2a}}^{+\infty} \left(t - \frac{t^2}{4a^2z^2}\right) \cdot \frac{8a^3z^3t^2}{t^3 \cdot 2a^2z^3} \times$$

$$\times \exp\left\{-\frac{t}{4a^2} \left(\frac{4a^2}{t}z^2 - 1\right)\right\} dz = 4at \cdot \exp\left\{\frac{t}{4a^2}\right\} \cdot \int_{\frac{\sqrt{t}}{2a}}^{+\infty} \left(1 - \frac{t}{4a^2} \cdot \frac{1}{z^2}\right) e^{-z^2} dz =$$

$$= 4at \cdot \exp\left\{\frac{t}{4a^2}\right\} \cdot \int_{\frac{\sqrt{t}}{2a}}^{+\infty} z^{-2} \left(z^2 - \frac{t}{4a^2}\right) e^{-z^2} dz = \left\| z^2 = x, z = \sqrt{x}, dz = \frac{dx}{\sqrt{x}} \right\| =$$

$$= 4at \cdot \exp\left\{\frac{t}{4a^2}\right\} \cdot \int_{\frac{t}{4a^2}}^{+\infty} x^{-\frac{3}{2}} \left(x - \frac{t}{4a^2}\right) \cdot e^{-x} dx.$$

We have used the formula 2.3.6(6) from [19], when

$$\left\| \begin{array}{l} \alpha = -\frac{1}{2}, \beta = 2, p = 1, \\ \alpha + \beta - 1 = \frac{1}{2}, \alpha + \beta = \frac{3}{2} \end{array} \right\|$$

Then

$$J(t) = 4at \cdot \exp\left\{\frac{t}{4a^2}\right\} \cdot \frac{\sqrt{t}}{2a} \cdot \exp\left\{-\frac{t}{4a^2}\right\} \cdot \psi\left(2; \frac{3}{2}; \frac{t}{4a^2}\right).$$

We use the formula 7.11.4.(8) from [20] and formula II.8 from [21]. Then

$$J(t) = 2t\sqrt{t}2^{\frac{3}{2}} \frac{2a}{\sqrt{t}} \exp\left(\frac{t}{8a^2}\right) \cdot D_{-3}\left(\frac{\sqrt{2}\sqrt{t}}{2a}\right) =$$

$$= 8\sqrt{2}at \exp\left(\frac{t}{8a^2}\right) \frac{1}{2} \exp\left(-\frac{t}{8a^2}\right) \frac{d}{dz} \left( \exp\left(\frac{z^2}{4}\right) \left\{ \frac{z}{2} \cdot \operatorname{erfc}\left(\frac{z}{\sqrt{2}}\right) - \frac{2}{\sqrt{2\pi}} \exp\left(-\frac{z^2}{2}\right) \right\} \right)_{z=\frac{\sqrt{2}\sqrt{t}}{2a}} =$$

$$= 4\sqrt{2}at \exp\left(\frac{z^2}{4}\right) \left\{ \frac{z^2}{4} \operatorname{erfc}\left(\frac{z}{\sqrt{2}}\right) - \frac{z}{\sqrt{2\pi}} \exp\left(-\frac{z^2}{4}\right) + \right.$$

$$\begin{aligned}
& \left. + \frac{1}{2} \operatorname{erfc} \left( \frac{z}{\sqrt{2}} \right) - \frac{z}{\sqrt{2\pi}} \exp \left( -\frac{z^2}{2} \right) + \frac{2z}{\sqrt{2\pi}} \exp \left( -\frac{z^2}{2} \right) \right\}_{z=\frac{\sqrt{2t}}{2a}} = \\
& = 4\sqrt{2} at \exp \left( \frac{t}{8a^2} \right) \left\{ \left( \frac{t}{8a^2} + \frac{1}{2} \right) \operatorname{erfc} \left( \frac{\sqrt{t}}{2a} \right) + \frac{\sqrt{t}}{a\sqrt{\pi}} \exp \left( -\frac{t}{4a^2} \right) \right\}.
\end{aligned}$$

Thus,

$$J(t) = 4\sqrt{2} at \exp \left( \frac{t}{8a^2} \right) \left\{ \left( \frac{t}{8a^2} + \frac{1}{2} \right) \cdot \operatorname{erfc} \left( \frac{\sqrt{t}}{2a} \right) + \frac{\sqrt{t}}{a\sqrt{\pi}} \exp \left( -\frac{t}{4a^2} \right) \right\} \quad (21)$$

We substitute the expression (21) into inequality (20):

$$\begin{aligned}
0 \leq \int_0^t K_1(t, \tau) d\tau \leq \frac{4\sqrt{2}}{a\sqrt{\pi}} \exp \left( \frac{t}{4a^2} \right) \cdot at \cdot \exp \left( \frac{t}{8a^2} \right) \cdot \left\{ \left( \frac{t}{8a^2} + \frac{1}{2} \right) \operatorname{erfc} \left( \frac{\sqrt{t}}{2a} \right) + \right. \\
\left. + \frac{\sqrt{t}}{a\sqrt{\pi}} \cdot \exp \left( -\frac{t}{4a^2} \right) \right\}
\end{aligned}$$

or

$$0 \leq \int_0^t K_1(t, \tau) d\tau \leq \frac{4\sqrt{2}}{\sqrt{\pi}} \cdot t \cdot \left( \left( \frac{t}{8a^2} + \frac{1}{2} \right) \exp \left\{ \frac{3t}{8a^2} \right\} \cdot \operatorname{erfc} \left( \frac{\sqrt{t}}{2a} \right) + \frac{\sqrt{t}}{a\sqrt{\pi}} \exp \left\{ \frac{t}{8a^2} \right\} \right). \quad (22)$$

Taking the limit at  $t \rightarrow 0$  from (22), we obtain

$$\lim_{t \rightarrow 0} \int_0^t K(t, \tau) = 0.$$

#### 4 Main results

Thus, the following lemma is proved.

*Lemma 1. Integral equation (19) has a unique solution  $\psi(t) \equiv 0$  in the class of continuous functions at  $t \in [0, T]$ ,  $0 < T < +\infty$ .*

Since

$$\psi(t) = \exp \left\{ \frac{t}{4a^2} \right\} \mu(\tau)$$

and  $\mu(t) = \mu_1(t) + \mu_2(t)$ , then the system of equations (16) – (17) is also uniquely solvable.

Further. The functions  $\mu_1(t)$  and  $\mu_2(t)$  are the density of thermal potentials under the assumption that the heat intensity (density) depends only on the variable  $t$ . Тогда из  $\psi(t) \equiv 0$  следует, что  $\mu_1(t) = \mu_2(t) \equiv 0$ .

*Lemma 2. Boundary value problem (2)–(3) in the domain  $Q$  is uniquely solvable at a constant density (intensity) of heat propagation.*

This study was financially supported by Committee of Science of the Ministry of Education and Sciences RK (Grant No. AP05132262).

#### References

- 1 Jenaliyev, M., Amangaliyeva, M., Kosmakova, M., & Ramazanov, M. (2014). About Dirichlet boundary value problem for the heat equation in the infinite angular domain. *Boundary Value Problems*, 213, 1–21. doi: 10.1186/s13661-014-0213-4

- 2 Amangaliyeva, M.M., Dzhenaliev, M.T., Kosmakova, M.T., & Ramazanov M.I. (2015). On one homogeneous problem for the heat equation in an infinite angular domain. *Siberian Mathematical Journal*, Vol. 56, No. 6, 982–995. DOI: 10.1134/S0037446615060038
- 3 Amangaliyeva, M.M., Jenaliyev, M.T., Kosmakova, M.T., & Ramazanov, M.I. (2015). Uniqueness and non-uniqueness of solutions of the boundary value problems of the heat equation. *AIP Conference Proceedings*, 1676, 020028. DOI: 10.1063/1.4930454
- 4 Amangaliyeva, M.M., Jenaliyev, M.T., Kosmakova, M.T., & Ramazanov, M.I. (2014). On the spectrum of Volterra integral equation with the "incompressible" kernel. *AIP Conference Proceedings*, 1611, 127-132. DOI: 10.1063/1.4893816
- 5 Amangaliyeva, M.M., Jenaliyev, M.T., Kosmakova, M.T., & Ramazanov, M.I. On a Volterra equation of the second kind with 'incompressible' kernel. *Advances in Difference Equations*, 71, 1–14. DOI: 10.1186/s13662-015-0418-6.
- 6 Kosmakova, M.T. (2016). On an integral equation of the Dirichlet problem for the heat equation in the degenerating domain. *Bulletin of the Karaganda University-Mathematics*, 1 (81), 62-67.
- 7 Amangaliyeva, M.M., Akhmanova, D.M., Dzhenaliev, M.T., & Ramazanov, M.I. (2011). Boundary value problems for a spectrally loaded heat operator with load line approaching the time axis at zero or infinity. *Differential Equations*, 47, 2, 231–243. DOI: 10.1134/S0012266111020091
- 8 Dzhenaliev, M.T., & Ramazanov, M.I. (2006). On the boundary value problem for the spectrally loaded heat conduction operator. *Siberian Mathematical Journal*, 47, 3, 433-451. DOI: 10.1007/s11202-006-0056-z
- 9 Dzhenaliev, M.T., & Ramazanov, M.I. (2007). On a boundary value problem for a spectrally loaded heat operator: I *Differential Equations*, 43, 4, 513-524. DOI: 10.1134/S0012266107040106
- 10 Dzhenaliev, M.T., & Ramazanov, M.I. (2007). On a boundary value problem for a spectrally loaded heat operator: II *Differential Equations*, 43, 6, 806-812. DOI: 10.1134/S0012266107060079
- 11 Akhmanova, D.M., Ramazanov, M.I., & Yergaliyev. M.G. (2018). On an integral equation of the problem of heat conduction with domain boundary moving by law of  $t = x^2$ . *Bulletin of the Karaganda University-Mathematics*, 1 (89), 15-19. DOI: 10.31489/2018M1/15-19.
- 12 Ramazanov, M.I., Kosmakova, M.T., Romanovsky, V.G., Zhanbusinova, B.H., & Tuleutaeva, Z.M. (2018). Boundary value problems for essentially-loaded parabolic equation. *Bulletin of the Karaganda University-Mathematics*, 4 (92), 79-86. DOI: 10.31489/2018M4/79-86
- 13 Kosmakova, M.T., Romanovski, V.G., Orumbayeva, N.T., Tuleutaeva, Zh.M., & Kasymova, L.Zh. (2019). On the integral equation of an adjoint boundary value problem of heat conduction. *Bulletin of the Karaganda University-Mathematics*, 3 (95), 33–43. doi: 10.31489/2019M2/33-43.
- 14 Kosmakova, M.T., Akhmanova, D.M., Tuleutaeva, Zh.M., & Kasymova, L.Zh. Solving a non-homogeneous integral equation with the variable lower limit. *Bulletin of the Karaganda University-Mathematics*, 4 (96), 52–57. doi: 10.31489/2019M4/52-57.
- 15 Kosmakova, M.T., Orumbayeva, N.T., Medeubaev, N.K., & Tuleutaeva, Zh.M. (2018). Problems of Heat Conduction with Different Boundary Conditions in Noncylindrical Domains. *AIP Conference Proceedings*, 1997, UNSP 020071-1. DOI: 10.1063/1.5049065
- 16 Kosmakova, M.T., Tanin, A.O. & Tuleutaeva, Zh.M. (2020). Constructing the fundamental solution to a problem of heat conduction. *Bulletin of the Karaganda University-Mathematics*, 1 (97), 68-78. DOI 10.31489/2020M1/68-78
- 17 Smirnov, V.I. (1964). *A Course of Higher Mathematics. Integral equations and partial differential equations*, Vol. 4, Part 2. Engl. transl. of 3-st ed. Pergamon Press: Oxford, [U.S.A. ed. distributed by Addison-Wesley Pub. Co., Reading, Mass.].
- 18 Tikhonov, A.N., & Samarskii, A.A. (2011). *Equations of the mathematical physics*. reprint edn., translated from the Russian by A.R.M Robson and P.Basu; Dover Publications: New York, USA.

- 19 Prudnikov, A.P., Brychkov, Yu.A., & Marichev, O.I. (1998). *Integrals and Series: Elementary Functions*. (N.M. Queen, Trans) CRC: New York, USA.
- 20 Prudnikov, A.P., Brychkov, Yu.A., & Marichev, O.I. (1989). *Integrals and Series: More Special Functions, Vol. 3*. Gordon and Breach: New York-London.
- 21 Prudnikov, A.P., Brychkov, Yu.A., & Marichev, O.I. (1998). *Integrals and Series: Special Functions, Vol. 2*. Taylor&Francis Ltd: London.

М.Т. Космакова, В.Г. Романовский, Д.М. Ахманова,  
Ж.М. Тулеутаева, А.Ю. Барташевич

### Жойылатын облыстағы жылуөткізгіштіктің екі өлшемді шеттік есебінің шешуіне

Жұмыста цилиндрлік емес облыстағы жылуөткізгіштік теңдеуі үшін біртекті шеттік есеп қарастырылған, оның ішінде, төбесі координаталар басы болатын, екі жағы координаталық жазықтықтарда жататын төңкерілген пирамида. Есеп шешуі жалпыланған жылу потенциалдарының қосындысы түрінде іздестірілген. Ядросының сингулярлығы бар екінші текті екі интегралды Вольтерр теңдеулер жүйесін зерттеу қажеттілігі туындайды. Тығыздық (жылу қарқындылығы) тек уақытша айнымалыға тәуелді деп болжанады, яғни әрбір уақытша қимадағы тығыздық тұрақты болып саналады. Нәтижесінде интегралдық теңдеулер жүйесі екінші текті Вольтердің біртекті интегралдық теңдеуіне келтірілген. Үздіксіз функциялар класында бұл теңдеудің тек бір ғана жолмен шешілетіні көрсетілген.

*Кілт сөздер:* жылу өткізгіштік теңдеуі, Вольтердің интегралдық теңдеуі, жойылатын облыс, жылу потенциалы.

М.Т. Космакова, В.Г. Романовский, Д.М. Ахманова,  
Ж.М. Тулеутаева, А.Ю. Барташевич

### К решению двумерной граничной задачи теплопроводности в вырождающейся области

В статье рассмотрена однородная краевая задача для уравнения теплопроводности в нецилиндрической области, а именно, в перевернутой пирамиде с вершиной в начале координат, две грани которой лежат в координатных плоскостях. Решение задачи ищется в виде суммы обобщенных тепловых потенциалов. Возникает необходимость исследования системы двух интегральных уравнений Вольтерра второго рода с сингулярностями ядра. Плотности (интенсивность тепла) предполагаются зависящими только от временной переменной, т.е. плотность в каждом временном сечении считается постоянной. В итоге система интегральных уравнений сведена к однородному интегральному уравнению Вольтерра второго рода. Показано, что это уравнение разрешимо единственным образом в классе непрерывных функций.

*Ключевые слова:* уравнение теплопроводности, интегральное уравнение Вольтерра, вырождающаяся область, тепловой потенциал.