

UDK 535.371, 535.374

EFFECT OF SILVER NANOPARTICLES ON GENERATION RHODAMINE 6G IN SOLUTION

Zeinidenov A.K., Ibrayev N.Kh., Mikhalovsky S.V., Aimukhanov A.K.

Institute of Molecular Nanophotonics, E.A. Buketov Karaganda State University, Universitetskaya str. 28, 100028, Karaganda, Kazakhstan, niazibraev@mail.ru

School of Pharmacy and Biomolecular Sciences, University of Brighton, Cockcroft Building, Lewes Road, Brighton BN2 4GJ, United Kingdom

The influence of silver nanoparticle on the spontaneous and stimulated luminescence of rhodamine 6G molecules in aqueous solution was studied. It was determined that under laser beam excitation of the dye solution appears the stimulated luminescence which with increase in laser pumping transforms in stimulated laser emission and superluminescence. In the presence of silver nanoparticle all kinds of emission amplification and the lasing threshold contraction of both types of stimulated emission have been observed. When measuring the emission spectra of solutions for "reflection" superluminescence of rhodamine 6G was found. Dependence of the lasing intensity and the superluminescence intensity on nanoparticle silver concentration correlates with spontaneous fluorescence data.

Keywords: Silver nanoparticles, localized plasmon resonance, Rhodamine 6G, lasing, super radiance.

Introduction

Researches related to the excitation of localized plasmon resonance of metal nanoparticles are intensively carried out in recent time [1,2]. Surface-enhanced Raman scattering is the most famous among the optical manifestations of localized plasmon resonance of nanoparticles of metals [3]. Molecules of luminophores placed near the surface of metal nanoparticles also undergo to the action of the local electro-magnetic fields. Thus, depending on the distance between the nanoparticles and molecule fluorescence of the past could be enhanced or quenched [4,5]. Mission could be quenched at close distances and direct contact of nanoparticles and fluorophores because of the predominance of the nonradiative energy transfer from fluorescent molecules to the nanoparticles.

Practically, interest in plasmonic effect is linked with the possibility of the creation of highly sensitive fluorescent sensors [6], optoelectronic devices [7], nanolasers [8], efficient photovoltaic cells [9], etc.

One of the promising areas of modern laser physics is the creation and study of composite media of laser-active molecules and metal nanoclusters [10]. There is information about that the addition of nanoparticles of metals in the active medium of dye lasers leads to the lowering in the generation threshold [11, 12, 13].

In this paper the effect of silver nanoparticles on the properties of induced lasing of Rhodamine 6G was studied in solutions.

Experiments

Nanoparticles (NPs) were prepared by the silver citrate recovery AgNO_3 in water solution [14].

During the preparation of a colloidal solution of silver nanoparticles deionized water obtained by the multi-stage filtration AquaMax 360 Basic was used. The specific resistance of the water was equal to 18.2 M Ω /cm.

The size of Ag nanoparticles in colloidal solutions was determined by dynamic light scattering analyzer of the sizes of submicron particles Zetasizer Nano ZS (Malvern). The average size of the silver particles was equal to 85 nm. The spread of the values of dispersibility of the silver particles is the minimal and ranges from 5 to 10 nm.

Measurements of the spectral and energy characteristics of induced emission of solutions of Rhodamine 6G were performed upon excitation of samples by second harmonic of Nd:YAG laser (1) (SOLAR LQ 215, $\lambda_{\text{gen}} = 532 \text{ nm}$, $E_{\text{imp}} = 90 \text{ mJ}$, $\tau = 10 \text{ ns}$) in the cross-version.

An optical resonator, which was formed by reflection mirror (6) and the front edge of the cell with a dye solution (7) were used at the measuring of the lasing properties. Pump radiation passing diaphragm (3) by the cylindrical lenses (4,5) was focused on the lateral face of the cell in the strip with area of 0.07 cm^2 . Generation of radiation arises in a narrow region near the wall of the front wall of the cell.

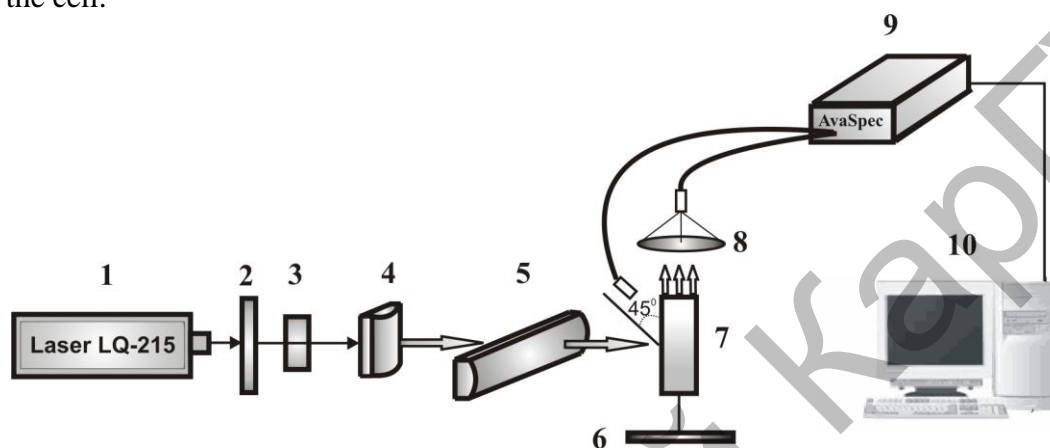

1 – laser LQ 215; 2 – neutral density filters; 3 – aperture; 4,5 – cylindrical lens; 6 – nontransmitting mirror; 7 – the sample; 8 – converging lens; 9 – AvaSpec-2048 spectrometer; 10 – computer

Fig.1. Scheme of apparatus for the study of the lasing characteristics of molecular systems

Pump power density was varied with the help of neutral density filter (2) and was $0.005\text{-}0.2 \text{ MW/cm}^2$. Stimulated emission with the help of converging lens (7) focused on the input of optical fiber spectrometer AvaSpec-2048. The lasing spectra were measured on spectrometer AvaSpec-2048 (8) connected to the computer (9). Relative error in the determination of the spectral characteristics was 3%.

The research was carried out superradiance R6G dye by measuring the luminescence of solutions for "reflection". In this case, the receiver part of the fiber located was assumed at an angle 45° to the front wall of the cell (Fig. 1).

Results and Discussion

Absorption spectrum of silver nanoparticles (fig. 2, curve 1) exhibits as a broad band with the maximum at 428 nm and have a strong overlapping with absorption and fluorescence spectra of Rhodamine 6G (fig.2, curves 2, 3). It is evidence that conditions of plasmonic resonance are stratified. Absorbance in the maximum of the absorption band increased from 0.03 to 2.2 upon growth of the concentration of silver nanoparticles in the range of $10^{-6} - 10^{-3} \text{ mol/l}$.

Absorption band of dye at a concentration of 10^{-5} mol/l has a maximum at a wavelength $\lambda_{\text{max}} = 531 \text{ nm}$ and half-width $\Delta\lambda_{1/2}^{\text{abs}} = 32 \text{ nm}$ in pure aqueous solution. Increasing of concentration of the dye leads to the broadening of absorption band due to the development of the aggregation process. Slight decrease in absorptivity ability of the dye solution was registered upon addition of silver nanoparticles to the dye solution. Optical density in the absorption band of Rhodamine 6G decreases in 1.2 times when silver nanoparticles with concentration of 10^{-3} mol/l were added to a colored solution. The position of the peak in the absorption band and its half-width does not change. Decrease of absorbance of Rhodamine 6G in the presence of Ag nanoparticles was also observed in the work [15].

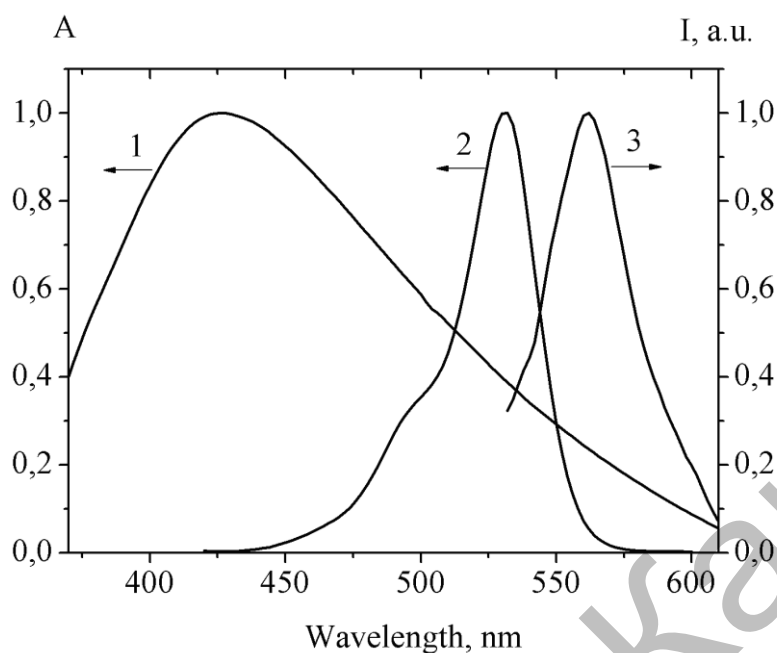

Fig.2. Relative arrangement of the spectra of absorption of Ag nanoparticles (1), Rhodamine 6G (2) and fluorescence of dye (3) in aqueous-ethanol solution

Absorption band of dye at a concentration of 10^{-5} mol/l has a maximum at a wavelength $\lambda_{\max} = 531$ nm and half-width $\Delta\lambda_{1/2}^{abs} = 32$ nm in pure aqueous solution. Increasing of concentration of the dye leads to the broadening of absorption band due to the development of the aggregation process. Slight decrease in absorptivity ability of the dye solution was registered upon addition of silver nanoparticles to the dye solution. Optical density in the absorption band of Rhodamine 6G decreases in 1.2 times when silver nanoparticles with concentration of 10^{-3} mol/l were added to a colored solution. The position of the peak in the absorption band and its half-width does not change. Decrease of absorbance of Rhodamine 6G in the presence of Ag nanoparticles was also observed in the work [15].

Upon photoexcitation of aqueous solution of rhodamine 6G with concentration of 10^{-5} mol/l a spontaneous fluorescence of dye with the maxima of spectrum at 564 nm and band-width of 34 nm was observed. When added to the aqueous solution of silver nanoparticles R6G fluorescence intensity depends on the concentration of dye nano particulars Ag (see Table 1).

Intensity of dye fluorescence increases with increasing of Ag nanoparticles up to $C_{Ag} = 10^{-4}$ mol/l. Further growth in the C_{Ag} results in quenching of fluorescence. Position of the maximum of band and its half-width does not change.

Measurements of the kinetic characteristics of the fluorescence in time-correlated photon counting mode under excitation of samples by a diode laser ($\lambda_{\text{gen}} = 488$ nm, $\tau = 150$ ps), showed that the decay of fluorescence of Rhodamine 6G occurs exponentially with $\tau_{fl} = 3.2$ ns. Life time of fluorescence of dye does not change in the presence of silver nanoparticles on the solution.

According to the results of works [2,16] enhancement of fluorescence of molecules in the near field of metal nanoparticles caused due to increase the rate of excitation of fluorescence under the influence of the plasmon effect. Nonradiative energy transfer from molecules to nanoparticles occurs at arrangement of molecules near a metal surface or in contact with it. It leads to a decrease in the probability of radiative decay of the excited molecules. These reasons explains the observed dependence of the fluorescence of the dye on concentration of silver nanoparticles.

Table 1. Influence of silver NP on the fluorescence properties of R6G

$C_{Ag},$ $Mol \cdot l^{-1}$	$I_{max}^{fl},$ a.u.	$\lambda_{max}^{fl},$ nm	$\Delta\lambda_{1/2}^{fl},$ nm
0	2,43	564	34
10^{-6}	2,60	564	33
$2 \cdot 10^{-5}$	2,66	564	34
$5 \cdot 10^{-5}$	2,68	564	34
10^{-4}	2,73	564	34
$3 \cdot 10^{-4}$	2,30	564	34
$6 \cdot 10^{-4}$	2,16	564	34
10^{-3}	1,91	564	34

At low concentrations of NP Ag, when NP and dye molecules are far enough from each other, the observed increase intensity of fluorescence of due to the R6G by plasmon resonance of silver NP. At the high concentrations of Ag NP due to decrease the distance between the dye and bass dominates the nonradiative deactivation of the excited fluorescent state.

The fluorescence intensity of dye in solutions of silver NP may be increase by to the additional absorption of dye molecules dispersed silver nanoparticles of the exciting radiation. However, at high concentrations of NP is determined, apparently, is a non-radiative decay channel of the excited molecules.

To research the lasing properties were used R6G aqueous solution with a concentration of $10^{-3} Mol \cdot l^{-1}$. Figure 3 shows the emission spectra of aqueous solution of R6G at different densities of the pump power. At low densities, pump power is observed spontaneous fluorescence (curve 1) the characteristics of the spectrum, as in the steady-state excitation (Fig.2 , curve 3) . With increasing pump power band maximum intensity increases with simultaneous narrowing of the spectrum (curves 2,3). When the power density of the pump source $P = 0.05 MW/cm^2$ is observed Lasing dye with a maximum range at the 559 nm and a half-width 12.6 nm (curve 4).

When added to the dye solution of silver nanoparticles is a growth of the emission intensity and the narrowing of the band generation. Table 2 presents data on the intensity of the lasing R6G and half-width of the band at various concentrations of NP Ag. Generating maximum intensity observed at $C_{Ag} = 10^{-4} Mol \cdot l^{-1}$. At max intensity of the stimulated emission half-width of the generation decreases almost doubled. It should be noted that the maximum of the lasing spectrum is shifted to shorter wavelengths relative to the maximum of the spectrum of spontaneous fluorescence at 5 nm.

From Tables 1 and 2 show the intensity of the generation of the concentration of silver nanoparticle is correlated with data on the spontaneous fluorescence. This is evidence that the stimulated emission is born of spontaneous fluorescence.

It is known [17,18] that in a strongly scattering dispersion medium random-laser effect can be realized. In our case, this phenomenon is not observed, because otherwise, with increasing of concentration of nanoparticles, when the probability of scattering of induced emission on the nanoparticles enhanced, efficiency of random-laser should increase. The data obtained show that at high concentrations of silver nanoparticles the intensity of lasing falls.

The influence of silver nanoparticles on the lasing threshold of solutions of Rhodamine 6G was found during the experiments. Figure 5 shows the dependence of the lasing intensity on the pump power. From this curves a lasing thresholds were defined. The can be seen that lasing threshold of the laser radiation is reduced substantially (more than 10 times) in the presence of Ag nanoparticles in comparing with the pure dye solution.

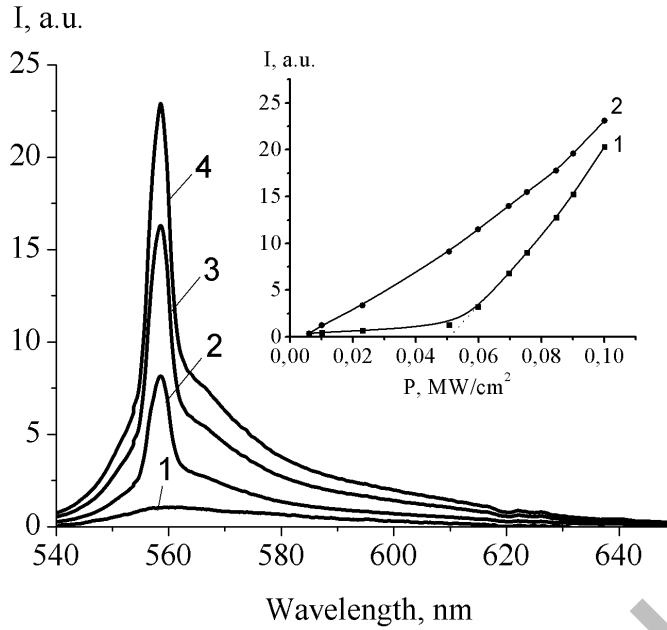

Fig.3. Emission spectra of aqueous solution of R6G at different pump power density: 1 - 0.01; 2 - 0.03; 3 - 0.04; 4 - 0.05 MW/cm². The inset shows the emission intensity on the pump energy: 1 - pure dye solution; 2 - R6G solution with $4 \cdot 10^{-4}$ mol \cdot l⁻¹ NP Ag.

Table 2. Influence of Ag NP on the lasing properties of R6G in water

C_{Ag} , Mol \cdot l ⁻¹	I_{max}^{gen} , a.u.	λ_{max}^{gen} , nm	$\Delta\lambda_{1/2}$, nm
0	6,77	559	12,6
10^{-6}	6,80	559	10,8
$2 \cdot 10^{-5}$	7,06	559	9,3
$5 \cdot 10^{-5}$	7,13	559	8,4
10^{-4}	7,62	559	7,1
$3 \cdot 10^{-4}$	6,48	559	16,7
$6 \cdot 10^{-4}$	6,37	559	20,6
10^{-3}	5,32	559	21,9

When measuring the emission solutions R6G on "reflection" from the drop - maintainer excitation laser pulse is detected superluminescence that occurs due to increased spontaneous fluorescence [19,20]. View spectrum superluminescence differs from both species spontaneous fluorescence spectrum, and on the spectrum of the laser generation (Fig. 4). Maximum is shifted to shorter wavelengths compared with the fluorescence spectrum and coincides with the maximum of the lasing spectrum (Table 3). Shortwave shift of the spectrum maximum superradiance R6G in solution was observed in [10]. Spectral width is less than the half-width superradiance fluorescence spectrum, but more than that of the generation spectrum

From Table 3 it can be seen that when added to the dye solution Ag nanoparticle luminescence intensity increases until $C_{Ag} = 10^{-4}$ mol \cdot l⁻¹, and then decreases. The half-width of the spectrum increases with increasing concentration of silver nanoparticles.

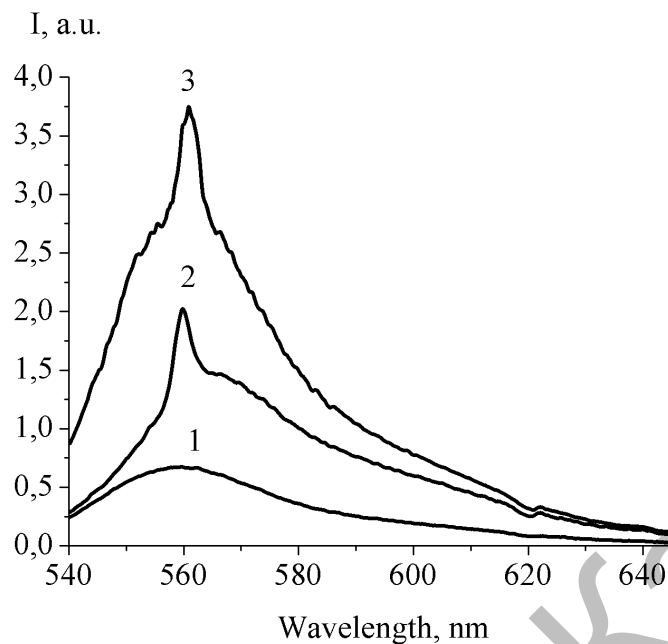

Fig. 4. Emission spectra of R6G aqueous solution measured on the "reflected" power densities at various pump: 1 - 0.05; 2 - 0,013; 3 - 0.17 MW/cm². The inset the radiation intensity on the pump energy: 1 - pure solution of the dye; 2 - R6G solution with 10⁻⁴ mol l⁻¹ NP Ag.

Table 3. Influence of Ag NP on the characteristics of superradiance R6G in water

$C_{Ag},$ Mol*l ⁻¹	$I_{max}^{superad},$ a.u.	$\lambda_{max}^{superad}$ nm	$\Delta\lambda_{1/2},$ nm
0	3,78	559	26,5
10 ⁻⁶	3,98	559	27,3
2*10 ⁻⁵	4,47	559	28,2
5*10 ⁻⁵	4,54	559	29,5
10 ⁻⁴	3,88	559	30,2
3*10 ⁻⁴	3,85	559	31,2
6*10 ⁻⁴	3,68	559	32,1
10 ⁻³	3.60	559	32,5

From the experimental data found effects on the presence of silver NP thresholds pumping superradiance (see inset Figure 4). As in the case of laser generation, the presence of Ag NP solution lowers the threshold of superluminescence. Unlike lasing for superluminescence luminescence characteristic smaller difference values lasing threshold in the absence and presence of a solution of silver NP.

Conclusion

Thus, our study showed that addition of silver nanoparticles in aqueous-ethanol solution of Rhodamine 6G leads to increasing of intensity of fluorescence of dye. Maximum of intensity of fluorescence is observed at concentrations of nanoparticles 10⁻⁴ mol/l. A further increase in the number of nanoparticles results in the quenching of fluorescence. Life time of fluorescence of Rodamine 6G was equal to 3.2 ns and does not change with the addition of silver nanoparticles in solution.

The generation of laser radiation with a maximum of spectra at 564 nm is observed upon excitation of the dye solutions with a concentration 10⁻³ mol/l by the second harmonic of Nd:YAG

laser at a power density of the pump source $P = 0,05 \text{ MW/cm}^2$. Adding of the silver nanoparticles in dye solution leads to an increase in the intensity of the emission and narrowing of lasing band. In the presence of silver nanoparticles in the dye solution decreases the lasing threshold more than 10 times.

When measuring the luminescence of solutions for "reflection" found superradiance R6G. View superradiance spectrum differs from both species spontaneous fluorescence spectrum, and on the spectrum of lasing. Maximum is shifted to shorter wavelengths compared with the fluorescence spectrum and coincides with the maximum of the lasing spectrum. Spectral width is less than the half-width superradiance fluorescence spectrum, but more than that of the generation spectrum. Unlike lasing characteristic for superradiance smaller difference values lasing threshold in the absence and presence in the solution of silver NP. Depending on the intensity of lasing and superradiance of Ag NP concentrations correlate with the data on spontaneous fluorescence. This is evidence that both types of radiation forced - born of spontaneous fluorescence.

REFERENCES

1. Klimov V.V. *Nanoplasmonics*. Moscow, Fizmatlit Publ., 2009, 480 p.
2. Maier S.A. *Plasmonics: Fundamentals and Applications*. Springer, Berlin/Heidelberg, Germany, 2007, 248 p.
3. Tian Z.Q. Surface-enhanced raman spectroscopy: advancements and applications. *Journal Ram. Spect.*, 2005, Vol. 36, No. 6–7, pp. 466 - 470.
4. Lakowicz J.R. et al. Release of the self-quenching of fluorescence near silver metallic surfaces. *Analytical Biochemistry*, 2003, Vol. 320, No. 1, pp. 13–20.
5. German A.E., Gachko G.A. Dependence of the GRS and the fluorescence on the distance between the adsorbed molecule and the metal surface. *J. Appl. Spectr.*, 2001, No. 6, pp. 757–760.
6. Homola J., Yee S. S., Gauglitz G. Surface plasmon resonance sensors: review. *Sens Actuators B Chem.*, 1999, No. 54 (1-2), pp. 3–15.
7. Novotny L., Hecht B. *Principles of nano-optics*. Cambridge, Cambridge University Press, 2006, 539 p.
8. Oulton R.F. et al. Plasmon lasers at deep subwavelength scale. *Nature*, 2009, No. 461, pp. 629 – 632.
9. Vedraïne S., Gernigon V., Torchio Ph., Flory F., Heiser T., Leveque P., Escoubas L. Surface plasmon effect on metallic nanoparticles integrated in organic solar cells. *Proc. SPIE.*, 2011, Vol. 8172, pp. 81720G1 – 81720G7.
10. Donchenko V.A., Zemlyanov A.I.A., Panamarev N.S., Kharenkov V.A. *Optical characteristics of nano-dispersed active media*. Tomsk, NTL Publ., 2012, 128 p.
11. Donchenko V.A., Edreev I.A., Zemlyanov A.I.A., Kharenkov V.A. Features the superluminescence in solutions R6G agglomerated metal nanoparticles. *Russian Physics Journal*, 2013, Vol. 56, No. 8, pp. 9 – 15.
12. Vasa P, Pomraenke R, Schwieger S, Mazur YI, Kunets V, Srinivasan P, Johnson E, Kihm J, Kim D, Runge E. Coherent exciton-surface-plasmonpolariton interaction in hybrid metal-semiconductor nanostructures. *Phys Rev Lett.*, 2008, pp. 101:116801.
13. Kim W., Safonov V. P., Shalaev V. M., and Armstrong R. L. Fractals in microcavities: giant coupled, multiplicative enhancement of optical responses. *Phys. Rev. Lett.*, 1999, Vol. 82, No. 24, pp. 4811–4814.
14. Sheng, R.S., Zhu L., Morris M.D. Sedimentation classification of silver colloids for SERS. *Analytical Chemistry*, 1986, No. 58(6), pp. 1116.
15. Santhi A., Umadevi M., Ramakrishnan V., Radhakrishnan P., Nampoore V.P.N. Effect of silver nano particles on the fluorescence quantum yield of Rhodamine 6G determined using dual beam thermal lens method. *Spectrochimica Acta. Part A*, 2004, No. 60, pp. 1077–1083.
16. Anger P., Bharadwaj P., Novotny L. Enhancement and quenching of single-molecule fluorescence. *Phys. Rev. Lett.*, 2006, PRL 96, pp. 113002.
17. Cao H. Waves Random Media . *Topical Rev.*, 2003, Vol. 13, pp. R1–R 39.
18. Wiersma D.S. The physics and applications of random lasers. *Nature Phys.*, 2008, Vol. 4, pp. 359–367.
19. Zvelto O. *Principles of lasers*. Moscow, Mir Publ., 1990, 560 p.
20. Kopylov S.M., Lysoi B.G., Seregin S.L., Cherednychenko O.B. *Tunable dye lasers and their applications*. Moscow, Radio and communications Publ, 1991, 240 p.