

UDC 533.682

**MODELING OF DISPERSION PROCESS OF WATER COAL FUEL RECEIVED FROM SLIMES OF THE SHUBARKUL COAL**

Kussaiynov K.K.<sup>1</sup>, Satybaldin A.Zh.<sup>1</sup>, Tanasheva N.K.<sup>1</sup>,  
Sadenova K.K.<sup>1</sup>, Rustamova L.K.<sup>1</sup>, Karagaeva M.B.<sup>2</sup>

<sup>1</sup>E.A. Buketov Karaganda state university, Universitetskaya Str.28, Karaganda, 100026, Kazakhstan,  
[nazgulya\\_tans@mail.ru](mailto:nazgulya_tans@mail.ru)

<sup>2</sup>Karaganda Economic University, Akademicheskaya Str. 9, Karaganda, 100009, Kazakhstan

*The article is devoted to features of burning of water coal fuel of the Shubarkul coal received by electrohydropulse processing from slimes. Computer modeling of dispersion process when burning water coal fuel by means of software package of ANSYS FLUENT was made. The model of geometrical area of installation is received. The picture of a field of temperatures is given in the nozzle plane. The schedule of change of temperature of a coal particle and drop of WCF from various parameters is shown.*

**Keywords:** water coal fuel, ANSYS FLUENT, coal, computer modeling.

Hydrocarbon fuel (WCF) is one of the most effective substitutes of coal, expensive liquid fuels and natural gas. Application of WCF is effective since it creates ecological purity, high culture in a boiler room and provides profitability by burning combustible [1].

Now there is a reconsideration of role and importance of coal in providing energy and economic security of the state. Thus, the increase of coal share in fuel balance is a stabilizing factor of protection of deep energy crises. However, environmental problems arising within the use of coal, demand development and implementation of new environmentally pure coal technologies. In this regard the use of coal in the form of suspension coal fuel is perspective (WCF). Implementation of WCF provides savings of energy and material resources and environment as well. In addition, the use of WCF is the most effective and environmentally pure method of utilization of thin coal slimes of mining- and recycling coal enterprises.

For use of water coal fuel (WCF) in an energy except WCF preparation, effective ways of its burning are obviously necessary also.

The very process of burning water coal fuel is not only a technical but a research interest as well. The feature of coal burning as a part of WCF is that burning happens in WCF drop, wherein, unlike coal dust burning, at burning of WCF there are at least two mechanisms:

- Classical burning on "drying-ignition-burning mechanism";
- Decomposition of "coal + water" ( $C + H_2O$ ) on synthesis gas ( $CO + H_2$ ).

Today more than ten types of steam and hot water boilers on which WCF burning (DKVR, DE, KE, BKZ and others) is made are approved. In most cases a torch or vortex burning is used. Depending on brands of boilers and a specific situation at place, WCF burning is possible by replacement of nozzles on wearproof while working with WCF in standard oil-gas burners. In certain cases the change of aerodynamics of fuel burning that allows to use still not only WCF but also gas and/or fuel oil is required transferring them to the category of reserve fuel. Produced reconstructions allow burning WCF completely independently without flame stabilization by fuel oil or gas. However, in some cases it is more advisable to consider not only complete replacement of gas/fuel oil with WCF but partial as well. Preservation of 10 - 15% of fuel oil in fuel balance of a boiler can simplify its reconstruction that will allow reducing capital costs on transfer to WCF.

So far the technology of producing and use of WCF reached level of industrial application. However, a large amount of water, existence of mineral components in particles in size of 40-80

microns and rather low warmth of burning, that is, 12-17 MJ/kg demand certain conditions for reliable ignition, sustainable and efficient burning of WCF in fire chambers.

Suspension water coal fuel is a disperse system consisting of micronized coal of Shubarkul deposit (coal slime), water and reagent-softener.

The vortex way of burning [2] provides maximum burning of coal particles using mechanisms of internal stabilization of burning that are characteristic for vortex fire chambers. Stabilization of burning in vortex fire chambers is provided because hot burning products are directed to the root of this torch and it provides reliable ignition at relatively low temperature. Besides, due to tangential input of blasting streams the vortex current and hashing of hot products combustion with coming streams that provides the highest burnup of fuel and combustion stability is organized.

The burning process of the sprayed drops of water coal fuel represents a combination of burning of two model systems: coal particles with the diameter  $d > 80$ -100 microns and water coal drops with the diameter  $d > 80$ -100 microns. For the description of gas flow and the weighed particles the method combining the Euler and Lagrangian approaches is used. For today this method is developing actively including for two-phase streams with high concentration of disperse phase as it allows to consider polydispersion of particles and in details to observe the behavior of the weighed reacting particles [2-3].

According to this method the general equations of the movement, heat exchange and burning in a gas phase are represented on the basis of the Euler way of the description, i.e. the stationary spatial equations of balance of weight, concentration of gas components and energy for gas mix and impulse are used.

Together with the Russian scientists theoretical calculations by means of a software package of ANSYS FLUENT allowing to model process of burning of the water coal fuel received by electrohydropulse processing from slimes of the Shubarkul coals taking into account turbulence, heat exchange and chemical reactions were carried out. For design of the settlement grid in the field of the camera the GAMBIT package that is geometrical and net preprocessor for FLUENT was used. Turbulent viscosity is calculated with the help of two-parametrical «k-ε» model. Thermophysical properties of air are calculated in accordance with polynomial dependence on temperature. Parameters of injection of drops of water coal fuel in the camera are set by means of the Discrete Phase Model.

In figure 1 the geometry of the modelled area is shown.

For dispersion of the water coal fuel received by electrohydropulse processing from slimes of the Shubarkul coals compressed air is used. For dispersion of fuel and creation of necessary conditions for ignition there is primary air heated to temperature of 300-500 °C. The amount of the air entered into the fire chamber makes 20% [4].

Boundary conditions:

On air supply through a nozzle: temperature – 300 K, opening width – 4 mm, the speed of gases – 50m/s.

On air supply through blasting channel: speed of gases – 25 m/s, temperature – 300K, turbulent energy – 0,1k.

Other numerical parameters were determined by the closest cells.

For theoretical calculation of the movement of particles of coal and the drops of water coal fuel the model of discrete phase based on the Lagrangian formulation of interaction of discrete and continuous phase was used [5,6].

The calculations performed in the software package "FLUENT" allow to receive distribution of speed and temperature in various sections of the fire chamber, and also trajectory of the movement of particles of fuel in a vortex fire chamber.

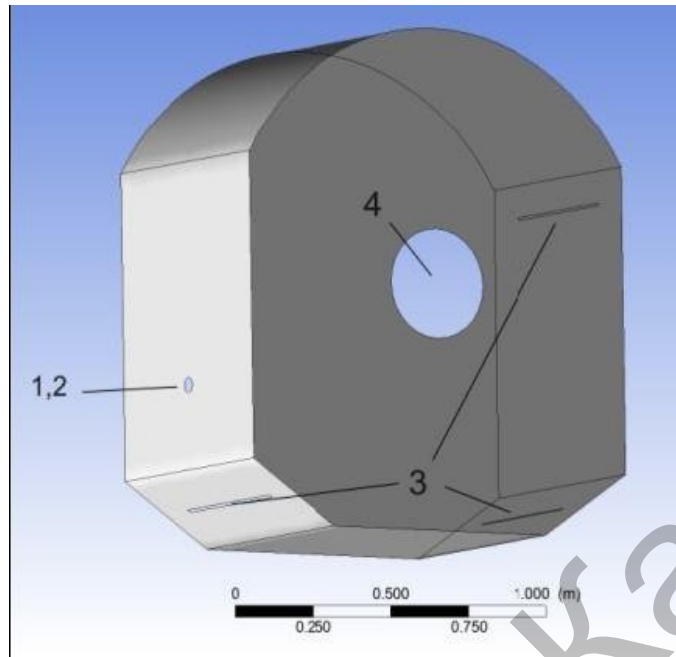

1 – copper camera, 2 - nozzle, 3 - systems of blasting, 4-exhaust outlet

Fig.1.Model of geometrical area

In figures 2, 3 the field of temperatures of evaporation mass speed of liquid phase in WCF drop is shown.

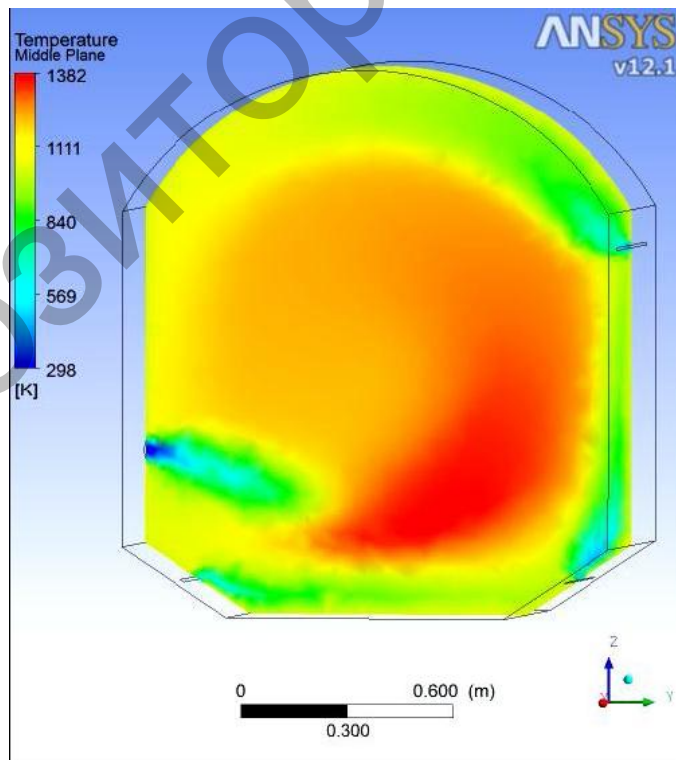

Fig.2.Field of temperatures in the nozzle plane

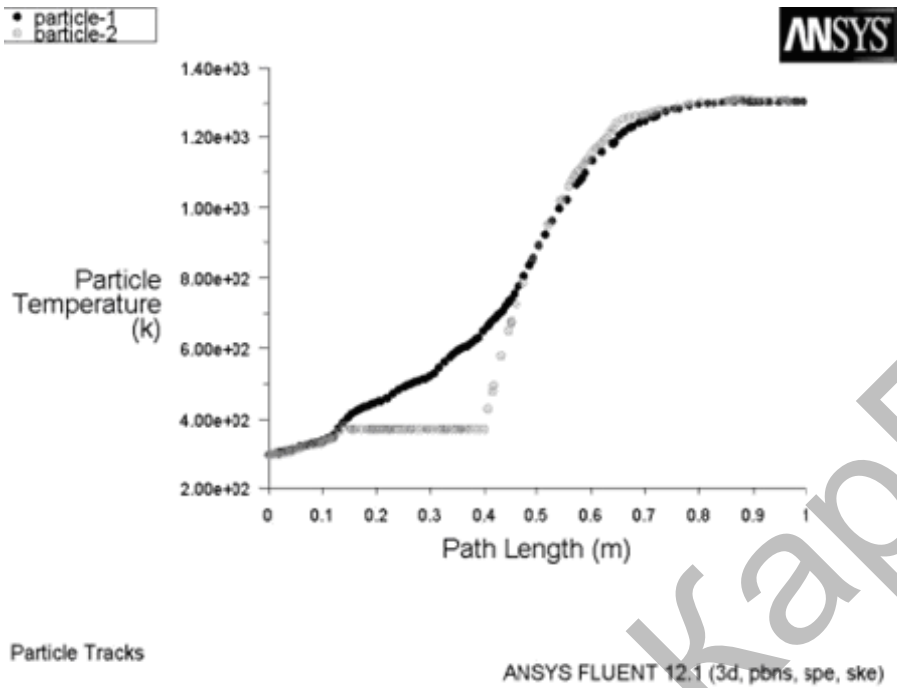

Fig.3. Changes of temperature of coal particle (particle 1) and a drop of WCF (particle 2) depending on length of the way of a particle and drop

The graphic dependences presented in figure 3 show that unlike monotonous increase in temperature of a coal particle (particle 1) while its movement temperature of a drop of water coal fuel (particle 2), after increase up to the temperature of evaporation of liquid phase, remains invariable for all process of evaporation.

Further, there are processes of burning of hard phase of a drop of water coal fuel to heat release, the instant increase in temperature is also observed.

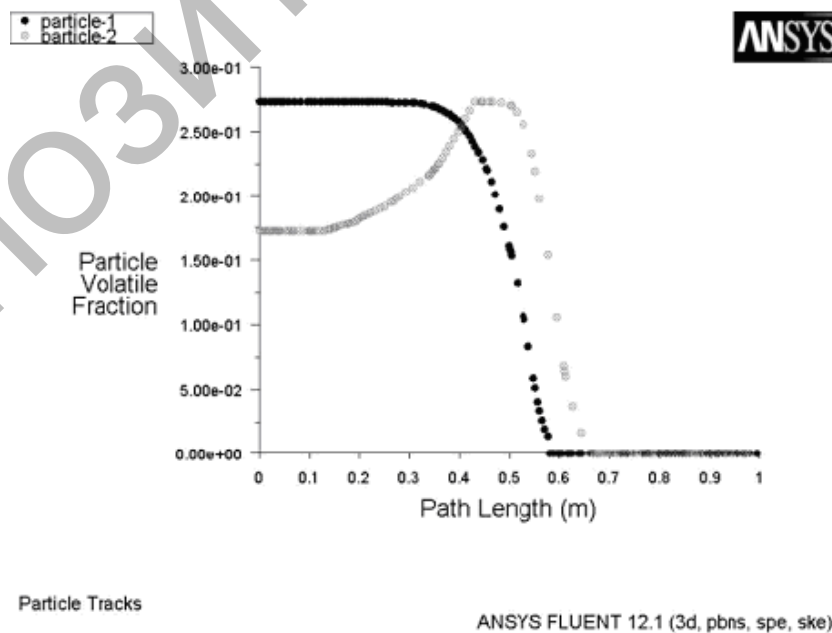

Fig.4. Changes of the content of volatiles in a coal particle (particle 1) and a drop of WCF (particle 2) depending on length of the way of a particle and a drop

In figure 4 it is shown that the content of volatiles for a coal particle (particle 1) at the beginning of process remains constant and decreases only when heating a particle to temperature of release of volatiles. For the drops of water coal fuel received by electrohydropulse processing from slimes of the Shubarkul coals (particle 2) increase the amount of volatiles due to water evaporation is observed. Then, in the course of evaporation, temperature of the hard phase of a drop of water coal fuel increases, and the number of volatiles reaches the value for a hard coal particle.

During much long period stability of process of evaporation remains due to temperature increase of a hard phase of a drop of water coal fuel.

Therefore, computer modeling of process of burning of fuel allows to define the optimum modes of process of burning and burning of the water coal fuel received by electrohydropulse processing from slimes of the Shubarkul coals. The obtained data can be also useful when developing constructions of the burning devices with the increased efficiency.

## REFERENCES

1. Sunggyu Lee, James G. Speight, Sudarshan K. Loyalka. *Handbook of alternative fuel technologies*. CKC Press, 2007, pp.48–56.
2. Murko V.I. Effect of reagent-plasticizers on the rheological properties of coal-water fuel. *Chemistry solid fuel*. 2001, No. 2, pp. 62-72.
3. Murko V., Fedyaev V., Karpenok V., Dzuyba D. Application of swirl combustion technique on reduction of toxic substance in coal water mixture combustion products. *J. Clean coal technology*, 2012, No. 5, pp. 73–75
4. Kusaiynov K., Satybaldin A.Zh., Tanasheva N. K., Alpysova G. K., Tleubergenova A.Zh. The experimental stand for burning of the water coal fuel received from slimes the shubarkul coals. *The Bulletin of the Karaganda university. Physics series*, 2014, No. 3 (75), pp. 57-62.
5. Tanasheva N. K. The method of burning water coal fuel of the Shubarkul coal received from slimes. *Proceeding of the XI<sup>st</sup> Russian Conf. "Physics-chemistry and technology of inorganic materials*, Moscow, Interkontakt Nauka, 2014, pp. 477 - 479.
6. Kusaiynov K., Alpysova G.K., Tanasheva N.K. The research of burning technology of water coal fuel got from shubarkul coal. *Eurasian Physical Technical Jjournal*, 2014, No. 1 (21), pp. 7-11.