

DOI 10.31489/2019No2/94-100

UDC: 621.516.7

MATHEMATICAL MODEL OF MULTI-MOTOR PLATE CONVEYOR TRACTION BODY WITH FREQUENCY-CONTROLLED ELECTRIC DRIVE

Breido I.V.¹, Kaverin V.V.¹, Kelisbekov A.K.¹, Daniyarov N.A.², Akhmetbekova A.M.³

¹Karaganda State Technical University, APP Department, Karaganda, Kazakhstan, akelisbekov@mail.ru

²Kazakhmys Corporation LLP, Karaganda, Kazakhstan

³O.A. Baikonyrov Zhezkazgan University, Zhezkazgan, Kazakhstan

In the course of operation of chain conveyors emergency situations are possible. The reasons for this can be the intensity of the moving parts wear, increasing the pitch of the traction chains hinges, which leads to occurrence of shock loads in the traction body and failure of individual elements of the conveyor. Upon reaching a certain limiting increase in the pitch of the traction unit, further operation of the chain transmission cannot be possible due to significant decreasing the safety factor of the chains, violation of the ease of movement, or violation of the engagement of the chain joints with sprockets and cams of the intermediate drives. In the considered works dealing with studying the operating modes of plate conveyors, methods of solving the problem of distribution of loads between the master and slave drives in a multi-motor plate conveyor by means of a frequency-controlled electric drive are not considered.

Keywords: traction body, plate conveyor, frequency-controlled electric drive, load distribution, mathematical model.

Introduction

The operational experience of multi-drive plate conveyors shows that their high efficiency is possible provided that the conveyors are equipped with systems and tools for automatic distributing the total load of the conveyor between its drives, controlling the speed of the bearing belt, eliminating equalizing forces in the traction chain of the conveyor, automatic starting the multi-drive conveyor taking into account elastic-viscous properties of the traction-bearing belt and a number of other factors [1-4]. At present the intensity of developing new deposits is increasing, which leads to increasing the cargo flows. High complexity of the rock and ore delivery necessitates searching for various ways of improving the operation of open-cast plate conveyors (one of which is automation of the technological process of the conveyor operation). With the reloading-free transportation scheme, due to the presence of a two-drive system in the conveyor, it is necessary to solve the problem of automatic distribution of the total load in the traction body of the conveyor between the master and slave drives.

The distribution of load between electric drives of chain conveyors, in particular plate conveyors, was studied by such scientists as: Andrienko P.D., Babokin G.I., Bernshtein A.Ya., Blum O.O., Averbukh A.M., Borisov B.O., Brykhta P., Kachi V., Tezing X., Geiler L.B., Goykhman M.E., Hiller A.M., Saginov A.S., Daniyarov A.N., Akashev Z.T., Breido I.V., Shevchenko V.I., Yeshchin Ye.K. The analysis of works by the above scientists shows that in the course of operation of the multi-drive plate conveyor, in the traction, in addition to the calculated forces (pre-tension, static and dynamic components of resistance to movement), additional equalizing forces take place. It is clear that the reasons for their occurrence are various, but the main ones should be considered changing the conveyor loading mode, changing the values of the geometric parameters of drive parts during operation, the effect of external climatic conditions on the value of the coefficient of basic resistance to movement. In addition to the main factors, there

can be minor ones that are manifested only in certain operating modes, with a particular electric drive system. They are nonequivalence of the pitch of the traction chain links, the static error of the speed control system of the rotors of the motors of the master and slave electric drives [5-7].

In the course of operation of chain conveyors, emergency situations are possible, the causes of which can be the intensity of the moving parts wear, increasing the pitch of the traction chains hinges, which leads to the occurrence of shock loads in the traction body and failure of individual elements of the conveyor [7]. Shock loads, periodically repeated and caused by wear and extension of the traction chain lead to surge currents in the power part of the electric drive power supply, which subsequently leads to overheating of the electric motor. Upon reaching a certain limiting increase in the pitch of the traction unit, further operation of the chain transmission cannot be possible due to a significant decrease in the safety factor of the chains, violation of the ease of movement or disturbance of engagement of the chain joints with sprockets and cams of the intermediate drives, which leads to frequent failures in the course of operation of the conveyor traction body [8]. The progress achieved in the development of power semiconductor technology, the creation of high-quality and powerful frequency converters using PWM modulation, the introduction of high-speed and high-discharge industrial controllers made it possible to use frequency-controlled AC drives for plate conveyors based on commercially available asynchronous motors for the mining industry [9-15].

It should be noted that in the presented works dealing with studying and modernizing plate conveyor operating modes, methods of solving the problem of load distribution between the master and slave drives in a multi-motor plate conveyor by means of a frequency-controlled electric drive are not considered. Based on the foregoing, it is relevant to solve the problem of load distribution between the master and slave drives. The objective of this work is to develop mathematical models that describe dynamic processes of the traction body and methods of load distribution between the master and slave electric drives of a multi-motor plate conveyor by means of a frequency-controlled electric drive, taking into account elastic properties of the traction body of the plate conveyor. The moments of the master and slave frequency-controlled electric drives are taken as the input parameters of the model.

Objective of the work: developing mathematical models describing the dynamic processes of the traction body operation and methods of load distribution between the master and slave electric drives of a multi-motor plate conveyor by means of a frequency-controlled electric drive, taking into account elastic properties of the traction body.

1. Analysis of previously developed methods of solving the problem

In work [1] it was noted that the most acceptable method of control providing the reduction of equalizing forces in the traction chain to minimum values is a combined one. The mismatch of the rotation angles of the shafts of the drive chain sprockets is controlled, and at the same time, the elastic elongations of the traction body on each span are compensated by working out the force difference between the actual tension value at the end point of the inter-drive section and its value corresponding to this load mode. The disadvantage of this method is that it is difficult to achieve the accuracy of matching the rotation angles of the drive sprockets due to the difference in the calculated geometric parameters of the structures of the electric drive and traction body parts and components and the actual ones.

In the work by Dr. Engineering, Professor I.V. Breido there was studied the automatic load distribution system in the course of industrial tests of the SPM-128P face conveyor with a thyristor electric drive, by stabilizing the speed on the master drive and the load moment on the slave drive [2]. During the test, the ratio between the load current of the master drive and the load current of the slave drive was 2:1. In this method there were used adjustable DC electric drives with sequential excitation motors, which do not allow providing the required dynamic characteristics to compensate for the elastic elongations of the traction body of the plate conveyor.

In the article by G. Babokin it was proposed to perform load balancing between the head and end electric drives of the conveyor by separate control of frequency converters supplying asynchronous motors (AM) of the head and end drives [8]. When considering the electric drive, the law of frequency control was adopted with maintaining a constant flow of the AM; active resistance of the AM stator was not taken into account in this version, and the load of the AM within the working area of mechanical characteristics was considered. Under the difference between the parameters of the head and end drives, their mechanical characteristics come from one point on the frequency axis and have different slopes to the moment axis. The load distribution between the drives is proportional to the rigidity of the mechanical characteristics. To equalize the loads of the head and end drives, it is proposed to control simultaneously the rotational speeds of both drives (AM): for the mechanical characteristic having a higher rigidity, down from the rated one, and for the one with a lower rigidity, up from the rated one until the AM moments are equal (1:1). The use of the variable frequency drive allows damping dynamic loads in a higher frequency region, which is typical for plate conveyors. The disadvantage of this method is the equal predetermined ratio of traction moments of the master and slave drives, which does not take into account the different loads acting on the working and idle branches of the traction body.

Thus, to ensure constant conveyor performance with variable load per unit of length of the traction body, as well as to distribute loads between the master and slave drives, it is necessary to equip plate conveyors with frequency-controlled electric drives. Among the commercially available electric motors in the CIS countries with an independent cooling system that provides high torque characteristics in a wide speed range, there are known the FCAMs series [16].

2. Results of mathematical modeling of the traction body of the plate conveyor

Having reached the rated speed of movement of traction body (1), the conveyor begins to be loaded with ore from hopper (2) (Fig. 1). When the traction body is fully loaded with the load (3) of mass m , head master electric drive (4) starts working to move the loaded upper branch (6) of the traction body, end slave electric drive (5) of the lower branch (7), respectively.

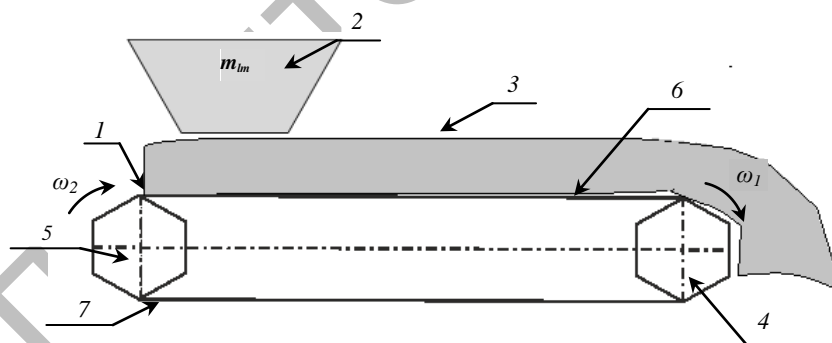

Fig.1. Diagram of loading a multi-motor plate conveyor with ore

The elements of the traction body of the multi-drive conveyor (MDC) possess elasticity, rigidity, inertia the values of which must be taken into account when developing a mathematical model that describes the dynamic processes that occur in various units of the MDC in the course of its operation. To solve the problems of dynamics, the studied MDC units can be represented in the form of separate inertial elements interconnected by elastic bonds. For transient processes (starting, braking, speed change) it is necessary to take into account the effect of rotating and linearly moving parts of the traction body, electric drive, and the load mass. To do this, there is used the method of bringing all the moving masses to the shafts of the corresponding motors. The calculation formulas are compiled for the complete bringing to the motor shafts the moments of inertia of the rotating parts of the gearboxes, the moving traction body, and the load mass. The masses of the upper branch of the traction-carrying body, sprockets and rotating parts of the first gearbox are brought to

the rotor of the driving motor, the masses of the lower branches of the traction body, sprockets and rotating parts of the second gearbox are brought to the rotor of the driven slave motor. Thus, the conveyor is replaced by a two-mass system connected by elastic links of the lower and upper branches. The diagram of a multi-motor plate conveyor with asynchronous frequency-controlled electric drives is presented in Figure 2.

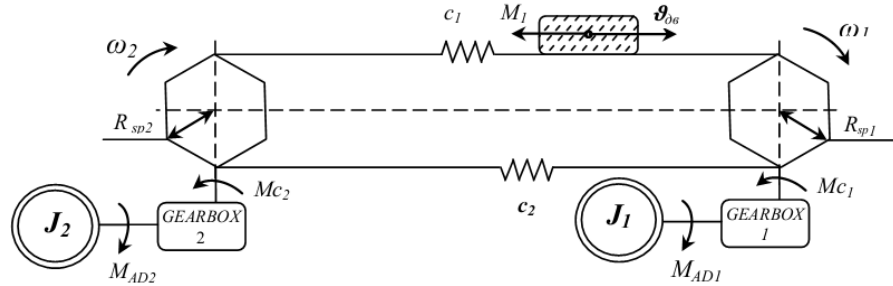

Fig.2. The diagram of a multi-motor plate conveyor with asynchronous frequency-controlled electric drives

The system of equations for the conveyor and the conditions under which the load is distributed between the electric drives (limiting unreasonable dynamic overloads in the traction body of the plate conveyor) is presented below:

$$J_{\Sigma 1} \frac{d\omega_1}{dt} = M_{AD1} - M_{c1} - M_{lm} - c_1 \int (\omega_1 - \omega_2) dt + c_2 \int (\omega_2 - \omega_1) dt \quad (1)$$

$$J_{\Sigma 2} \frac{d\omega_2}{dt} = M_{AD2} - M_{c2} - c_2 \int (\omega_2 - \omega_1) dt + c_1 \int (\omega_1 - \omega_2) dt \quad (2)$$

$$J_{\Sigma 1} = (J'_{red1} + J'_{red2}) \frac{1}{i_1^2 \eta_{r1}} + J_{AD1} = (m_{ub} + m_{lm}) \frac{R_1^2}{2i_1^2 \eta_{r1}} + J_{AD1} \quad (3)$$

$$J_{\Sigma 2} = J''_{red1} \frac{1}{i_2^2 \eta_{r2}} + J_{AD2} = m_{lb} \frac{R_2^2}{2i_2^2 \eta_{r2}} + J_{AD2} \quad (4)$$

$$c = dP / d\varepsilon, \quad \text{at} \quad [P_{min} \langle P_{nom} \langle P_{max}] \quad (5)$$

$$M_i = 2M_{ki} S_{kn} (S_n / (S_n^2 + S_{kn}^2)), \quad \text{at} \quad [M_{min} \langle M_{nom} \langle M_{max}] \quad (6)$$

where:

M_{AD1} is the electromagnetic moment developed by the first master electric motor;

M_{c1} is the static moment reduced to the shaft of the first electric motor;

M_{AD2} is the electromagnetic moment developed by the second slave electric motor;

M_{c2} is the static moment reduced to the shaft of the second motor;

M_{lm} is the moment of resistance forces from the mass of the load transported;

ω_1, ω_2 are the angle speeds of rotation of the first and second electric motors, respectively;

$J_{\Sigma 1}$ is the inertia moment of the upper branch of the traction body taking into account the mass of the load transported reduced to the master electric motor;

$J_{\Sigma 2}$ is the inertia moment of the lower branch of the traction body taking into account the mass of the load transported reduced to the slave electric motor;

c_1, c_2 are the coefficients of rigidity of the upper and lower branches, respectively;

J'_{red1} are the reduced inertia moments of the traction body upper branch;

J'_{red2} are the reduced moments of the transported load mass inertia;

J''_{red1} are the reduced moments of the traction body lower branch mass inertia;

m_{ub}, m_{lm} are the masses of the upper branch and the load reduced to the radius of sprocket of the master drive;

m_{lm} is the mass of the lower branch reduced to the radius of sprocket of the slave drive;

i_1, i_2 are the transfer ratios from the master and slave motors shafts to the corresponding gearboxes;

P is the conveyor traction body tension;

R_{sp1}, R_{sp2} are the radiuses of the master and slave drives sprockets;

M_i is the torque developed by the n -th drive;

M_{ki} is the critical moment developed by the n -th drive;

ε_i is the relative deformation of the traction body on the i -th drive.

This system of equations simulates the operation of a plate conveyor that is represented by a two-mass system with various inertial masses and moments of resistance. The inertia of the master drive is determined by the transported inertial masses of the master drive, the traction body, taking into account the parameters of the gearbox, as well as the flywheel masses of the asynchronous motor. The inertia of the slave drive is determined by the masses of the lower branch, the characteristics of the gearbox and the flywheel masses of the motor. The calculated resistance values of the master and slave drives must be determined taking into account the effect of external climatic conditions of operation.

It is known that the traction body rigidity directly depends on traction tension. From the first condition $c = dP/d\varepsilon$ for ensuring the limitation of traction efforts it follows that rigidity (the elastic modulus) of the upper branch of the traction body changes in the course of the conveyor operation depending on the degree of loading the working branch. In the mathematical model for describing the operation of the conveyor, the presented parameters: $M_{c1}, M_{lm}, M_{c2}, c_1 \int (\omega_1 - \omega_2) dt, c_2 \int (\omega_2 - \omega_1) dt$ are variable. So with the passage of time, they change depending on the characteristics of individual operating modes, the effect of external technological operating conditions and other factors.

In the course of the conveyor operation, increasing the critical slip of the induction motor and rigidity (the elastic modulus) of the traction body leads to a more uniform load distribution between the drives. The electromagnetic moment of the induction motor is developed by the interaction of the current in the rotor winding with the rotating magnetic field of the stator. The electromagnetic moment is inversely proportional to the frequency of the current supply network:

$$M_{AD} = N / \omega = (N \times p) / (2\pi f) \quad (7)$$

The moment of resistance forces from the mass of the transported load acting on the upper branch of the traction body is determined by the following expression:

$$M_{lm} = cg / (q_{tb} + q_n), \quad (8)$$

where:

c is rigidity (elasticity) of the traction body;

g is acceleration of gravity;

q_{tb} is the linear mass of the traction body;

q_n is the mass per unit of length on the traction body.

In order to develop a simulation model of the traction body of a multi-motor plate conveyor with a frequency-controlled electric drive, it is necessary to bring differential equations (1-6) into relative units. After the corresponding transformations, there is obtained the system of equations of the conveyor transfer function:

$$T_1 \frac{d\omega_1^*}{dt} = (M_{AD1}^* - M_{c1}^* - M_{lm}^*) - \frac{1}{T_1} \int (\omega_1^* - \omega_2^*) dt + \frac{1}{T_3} \int (\omega_2^* - \omega_1^*) dt \quad (9)$$

$$T_4 \frac{d\omega_2^*}{dt} = (M_{AD2}^* - M_{c2}^*) - \frac{1}{T_3} \int (\omega_2^* - \omega_1^*) dt + \frac{1}{T_2} \int (\omega_1^* - \omega_2^*) dt \quad (10)$$

where:

$$T_1 = \frac{\omega_{n1}}{M_{n1}} J_{\Sigma 1} \text{ is the time constant of the first master electric drive;}$$

$$T_2 = \frac{M_{n1}}{\omega_{n1} c_1} \text{ is the time constant of the moment of elastic oscillations of the upper branch;}$$

$$T_3 = \frac{M_{n2}}{\omega_{n2} c_2} \text{ is the time constant of elastic oscillations of the lower branch;}$$

$$T_4 = \frac{\omega_{n2}}{M_{n2}} J_{\Sigma 2} \text{ is the time constant of the second slave electric drive.}$$

$$T_1 = \frac{\omega_{n1}}{M_{n1}} J_{\Sigma 1} = 2.15s, T_2 = \frac{M_{n1}}{\omega_{n1} c_1} = 0.17s, T_3 = \frac{M_{n2}}{\omega_{n2} c_2} = 0.09s, T_4 = \frac{\omega_{n2}}{M_{n2}} J_{\Sigma 2} = 1.43s$$

Table 1. Specifications and time constants of the conveyor electric drives and traction body

Type of asynchronous motor	Names of parameters								
	Rated power, kW	Rated/max. speed, rpm	Rated moment, Nm	Rated current, A	Rated voltage, V	Rated frequency, Hz	Rotor J, kg/m ²	Cos φ	T ₁ and T ₄ , respect.
Head master FCAM280S4	110	1450/4500	707	202	380	50	2.2	0.85	2.15
End slave FCAM225M4	55	1450/4500	356	105	380	50	0.5	0.86	1.43

Conclusion

In this work there is substantiated the relevance of theoretical studies of plate conveyors with the master and slave adjustable drives. An equivalent circuit for the traction body has been developed and justified taking into account the flywheel masses of the electric motor and the gear ratio of the gearbox.

The article presents the developed mathematical model in relative units that describes dynamic processes of the traction body of the plate conveyor. Based on this model, the transfer function has been constructed and the time constants of the dynamic moments and moments of elastic vibrational forces of the working and idle branches of the traction body have been calculated. The developed model can be used to synthesize a load distribution system in a frequency-controlled electric drive of a plate conveyor.

Based on the above-said, there has been proposed a method for ensuring load distribution between the master and slave adjustable drives of the plate conveyor, taking into account characteristics of its technical parameters and technological operating conditions.

REFERENCES

- 1 Saginov A.S., Daniyarov A.N., Akashev Z.T. *Fundamentals of design and calculation of career plate conveyors*. Alma-Ata, Nauka, 1984, 28 p. [in Russian]
- 2 Breido I.V. *Control principles and methods for the synthesis of controlled electric drives of underground mining machines*. Almaty, Giga Trade, 2012, pp. 78-85. [in Russian]
- 3 Breido I.V., Daniyarov N.A., Kelisbekov A.K., Akhmetbekova A.M. Using Soft Start Method in Multi-Drive Plate Conveyor Operation. *University Proceedings Journal*, KSTU Publ. House, 2018, No.4, pp.124. [in Russian]
- 4 Breido I.V., Intykov T.S., Daniyarov N.A., Kelisbekov A.K., Semykina I.Yu. Mathematical model of apron conveyor controlled Electric drive in operation starting modes. *NEWS of the Academy of Sciences of the Republic of Kazakhstan*, 2019, Vol. 2, No. 434, pp. 232-237. doi.org/10.32014/2019.2518-170X.59.
- 5 Belenky D.M., Kuznetsov D.G. *Plate conveyors*. Moscow, Nedra Publishing House, 1971, 184 p. [in Russian]
- 6 Perten Yu.A., Volkov R.A., Gnutov A.N., Dyachkov V.K. *Conveyors*. Reference book. Leningrad Motorering, 1984, 76 p. [in Russian]
- 7 Tazabekov I.I., Daniyarov N.A., Balgabekov T.K. *Adjustable drives of main chain conveyors*. Monograph. Karaganda, Publishing house of KSTU, 2009, 163 p. [in Russian]
- 8 Babokin G.I. Twin motor electric conveyor with load balancing system. *Izvestiya TulGU. Technical science*, 2010, Issue 3, Part 2, pp. 7. [in Russian]
- 9 Pajchrowski, T. Comparison of control structures for direct drive with PMSM motor with variable inertia and load torque. *Przegląd Elektrotechniczny*. 2018, Vol. 94, No.5, pp. 133-138.
- 10 Breido I.V., Sivyakova G., & Gurushkin A. State and Prospects of Developing the Interconnected Multi-motor Semiconductor Electric Drives. *Industrial Motorering—Challenges for the Future*. 2013, pp. 311 – 330.
- 11 Breido I.V. The State and Prospects of Development of the Interconnected Multi-Motor Semiconductor Electric Drives. *Scientific Book*. 2013, Vol. 12, pp. 193-212.
- 12 Breido I., Kaverin V., Ivanov V. Telemetric Monitoring Insulation Condition of High Voltage Overhead Power Lines. *Proceedings of the 29th DAAAM International Symposium*. 2018. pp.0319-0328. doi:10.2507/29th.daaam.proceedings.046.
- 13 Štatkić S., Jeftenić I.B., Bebić M.Z., et al. Reliability assessment of the single motor drive of the belt conveyor on Drmno open-pit mine. *International Journal of Electrical Power and Energy Systems*, 2019, Vol. 113, pp. 393-402. doi: 10.1016/j.ijepes.2019.05.062
- 14 Windmann S., Niggemann O., Stichweh, H. Computation of energy efficient driving speeds in conveying systems. *At-Automatisierungstechnik*. 2018, Vol. 66 (4), pp. 308-319. doi: [10.1515/auto-2017-0094](https://doi.org/10.1515/auto-2017-0094)
- 15 Świder, J., Herbuś, K., Szewerda, K. Control of Selected Operational Parameters of the Scraper Conveyor to Improve Its Working Conditions. *Advances in Intelligent Systems and Computing*, 2019, 2019934, pp. 395 – 405. doi: [10.1007/978-3-030-15857-6_39](https://doi.org/10.1007/978-3-030-15857-6_39)
- 16 The catalog of FCAM. Research and Development Design and Technological Institute of Electrical Motorering of Russia. 2014, pp. 31 – 34. http://www.ruselprom.ru/upload/iblock/912/katalog_2014.pdf