

UDC 53:004

**ANALYSIS OF ELECTRICAL FILTERS IN HIGH LEVEL LANGUAGE C ++**

Amochaeva G.P., Zakiev D.M.

Karaganda state University named after E.A. Buketov, Universitetskaia St. 28, Karaganda, 100026, Kazakhstan,  
galina\_amochoeva@mail.ru

*Article presents a synthesis system of active electric filters on the basis of its mathematical models provided by linear transfer functions. Each filter is implemented to operational amplifiers, resistors and capacitors. All filter elements are linear, concentrated and invariant over time. The initial data for the synthesis filters are the cut-off frequency response model of dynamic links and angles of inclination to the axis (dB / decade). Initial data for calculation of filters are the nominal values of capacitors stored in the corresponding file. The developed system has the ability to expand at the expense of updating files that contain the concepts of unit cells of active filters and nominal values of capacitors.*

**Keywords:** Workbench, electric filters, function, frequency, electronic devices, amplitude-frequency characteristic, phase, circuit

**Introduction**

ElectroMagnetic Compatibility of electronic tools is a difficult technical problem to solve which there are no universal methods. Moreover, due to the complex nature of the problem in general, this problem can be effectively addressed only the simultaneous application of system integrators, circuit design, engineering and technological methods to improve the performance of electronic and electrical tools.

In ensuring electromagnetic compatibility plays an important filtering role. The sources of noise filtering is performed in order to prevent the spread of unwanted electromagnetic waves beyond the device - the source of interference in any external connections. Feature of the filter is wide frequency range of possible interference and related challenges in implementing the filters. Advances of technology miniaturization of electronic devices have caused displacement of the interests of developers from the usual equipment of passive filters to active implemented as a rule, based on operational amplifiers, which provides greater accuracy and robustness of the equipment and can achieve significant gains in its volume and mass characteristics.

As is known, the electric filter is designed to highlight the desired signal and the transmission of mixture of useful and unwanted signals. In fact, electric filters are so common in modern technology, it is impossible to present any electronic device of intermediate complexity, which would not have used a filter in one form or another.

Design and development of the filter depends heavily on what its characteristics must be obtained, in particular frequency.

Realistically achievable amplitude-frequency characteristic (AFC) must be smooth, without breaks and without strong horizontal sections, including zero.

Solution to the problem of synthesis of filter was divided into two phases [1]:

- finding the transfer function  $W(s)$  implemented by the filter providing specified response requirements;
- development of structure and its filter concept.

The second stage is more complicated, and besides, it is ambiguous. The same transfer function corresponds to set of structures of filters based on certain ideas and circuit design using a different element of the base [2].

Despite the large volume of existing software products designed to facilitate a developer of electronic devices, development of electrical filters has not been automated yet, and requires a

considerable amount of time and is usually the method of analysis, in which the developer of electronic device takes as a basis for some basic scheme analyzes its performance and consistently making certain adjustments, is seeking to end the desired result.

### Technique of modeling and software

In this regard, the task of developing system for synthesizing electric filters which creates the required electronic circuits on mathematical model that continues to be relevant and must be addressed. Thus, the main task of article, in an asset which should be developed automatic synthesis of active electric filters on the basis of their mathematical models provided by the linear transfer functions, user-friendly for its algorithmic implementation. Each filter must be implemented to operational amplifiers, resistors and capacitors. All elements of the filter should be linear, focused and time-invariant. To achieve this goal it was made the following tasks:

- module concept synthesis filter;
- module for calculating parameters of filter elements;
- manual system.

Mathematical model of the filter was represented by two systems of equations. The first system is actually mathematical model of the designed filter in the form of linear differential equations. The solution of this system allows you to identify the current in the circuit state variables. The second set of equations determines the dependence of the output filter parameters on the phase variables [3]. Filter transfer function represented  $W_0$  in form:

$$W_0(s) = W_1(s) * W_2(s) * ... W_n(s), \quad (1)$$

where  $W_i(s)$  - transfer function of the  $i$ -th model of the dynamic link. In the synthesis of filter is used non filter frequency response, and the logarithmic amplitude-frequency characteristic (LAFC), the unit which is the decibel (dB).

LAFC filter is expressed through LAFC typical dynamic elements in the form of:

$$20\lg|W_0(j\omega)| = 20\lg|W_1(j\omega)| + 20\lg|W_2(j\omega)| + \dots + 20\lg|W_n(j\omega)|. \quad (2)$$

Occurrence of certain types of dynamic elements of mathematical model of filter is determined by angles of inclination  $\alpha$  (dB / decade). LAFC typical dynamic elements to the frequency axis, the cutoff frequency  $\omega_{sr}$  (break points LAFC typical dynamic elements) and the overall gain to the filter, which are input parameters of the mathematical model.

Using semi-log plane with the frequency axis - axis of abscissa and amplitude - the ordinate is divided into sub-bands within the specified cutoff frequency, and spending it on geometric model addition LAFC dynamic elements, we make only LAFC filter [4].

### Discussion of results

Calculation of parameters of elements forming the filter shall be in accordance with the concept of a filter synthesized on the basis of the schematic of the unit cells. After running the application on FilterSynthesis it appears the main window, shown on Figure 1.

At the initial stage of designing the user is prompted to enter the following inputs:

- presence in the transfer function of filter units of pure differentiation or pure integration;
- the gain of filter, and the entered value must lie in the range from 0.1 to 10;
- cut-off frequency and the inclination of the logarithmic amplitude-frequency characteristics of typical dynamic elements forming the filter transfer function (Figure 2).

In this case the cutoff frequency of each successive unit must be entered more than the previous rate (except for the units clean and clear differentiation of integration, which are introduced in the first place), and the total angle of inclination can not be greater than zero.

After all settings are entered, you can proceed directly to the synthesis filter. To do this, click the button "Synthesis".

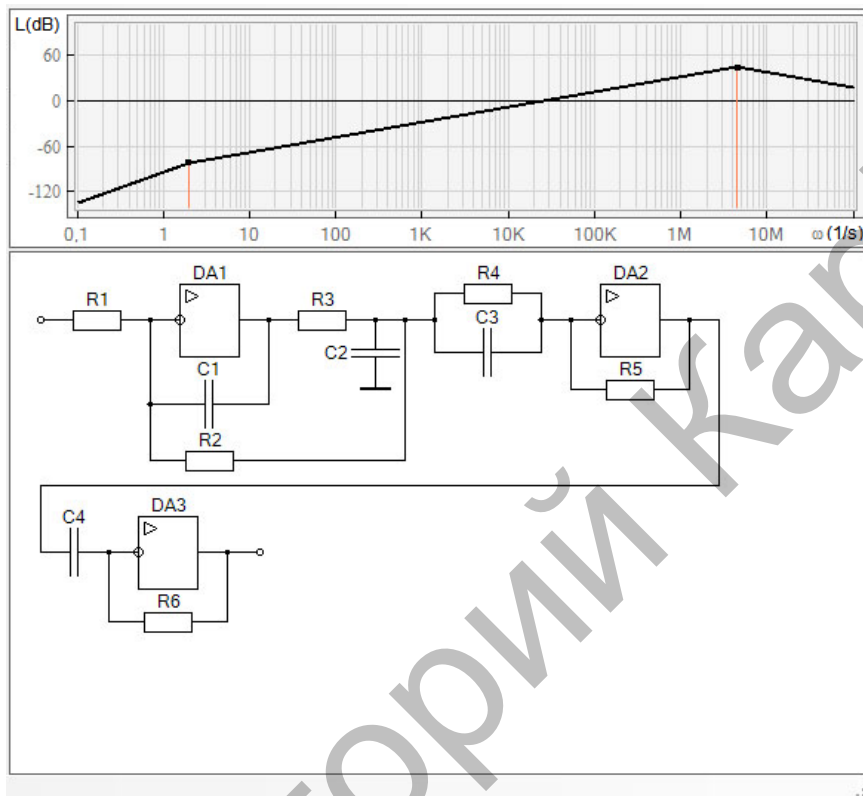

Fig.1. The main window

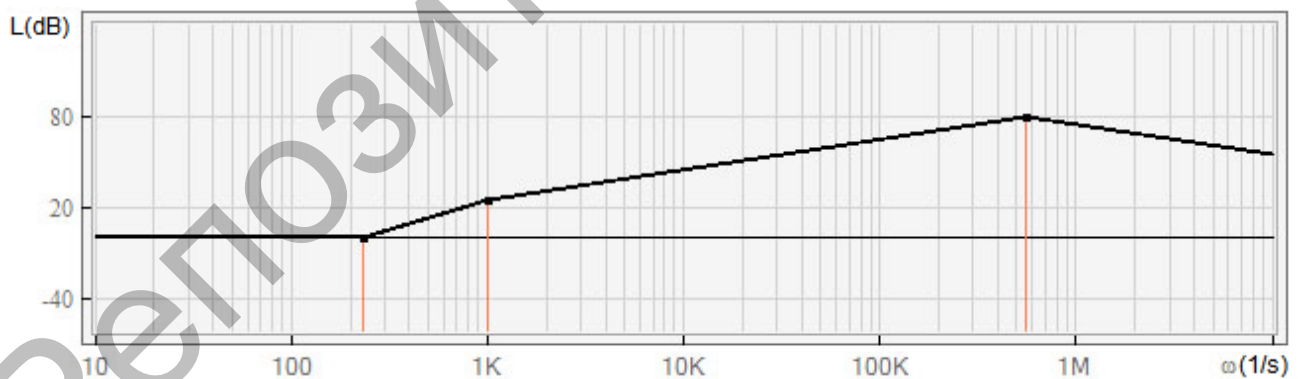

Fig.2. The logarithmic amplitude-frequency characteristic of filter

In the case of incorrectly entered data on screen, a dialog box "Error" appears with the error. For simplicity, we fix the incorrect data will be highlighted in red. If the source data is correct and the filter is realizable, then the workbench filter synthesizes and displays the results on screen in the form of the principal electric circuit filters and logarithmic amplitude-frequency characteristics (type of output information is shown in Figures 2, 3).

After completion of synthesis filter, the user has the possibility to calculate the parameters of elements included in it. To do this, click on bottom "Calculate" (Figure 1). In this case, the monitor window appears enter ratings of capacitors, which is carried out with respect to the calculation of

the parameters of the other elements of the scheme. In the table on the left side, indicated by the number of capacitors synthesized circuit required for entry to the cutoff frequencies of cells in which they belong. Denominations of capacitors can be manually entered directly into a table, or double-click to select the table denominations represented in the right pane. In this case the recommended ratings of capacitors for crossover frequencies in the range (1 - 10k) 1 / s are uF, for crossover frequencies (10k - 1 M) 1 / s - nF, and for the cutoff frequencies > 1M1 / s - pF

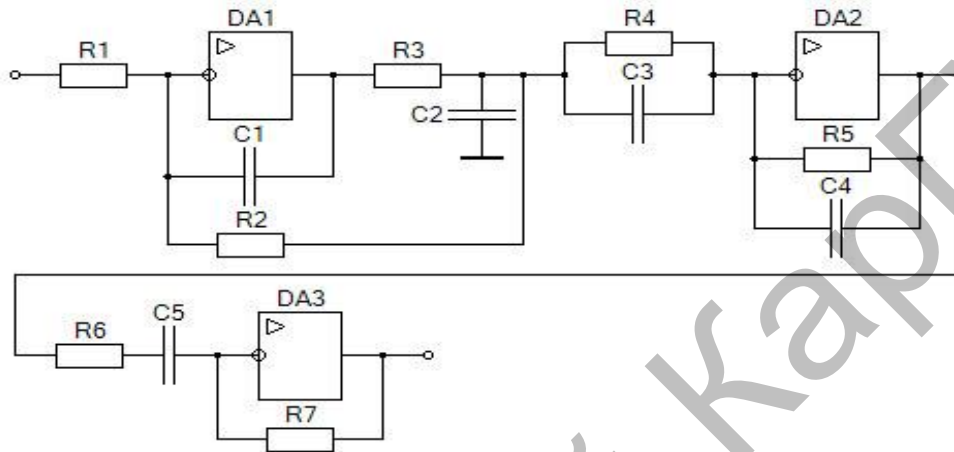

Fig.3. The electrical circuit scheme of filter

After clicking "Calculate" workbench computes the parameters of remaining elements of filter and displays them on the previously obtained a schematic diagram (Figure 4).

In accordance with the task in the process of performing this work was developed workbench is designed to automate the process of synthesis of linear active electric filters for given transfer function, that is, their cutoff frequencies, angles of inclination of the logarithmic amplitude-frequency characteristics and gain.

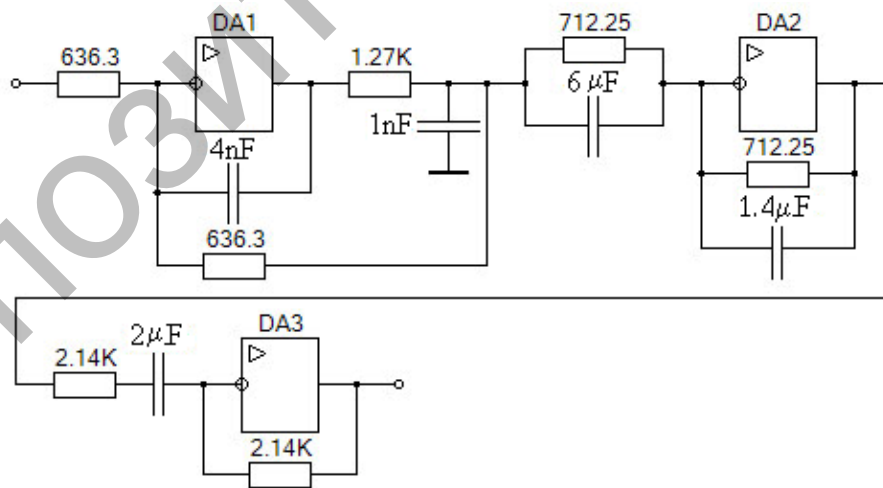

Fig.4. Schematic diagram of filter with the selected items

The developed tool environment allows you automatically:

- to construct the amplitude-frequency characteristics of the designed filters;
- get schematics of filters;
- to calculate the parameters of filter elements.

As a result of literature review direct counterparts developed the tool environment has been identified. The work of most of the closest to the developed tool environments: Electronic Workbench, MATLAB, DesignLab 8,0, Super-Compact, APLAC 7.0, Micro-Cap, - based on the analysis contained in the libraries of ready circuit design and by type of tasks to be solved in achieving the goals posed in the introduction of this article.

### **Conclusion**

Presented in the algorithm can synthesize RC-filters, but on further expanding the base of unit cells will implement schematics filters of any structure, both active and passive.

As a programming language we used language C ++, characterized by greater functionality and affordability.

Implementation of decisions does not require special expensive equipment, and we achieved for personal computer using a standard configuration of the operating system Microsoft Windows XP SP2 and the basic software Visual Studio 2008 Professional Edition, which allows you to create quickly connected applications and providing ample opportunities for the user.

The developed tool environment is easy to use and does not require any deep expertise in circuit design of electronic devices.

### **REFERENCES**

1. Volovich G.I. *Circuit design of analog and mixed-signal devices*. Moscow, Dodeka-XXI publ., 2005, 528 p.
2. Lem G. *Analog and digital filters*. Moscow, Mir Publ., 1982, 592 p.
3. Ivashenko N.N. *Automatic regulation. Theory and elements of system*. Moscow, Mashinostroenie Publ., 1973, 736 p.
4. Tronin Y.V., Gursky O.V. *Synthesis of filter*. Moscow, MAI Publ., 1990, 76 p.

Article accepted for publication 21.04.2014