

M.Z. Yakubova¹, V.P. Razinkin², T.G. Serikov³, A.K. Muratova⁴

¹Almaty University of Power Engineering & Telecommunications;

²Novosibirsk State Technical University, Russia;

³Kazakh National Technical University, Almaty;

⁴Karaganda State Technical University

(E-mail: mubor149@rambler.ru)

Research of production errors' influence on characteristics of the microstrip antenna

Modern microstrip antennas provide high repeatability of the sizes, low cost, small metal consumption, overall dimensions and weight. The main problem of such Microwave technique's production is ensuring the set accuracy. This article represents the calculations and schemes proving casual deviations of the antenna's geometrical size from the required settlement. As the program for modeling and calculation of the microstrip antenna's parameters we used MathCAD. By results of a research it has been proved that the above-stated deviations lead to mistakes in distribution of currents on the surface of the antenna and change of its characteristics of radiation.

Key words: microstrip antenna, wave resistance, rejection, defect, face crack.

Wireless communications play a significant role in our life. They allow to get rid of bulky and expensive cable infrastructure, provide communication channels where laying of cables and other guides of systems is impossible or inexpedient. Nowadays are the century of rapid development of wireless technologies access, such as Wi-Fi, networks of cellular communication of the second, third, fourth and, in close prospect, the fifth generation, networks of satellite communication, radio channels play very significant role in telecommunications. Besides access for subscribers to networks wireless channels play a role of the main channels in radio relay and satellite communication. They are used for TV and radio broadcasting and perform still a number of important functions.

An important role in a wireless communication is played by antenna-feeder devices. Antennas are the devices transforming the electromagnetic oscillations going from the transmitter to an electromagnetic wave which extends in space and vice versa, the accepting electromagnetic waves from space and transforming them to electromagnetic oscillations which are transferred to the receiver. Thanks to the directed properties of the antenna concentrate energy of electromagnetic waves in the necessary directions that provides increase in range of transfer and reception at the equal capacities of transfer, and also provide the best electromagnetic compatibility with other send-receive devices. There is a large number of the antennas' kinds which are characterized by ranges of frequencies, characteristics of an orientation, overall dimensions, etc.

Microstrip antennas are one of the modern kinds of antennas. It is a piece of the microstrip line which is used as a radiator. Distinctive features of these antennas are their small dimensions, technological effectiveness of production, narrow-band, small cost. Microstrip antennas are widely used in the aircraft, space equipment, and also find application as antennas for strengthening of wireless data transmission's some standarts (for example, Wi-Fi). This type of antennas is applied in the range of ultrahigh frequencies.

The important characteristic of the antenna is extent of its coordination with the line of power. The antenna mismatch with the line leads to increase in energy of the reflected waves and reduction of the antenna's efficiency. For coordination of the antenna its overall dimensions select such that the active component of entrance resistance was equal to the wave resistance of the line, and the jet component was equal (or it is close) to zero.

In the course of mass production errors at production of antennas are possible. Owing to the small size of radiators and features of waves' radiation in the microwave oven range even the small mistake can lead to inadmissible deviations of antennas' parameters. For this reason it is necessary to provide high precision of the antenna's production. However high-precision production is more expensive therefore it is necessary to select accuracy parameters according to objectives.

We consider a microstrip radiator of rectangular type (Fig. 1). Its length b is 39,09 mm, width a is 37 mm, power point shift from edge of a radiator utp is 6,8 mm. Thickness of a substrate h is 3,1 mm, material SAM-ED with relative dielectric permeability $\varepsilon=2,5\pm 0,1$, the size of a tangent of dielectric losses $\delta = 6 \times 10^{-4}$. This radiator is constructed so it is coordinated with the line with a resistance of 50 Ohms that is

standard value of wave resistance for the used transmission lines. Entrance resistance of a radiator makes $50,441-0,173i$ Ohm at a frequency of 2438 MHz at these sizes. This frequency corresponds to the middle of the 6th frequency channel of the IEEE 802.11 n. standard's radio interface.

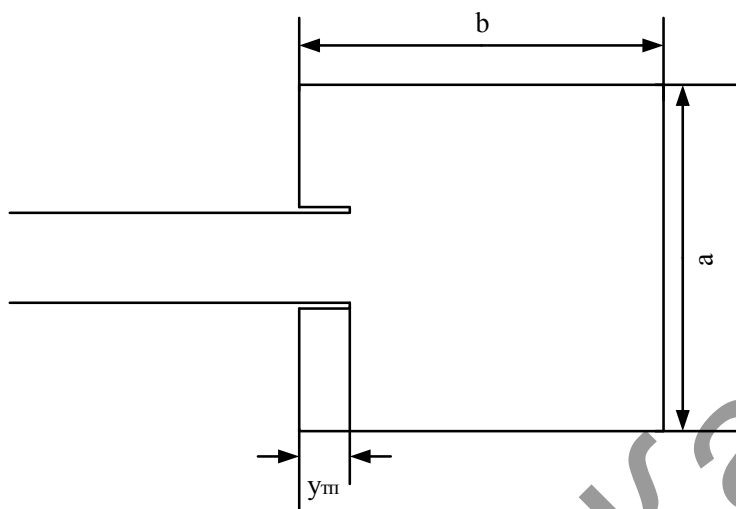

Figure 1. Microstrip radiator

For determination of entrance resistance of a radiator consider the radiating element's equivalent scheme. According to this scheme the rectangular radiator is presented by a piece of the equivalent two-wire line which is loaded on conductivity of face cracks (Fig. 2) [1].

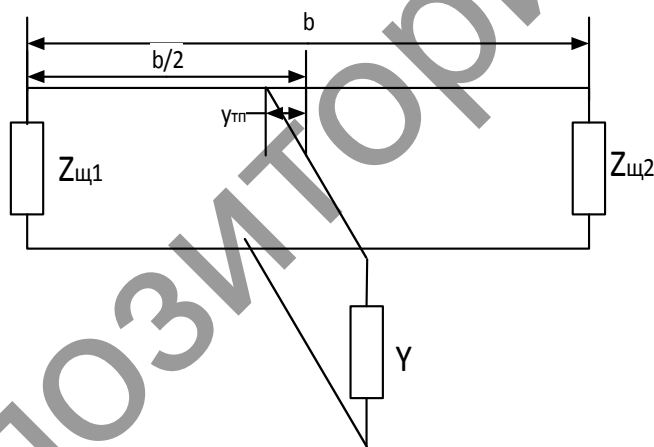

Figure 2. Equivalent circuit

Data of conductivity are complex. The exciting strip line is presented as the parallel jet resistance and the ideal transformer. The coefficient of transformation of this transformer is believed equal to unit, and parallel reactivity equal to zero. Then the entrance resistance of a radiator will be equal:

$$Z_{in} = R_{in} + iX_{in} = \frac{Z_1 * Z_2}{Z_1 + Z_2}, \text{ Ohm}, \tag{1}$$

where Z_1 is the entrance resistance of a piece of the two-wire line length of $b/2 - y_p$ which is loaded on resistance of a face crack of Z_{cr1} , Ohm (2); Z_2 is the entrance resistance of a piece of the equivalent two-wire line, length of $b/2 + y_p$ loaded on resistance of a face crack of Z_{cr2} , Ohm (3).

The corresponding resistance are from formulas (2) and (3) [1]:

$$Z_1 = Z_{wave} \frac{Z_{cr1} + iZ_{wave} * \operatorname{tg} \left(\beta \left(\frac{b}{2} - y_{tp} \right) \right)}{Z_{wave} + iZ_{cr1} * \operatorname{tg} \left(\beta \left(\frac{b}{2} - y_{tp} \right) \right)}, \text{ Ohm}, \quad (2)$$

where Z_w is the wave resistance of the strip line without losses, Ohm; β is a distribution constant quazi- T waves $m-1$; y_{tp} is the shift of a point of food of rather average point m ; Z_{cr1} is a resistance of the first face crack, Ohm.

$$Z_2 = Z_{wave} \frac{Z_{cr2} + iZ_{wave} * \operatorname{tg} \left(\beta \left(\frac{b}{2} + y_{tp} \right) \right)}{Z_{wave} + iZ_{cr2} * \operatorname{tg} \left(\beta \left(\frac{b}{2} + y_{tp} \right) \right)}, \text{ Ohm}, \quad (3)$$

where Z_{cr2} — resistance of the second face crack, Ohm.

The distribution constant quazi- T waves is according to (4):

$$\beta = k_0 * \sqrt{\epsilon_{ef}}, \text{ m}^{-1}, \quad (4)$$

where k_0 is a wave number, ϵ_{ef} is an effective dielectric permeability of the environment. We find these sizes on formulas (5) and (6) [2]:

$$k_0 = \frac{2\pi}{\lambda_0}, \text{ m}^{-1}, \quad (5)$$

where λ_0 is a length of wave.

$$\epsilon_{ef} = \frac{\epsilon + 1}{2} + (\epsilon - 1) \frac{\left(1 + \frac{12h}{a}\right)^{-\frac{1}{2}}}{2}, \quad (6)$$

where h is a dielectric thickness, ϵ is dielectric permeability of material of dielectric.

We find wave resistance from a formula (7) [2]:

$$Z_{wave} = \frac{60\pi}{\sqrt{\epsilon}} \left(\frac{a}{2h} + 0,44 + \frac{0,082(\epsilon - 1)}{\epsilon^2} + \frac{\epsilon + 1}{\epsilon} \left(0,231 + 0,159 \left(\frac{a}{2h} + 0,94 \right) \right) \right)^{-1}. \quad (7)$$

Resistance of cracks can be learned from their conduction. Conduction of cracks we calculate according to a formula (8):

$$G_{cr} = \frac{\pi a}{\lambda_0} \sqrt{\frac{\epsilon_0}{\mu_0}} (1 + i * (1 - 0,276 \lg(k_0 * h))), \text{ cm}, \quad (8)$$

where ϵ_0 , μ_0 are absolute dielectric and magnetic permeability ($\epsilon_0 = 8,85 \cdot 10^{-12}$ F/m, $\mu_0 = 4 \cdot \pi \cdot 10^{-7}$ H/m).

Resistance in this case is equal to (9):

$$Z_{cr} = \frac{1}{G_{cr}}, \text{ Ohm}. \quad (9)$$

It is possible to calculate the entrance resistance of the microstrip antenna by using above-mentioned formulas. Coherence of the antenna with a transmission line and its efficiency depends on this size. Degree of coherence can be found out from reflection coefficient. So it has better coordinated the antenna than it is less. The coefficient of reflection p is connected with the coefficient of the running wave (CRW) by a ratio (10):

$$p = \frac{1 - CRW}{1 + CRW}. \quad (10)$$

We accept as admissible p equal to 0,1 value. It corresponds to CRW equal to 0,818 that is admissible for a wide range of tasks.

Value p is from the entrance resistance of the antenna and wave resistance of the line according to (11):

$$p = \left| \frac{Z_{in} - Z_l}{Z_{in} + Z_l} \right| \quad (11)$$

We make taking note of errors by means of the Monte Carlo method. The essence of a method consists in receiving a large number of a random variable realization which is formed as also a real random variable in a task. It is possible to draw conclusions how the random variable in general influences process by having received a large number of realization.

We accept antenna length b as a random variable. We set an error in 1 %. We accept b as the random variable distributed under the normal law with population mean in 39,09 mm and the mean square deviation equal 1/3 from an absolute value of an error. Such size is entered for a reason that 99,73 percent of normally distributed values' deviations random variable from population mean get to an interval from three mean square deviations (the rule three sigma). Therefore if size b possesses such mean square deviation then absolutely most part of the made antennas will correspond the set error.

We make modeling in the environment of mathematical algebra MathCAD [3]. For a task of a random variable of b we use the rnorm function (n, A, σ) where n is number of values of a random variable, A is maths expectation, σ is a mean square deviation. This function removes a matrix column with normally distributed values according to the set parameters. The window of calculations is presented by MathCAD in the Figure 3:

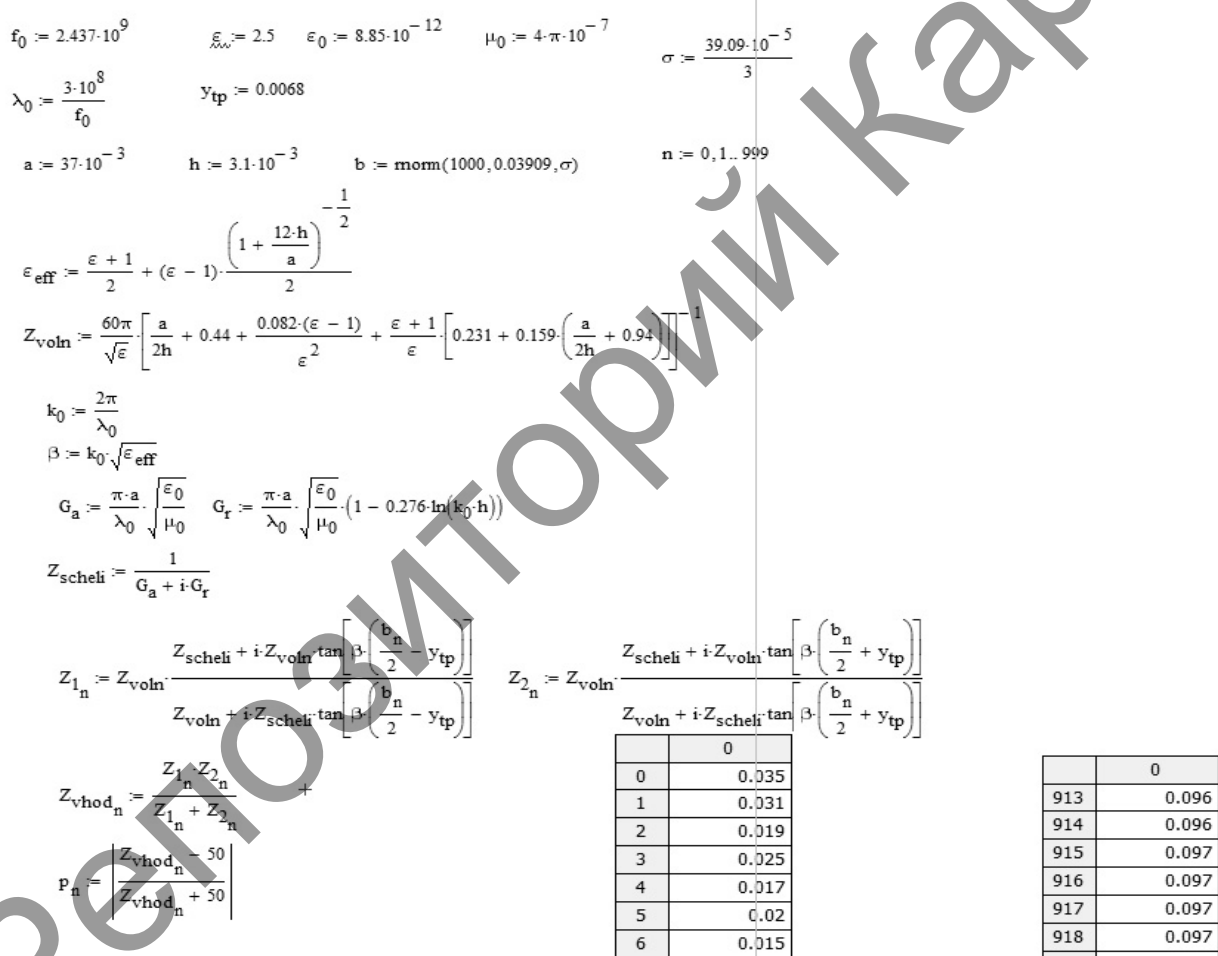

Figure 3. Window of calculations in MathCAD

As a result we receive a matrix, there are a column b from 1000 values of size b and p matrix column with values of reflection coefficient's size for preset values b from the corresponding matrix. We make 5 experiments for 1000, 10000 and 100000 values of a random variable b . After sorting by the «sort» team we can see from 1000 values in the first experience 74 values above, than the limit specified earlier, in the second is 79, in the third is 82, in the fourth is 65, in the fifth is 83. We consolidate these data, and also data for 10000 and 100000 values in Table 1:

Table 1

Results of experience

Amount of selection	1st experience	2nd experience	3rd experience	4th experience	5th experience
1000	74	79	82	65	83
10000	784	849	836	799	817
100000	8025	7989	8014	8098	7969

We make statistical processing of the obtained data. Let's reduce the received results in Table 2:

Table 2

Results of statistical processing for an error in 1 %

Amount of selection	Maths expectation	Rejection rate, %	Mean square deviation absolute	Relative mean square deviation
1000	76,6	7,66	6,591	0,086
10000	817	8,17	23,656	0,029
100000	8019	8,019	44,05	0,0055

The most exact value is the last what tells small value of a mean square deviation about. Thus, we receive about 8 percent of marriage at a production error in 1 %.

We conduct similar experiment for an error in 0.5 %. The obtained data are consolidated in Table 3:

Table 3

Results of statistical processing for an error in 0,5 %

Amount of selection	Maths expectation	Rejection rate, %	Mean square deviation absolute	Relative mean square deviation
1000	0,4	0,04	0,49	1,225
10000	5,6	0,056	1,02	0,182
100000	51,4	0,0514	4,5	0,088

With such accuracy measurement of defect's percent from 1000 values b is very inexact. In fact, from 2 experiences marriage in 1 case from one thousand had been received, in three other experiences defect wasn't and all values had got an admissible limit.

From the table, reduction of an error has twice led to reduction of defect by 156 times. It speaks about need in ensuring high precision by production of microstrip antennas. Modern technologies of creation of microstructures allow to achieve very high precision that allows to create very exact printing designs.

References

- 1 Антенны и устройства СВЧ. Проектирование фазированных антенных решёток: учеб. пособие / Под ред. Д.И. Воскресенского. — М.: Радио и связь, 1994. — 592 с.
- 2 Панченко Б.А., Нефёдов Е.И. Микрополосковые антенны. — М.: Радио и связь, 1986. — 144 с.
- 3 Очков В.Ф. MathCAD 14 для студентов и инженеров: русская версия. — СПб.: BHV, 2009.

М.З. Якубова, В.П. Разинкин, Т.Г. Сериков, А.К. Муратова

Микрожолқты антеннаның сипаттамаларына өндірістік қателердің әсерін зерттеу

Мақалада қазіргі заманғы микрожолқты антенналар өлшемдерінің кең көлемде көшірілімдерінің жасалуын, аз құнды, металды көп қажет етпейді, ірі өлшемдер мен массаны қамтамасыз етеді. Мұндай жоғары жиілікті техниканы жасаудың басты проблемасы берілген дәлдікті қамтамасыз ету болып табылады. Авторлар антеннаның геометриялық өлшемдерінің кездейсоқ ауытқуларын дәлелдейтін

есептеулер мен сұлбаларын ұсынды. Микрожолакты антеннаның параметрлерін, сұлбалар мен есептеулерді модельдеу үшін негізгі бағдарлама ретінде MathCAD бағдарламасы қолданылды. Зерттеу нәтижесінде жоғарыда айтылған ауытқулар микрожолакты антеннаның бетінде токтың үлестіруінде және оның сәуле шығарудың сипаттамаларын өзгеріске ұшырататыны дәлелденді.

М.З. Якубова, В.П. Разинкин, Т.Г. Сериков, А.К. Муратова

Исследование влияния производственных погрешностей на характеристики микрополосковой антенны

Современные микрополосковые антенны обеспечивают высокую повторяемость размеров, низкую стоимость, малые металлоемкость, габаритные размеры и массу. Главная проблема изготовления такой СВЧ техники — обеспечение заданной точности. В статье даны расчеты и схемы, доказывающие случайные отклонения геометрических размеров антенны от требуемых расчетных. В качестве программы для моделирования и расчета параметров микрополосковой антенны использована MathCAD. По результатам исследования доказано, что указанные выше отклонения приводят к ошибкам в распределении токов по поверхности антенны и изменению ее характеристик излучения.

References

- 1 *Antennas and microwave ovens devices. Design of the phased antenna lattices*: Education guidance, Ed. by D.I. Voskresensky, Moscow: Radio i svyaz', 1994, 592 p.
- 2 Panchenko B.A., Nefyodov E.I. *Microstrip antennas*, Moscow: Radio i svyaz', 1986, 144 p.
- 3 Ochkov V.F. *Mathcad 14 for students and engineers: Russian version*, Saint Petersburg: BHV, 2009.