

UDC 621.438.001.8

TO THE METHODOLOGY OF THE RESEARCH OF THE GTE TURBINE BLADES PLATFORMSWEAR

Ivshchenko L.I., Pribora T.I., Komochkin N.S., Sakhnyuk N.V.

Zaporizhzhya National Technical University, Ukraine, nkomochk@zntu.edu.ua

The problem of the gas turbine engine turbine blades platforms wear is discussed. The methodology to solve this problem by defining the processes that occur in platforms is suggested. The object model test and research methods are described. Describes the object modeling techniques and explore patterns of oscillations of the system of coupled oscillations of parts of an aircraft engine turbine. An original setting for the study of the wear of rotor blades was used.

Keywords: wear, platforms, blades, turbines, gas turbine plant.

Introduction

Many compounds of machinery parts in use are under complex loading. This is due to the mutual movements of the functional surfaces in various directions, vibrations, presence or combinations thereof. The consequence of this process is the inevitable wear of the working surfaces of joints. Largely dimensional stability and consistent quality surface determine the resource of individual parts and machinery in general. Question increase wear of contact surfaces of the parts are not lost its relevance today. In various branches of engineering it is solved by the use of more high-quality and expensive structural materials, wear-resistant coatings, and appropriate heat treatment to achieve a certain surface quality in their manufacture. In recent years, scientists are placing more emphasis on the relationship surface engineering and operating conditions of parts. The object of our study are tribomating who work in a complex dynamic loading in combination with a wide range of operating temperatures and speeds. The study of such a system requires a comprehensive approach.

1. Formulation of the problem

Design, technological and strength features of the turbine working blades of the gas turbine engines (GTE) influence largely their gas dynamic characteristics. The turbine blades are the most loaded, essential parts of the massively produced gas turbine plants. In terms of construction, the blades consist of a working part (blade airfoil), root designed for mounting a blade on the wheel, and platforms (Fig.1) responsible for the oscillation stabilization of the blade row and the whole turbine. To improve the gas-dynamic characteristics of the GTE, the stringent requirements on elements wear-resistance, cyclic fracture, corrosion resistance at high temperatures, static resistance, etc. are imposed on the working turbine blades.

In modern aircraft GTE, platform connections of various designs whereby the working turbine blades are combined into a closed circular system are widely used to improve the reliability and durability of the blades. It reduces the rotor sensitivity to vibrations, provides the necessary damping level of vibratory load son the airfoil blade; moreover it reduces the losses of the working gas through the radial gaps between the rotor and the stator, consequently increasing the turbine efficiency. The platforms contact surface work under cyclically varying high temperatures, aggressive gas medium and dynamic loadings. According to the work [1], the platforms are under contact pressure of forces P , (which is perceived from adjacent platforms), torque M from these forces, and the frictional force T (see Fig. 2a).

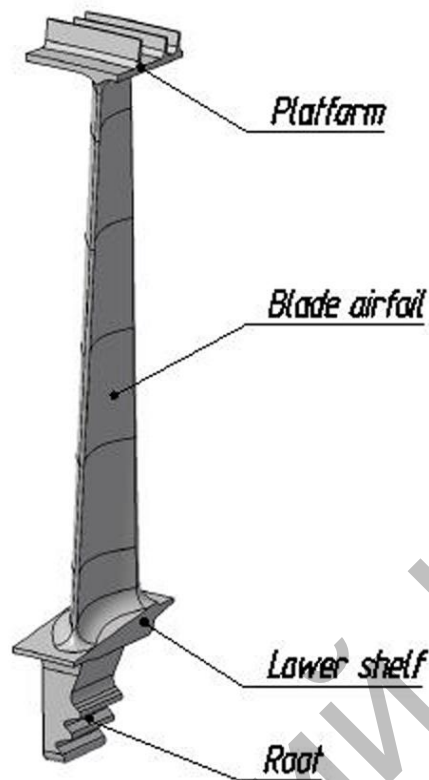

Fig.1. The working blade of the GTE turbine rotor

However, one cannot claim that the platforms surfaces contact will be kept throughout the entire operating time. The increase in the operating temperature, blades growth stretching caused by centrifugal force, the change in the position of platforms contact surfaces with vibrations of various forms will inevitably lead to the gaps emergence S , collision with power P and the following sliding (F – force of sliding friction) (see Fig. 2b).

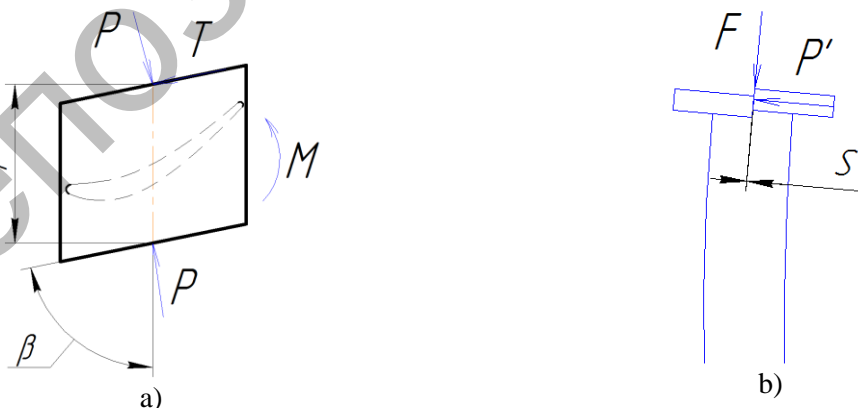

Fig. 2. Forces acting on the platform during operation

Despite significant preload, compressing platforms of adjacent blades, the latter do not remain stationary relative to each other at work. The platform displacement, caused by oscillation of the “shaft-disc-blades” system, leads to a significant wear of their working surfaces.

The analysis results of platforms wear measurement results (the platforms of shrouded pairs of the working blades after 2998 test hours (Fig. 3)), shows that the shrouded platforms wear of the left and right blades is rather uneven. It ranges from 0.005 to 0.130 mm.

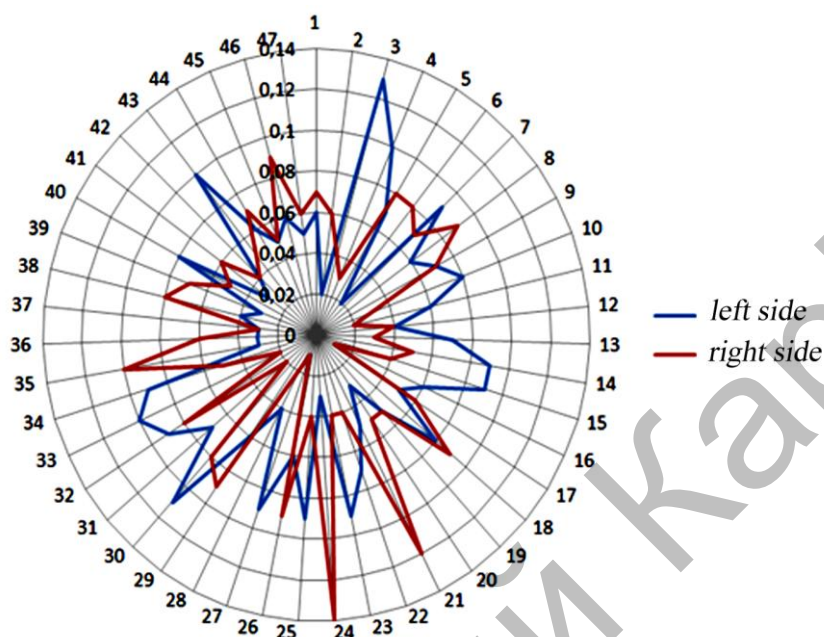

Fig.3. Actual wear of the contact surfaces of the turbine working blades platforms

Such unevenness is caused by the action of the loads in the system of the mutually superimposed oscillations of the parts, forming the turbine rotor (turbine shaft, disk and blades vibration). At the moment of the parts resonant oscillation, the amplitude of the blades oscillation as the final link, taking the vibrations of the entire system, increases by many times. This will lead to the amplitude of the platforms displacement and the contact loads, hence the platforms wear will be maximized.

To date, the decision on reducing the degree of platforms wear is possible due to the usage of wear resistant coating of the platforms contact surface, as well as to reducing the oscillation amplitude and reduction of pressure in the contact using constructive-technological methods. However, the most promising, in our view, could be a resonance oscillation elimination method in the “shaft-disc-blade” system, due to the natural frequency detuning of the system parts oscillations.

The aim of this work is to simulate the loading condition of the platforms based on the laws of “shaft-disc-blade” system oscillation and the development of a physical model for the study of the tribological processes in the contact zone.

2. Object model test and research methods

The modern methods of coupled oscillation calculation are used to determine the patterns of oscillation of the “shaft-disc-blade” system by means of the three-dimensional model of the GTE turbine rotor (Fig. 4). Modern GTE turbine rotor is a complex contraction consisting of structural elements of different stiffness, made from different materials. The considered system includes a rotor shaft and a blade wheel, equipped with twin moving blades, closed into a ring by means of platforms. To investigate the vibration stress state of the system under the influence of the forces applied, with the consideration of the impact of physical and geometrical design parameters, material properties, rotor speed and operating temperature, the numerical computational methods such as finite element method (FEM) are used.

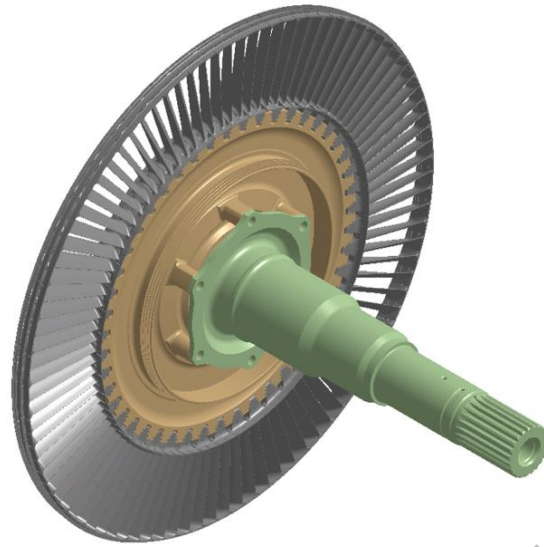

Fig.4. The three-dimensional model of the GTE turbine rotor

The three-dimensional models use allows obtaining accurate displacement amplitudes values of the nodal points of the moving blades platforms contact surfaces with the consideration of the main construction loading factors. The construction of the GTE turbine rotor design model, setting of the loading factors, as well as providing the ability to investigate the design elements concurrent working in the multiply-connected finite element model and using the contact elements allows bringing the estimated vibration stress state of the node to the real one.

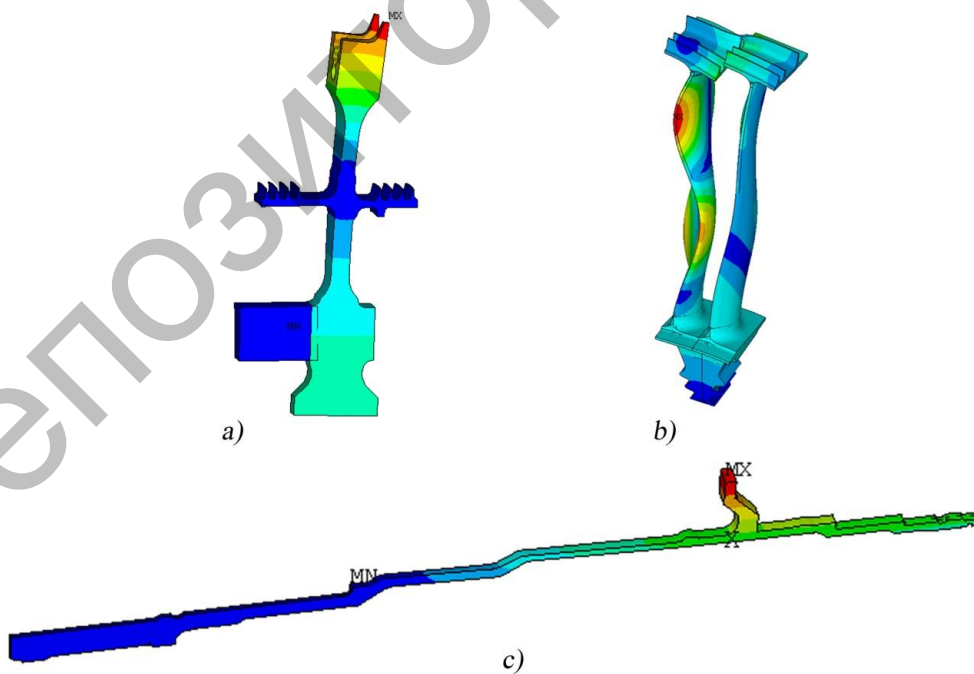

Fig.5. The analysis of the finite element models of the III step disc, left and right blades, and the LPT shaft: a) Disc; b) Blades; c) Shaft

We have created the three-dimensional models of the left and right blades, the III step disc and the low pressure turbine (LPT) shaft. The finite element models of these parts (Fig. 5) were generated by ANSYS software environment. The static and modal analysis of the unit assembly and the parts were held incoming. Independently the displacement amplitude of the platform blades nodal points was calculated. On analyzing the data, we get a picture of the nodal points' displacement in the three directions depending on the value of natural oscillation frequency of the parts (Fig. 6).

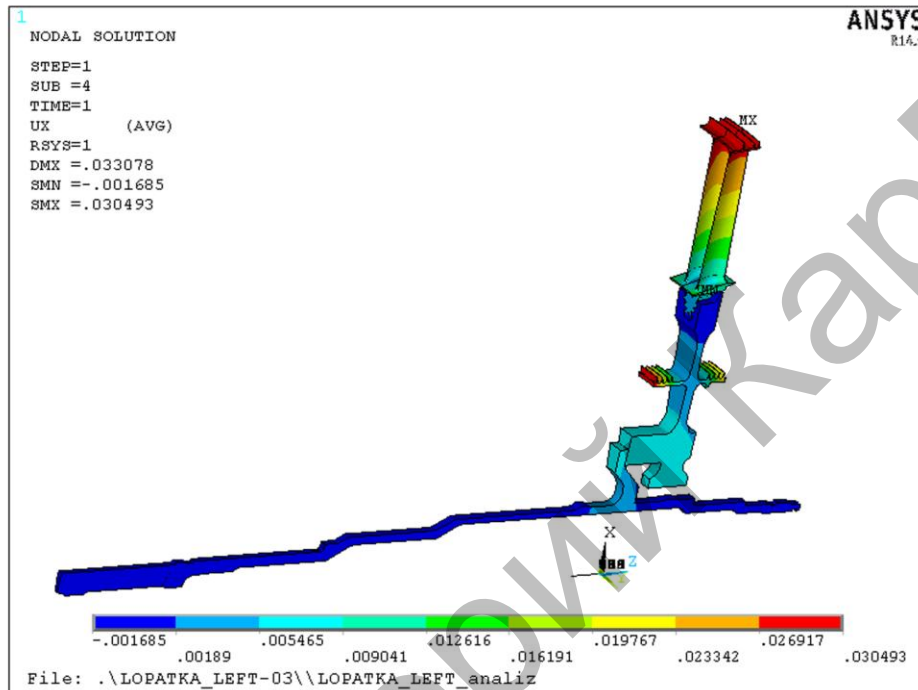

Fig.6. The analysis of the finite element models of the assembled turbine

The displacements amplitudes values of characteristic points of the blades platforms contact surfaces are used to determine the contact pressure in the contact areas, which are the initial load parameters in the wear analog modeling (Fig.7). The slip in the two orthogonally related directions is provided by the spring plate clips twist. At the same time, it imposes a constraint conforming the motion of the samples with different degrees of freedom, so that the ratio rating of these movements remains constant, due to the elastic properties of the spring clips.

The plant consists of the oscillation amplitude setting unit 1, samples attachment lug 2, and the load setting unit 3. The load setting unit 3 contains the lever 4, which is pivotally connected to the thrust rod 5 with the load spring 7 on it, connected to the stepper motor 8 via the thrust washer 6 through feed nut assembly. The samples attachment lug 2 includes cantilever fitted spring plate clips 10. They have a twist and can contain of the cross-section area a variable height and width. There are struts 11 parted by the roller 9 on the clips. Also there are samples 12 which are fixed on the struts. The longitudinal oscillation amplitude setting unit 1 consists of the cam 15 connected by coupling with the electric motor 13. By dint of the feed nut assembly the stepper motor 14 is connected through the roller 16 to the samples attachment lug 2. The plant is also equipped with the electronic unit 18 and the temperature setting unit chamber 19.

The samples are installed in the struts of the samples attachment lug. The constant distance between them in movable and immovable states is provided by the roller which also excludes the deflection effect of the spring plate clips on the completeness of working surfaces contact of the samples.

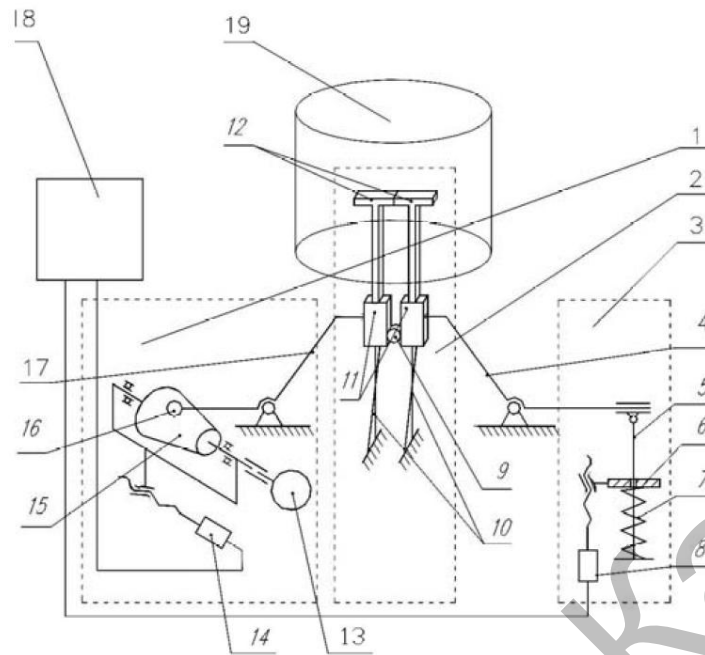

Fig.7. The scheme of the wear analog modeling: 1 –the longitudinal oscillation amplitude setting unit; 2 –samples attachment unit; 3 –load setting unit; 4 –lever; 5 –thrust rod; 6 – thrust washer; 7 – load spring; 8 – stepper motor; 9 – roller; 10 – spring plate clips; 11 – struts; 12 – samples; 13 – electric motor; 14 – stepper motor; 15 – cam; 16 – roller; 17 –tappet arm; 18 – electronic unit; 19 –temperature setting unit chamber.

A movement with the required longitudinal oscillation amplitude is provided by the amplitude setting unit. The rotation of the cam, carried out by the electric motor, results in oscillatory motion with the necessary amplitude by means of the tappet arm of the clips, struts and samples. Herewith there is a collision and sliding of the samples surfaces in the longitudinal direction. The necessary contact pressure is provided by the load transfer to samples through the lever from the load spring. It is controlled by varying the degree of compression of the latter by moving the thrust washer along the thrust rod (load setting unit). To reduce the wear of the cam 15 and pusher-arm rocker contact the roller 16 is used. The wear reduction of the cam 15 contact and the beam tappet arm is provided by means of the roller 16.

The change in the load and samples displacement amplitude directly during the test can be provided by the change in the spring compression and the displacement of the cam by using the stepper motors in accordance with a program set by the hardware control unit (electronic unit). To carry out the tests at temperatures different from room temperature, the samples are placed in the chamber with the necessary temperature. The presence of the twist and the spring plate clip areas of different stiffness gives rise to vibrations of the clips and, consequently to the samples slip in the cross-section direction. As a result, the three-dimensional loaded state of samples surfaces is realized: a kick followed by slippage in the two orthogonally related directions.

3. Discussion of results

The determination of fracture patterns upon platforms contact interaction and changing of the physical and mechanical properties of the surface layers of the samples were investigated by tribospektrum method during continuous pressing and scanning by indenter of the “Micron-gamma” device developed by the NAU Ukraine. The scan method is based on continuous registration of resistance to movement of the indenter on the surface depending on the load applied [2]. The

determination of statistical relationships between the resistance of local micro volumes of material to the contact deformation allows producing a comprehensive assessment of the state of the surface layer on the scan track and, in particular, allows evaluating the relative average strength on the scan track, assessing the dispersion and heterogeneity of the strength properties, and simulating the elementary acts of friction and wear processes.

The assessment of the surface layer of the materials, largely dependent on their electronic structure, was produced by a change in the electron work function. This method is one of the most informative ones for determining changes in the surface layer energy state of the materials that interact in friction process – the analysis of the value distribution of the electron work function (RWF) on the surface. This parameter is required in the calculation of the surface energy of solids. One of the areas of study of naturally complex physical and chemical processes is based on RWF change. That processes occur in the contact zone of the friction pairs [3].

The research methodology of tribological processes in the platforms also provides methods for determining:

- oscillation frequency of the individual elements and the entire “shaft-disc-blade” system;
- specific pressures in contact, consisting of static and dynamic components;
- platforms oscillation amplitudes;
- temperature loading mode;
- way of friction in oscillatory motions of the platforms, that is the basis of determining their wear rate.

Conclusion

High service life of turbine aircraft engines and power plants is of particular importance for the safety of human activity. At the same time the possibility of increasing the wear resistance of the contact surfaces of the parts due to the use of wear-resistant materials are practically exhausted. To date, no studies that have covered or solved the issue of increasing the wear resistance of components under the influence of the complex vibrations of complex mechanical systems. Note that the finite element method in tribotechnology still unused.

The suggested methodology allows establishing patterns of blades platforms wear at the turbine blade wheel, determining the parameters of contact interaction and their impact on the wear rate, and ultimately, offering constructive-technological methods of increasing the wear resistance of the platforms contact surfaces. Similarly, it can be investigated torbosproyazheniya of parts and components of various branches of mechanics, mechanical engineering, instrumentation, aerospace and transportation.

REFERENCES

- 1 Merkulov V.M., Ilyushchenko F.D. Development of the shrouded turbine rotor blades by taking into account the requirements of reliability and manufacturability. *Aviatsionno-kosmicheskaya tekhnika I tekhnologiya [Aerospace Engineering and Technology]*, 2006, No. 9/35, pp. 86–89. [in Russian]
- 2 Ignatovich S.R., Zakiev I.M., Borisov D.I. Damage assessment of the surface layer of materials under cyclic loading by nanoindentation and nanosclerometry methods. *Problemy prochnosti [Strength problems]*, 2006, No. 4, pp. 132 – 139. [in Russian]
- 3 Markov A.A. *Izmerenie raboty vykhoda elektrona pri trenii [Measurement of frictional electron work function]*. Moscow, Nauka Publ., 1973, pp. 28–34