

UDC 577.322

EFFECT OF OXYGEN ON THE EXCITED STATE OF COMPLEX ORGANIC MOLECULES

K. B. Kopbalina *, N.A. Mazhenov **

*Karaganda State University named after E. A. Buketov,

**Karaganda State Technical University, Karaganda, Kazakhstan, kopbalina82@mail.ru

This article provides an analysis of the electronic structure of O_2 oxygen molecule. The mechanism of quenching of aromatic hydrocarbons luminescence affected by an oxygen molecule is analysed. Since the interaction of triplet oxygen with singlet organic molecules is not possible, an analysis of interaction at excited singlet states is carried out. The interaction of the oxygen molecule with complex organic molecules at excited electron states has a number of interesting effects, the reason of which is not completely clear. It is particularly important in nanostructures, when the size of the particle interaction area is comparable to the size of the reagents. The main parameters obtained by calculation, confirming the mechanism of the spin-orbital interaction are cited.

Keywords: Oxygen, luminescence, singlet, triplet

Currently it is established experimentally that oxygen molecules have an effective quenching effect on the excited singlet (S_1) and triplet (T_1) states of aromatic hydrocarbons molecules and dyes. Quenching of excited states of luminophore by oxygen is in accordance with schemes (2) and (3) [1-6]:

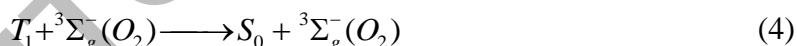
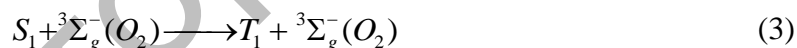
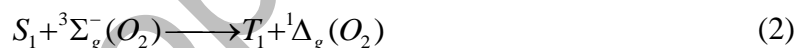
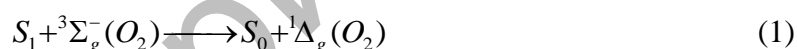

where ${}^3\Sigma_g^-$ and ${}^1\Delta_g$ are the basic (triplet) and the lowest excited (singlet) states of the oxygen molecule. During the processes (1) and (2) of oxygen molecules at the singlet state (${}^1\Delta_g$) are formed, some of them can react with the T-centers that haven't lost their integrity:

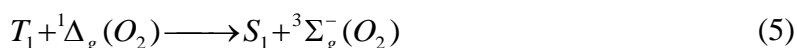

Oxygen in the air is composed of O_2 molecules mainly at the triplet state, which corresponds to the electron configuration

$$\psi = (1\sigma_g)^2(1\sigma_u)^2(2\sigma_g)^2(2\sigma_u)^2(3\sigma_g)^2(1\pi_u)^4(1\pi_g)^2 \quad (6)$$

There are four possible quantum states with a definite spin (S) and orbital (L_z) angular momenta, depending on the location of the two outer electrons on two degenerate $1\pi_g$ - molecular orbitals (MO).

The occurrence of excited singlet states with low energy (Fig. 1), as well as the intrinsic magnetic momentum of the spin at the ground state of oxygen basically determines almost all the particular characteristics of the O_2 molecule, as the major biochemical and photochemical agent in

nature [3-6]. Symbols a , b , X are used in spectroscopy by convention and taken into consideration for further notations.

Singlet oxygen is not spin-forbidden for reactions with singlet (diamagnetic) molecules and therefore exhibits great chemical activity in contrast to ordinary triplet oxygen.

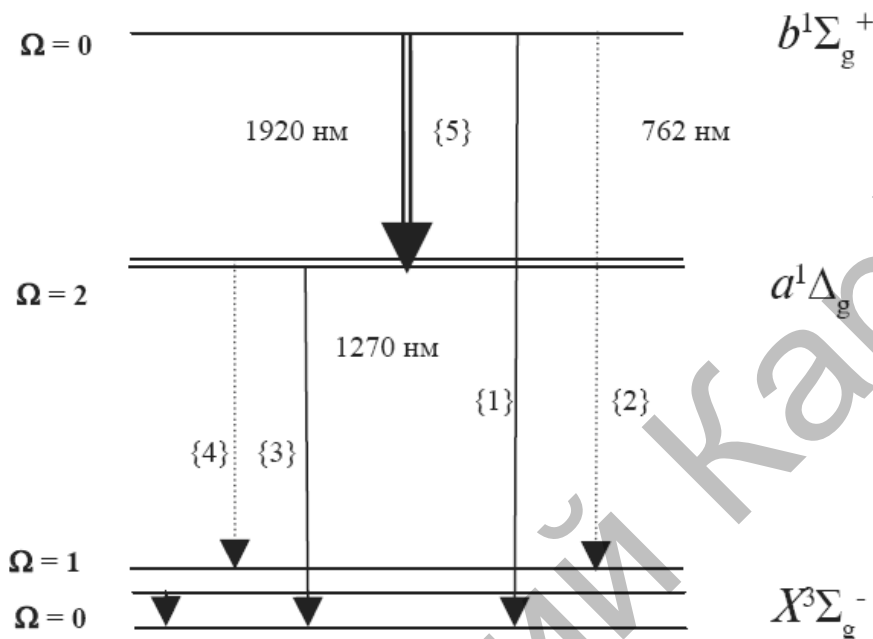

Fig. 1. The scheme of the excited states of O_2 molecules.

Most often, singlet oxygen is generated due to photoactivation (transitions {1}, {4}-{5} in Fig. 2), that is, the energy transfer from the excited state of the molecule sensitizer to O_2 ($^3\Sigma_g^-$). Many dyes that absorb light in the visible range may be used as a sensitizer, in particular the widespread natural substances, such as chlorophyll, protoporphyrin and other derivatives of porphyrin.

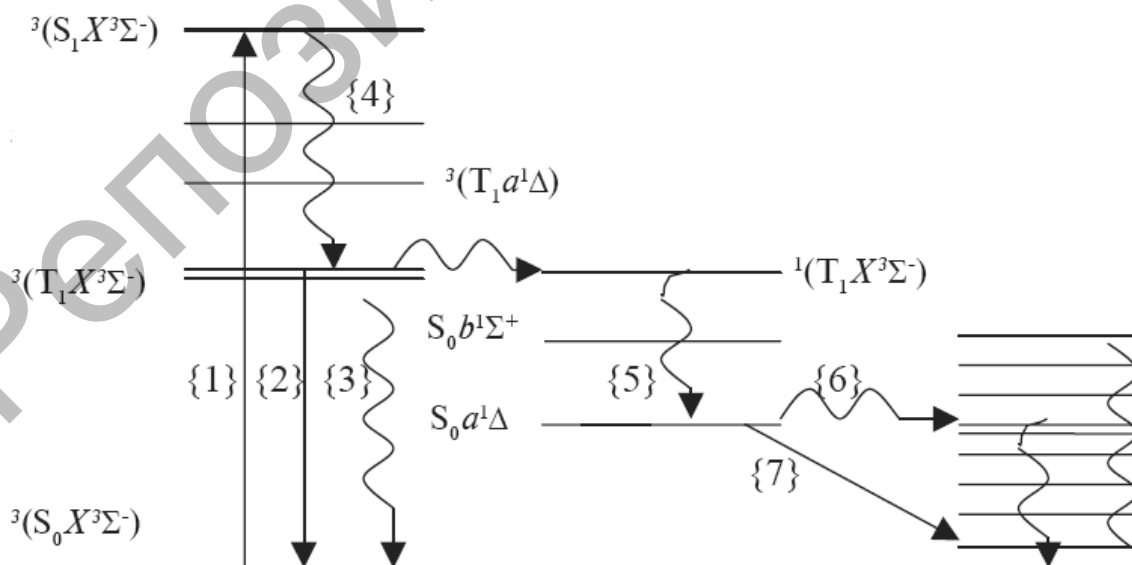

Fig.2. The scheme of the excited states of the molecule and the collision complex with the dye and the solvent of O_2

Singlet-excited state of the dye (S_1), resulted from the absorption of a photon (transition {1}, Fig. 2), usually in nonradioactive way rapidly transfers (transition {4}, Fig. 2) to a lower energy triplet-excited state (T_1), which is long-lived due to spin-forbiddance for a complete quenching (transition $T_1 \rightarrow S_0$ to the S_0 ground singlet state of the dye). Singlet state can disintegrate into products without spin-forbiddance (transition {5}, Fig. 2):



This energy transfer from the triplet excited dye to the singlet oxygen is very effective and limited by diffusion. The transition rate depends on exchange intermolecular interactions. Collisions not only activate 3O_2 for transformation into singlet oxygen (1O_2) due to the effect of light, but they also cause deactivation of 1O_2 (quenching, transitions {6}-{8} in Fig. 2).

Among the many optical effects an increased intensity of absorption at the $S_0 \rightarrow T_1$ transition of the dye, quenching its luminescence and a number of cooperative transitions can be distinguished. Owing to the collision of the excited dye molecule with O_2 (${}^3\Sigma_g^-$), a short-lived collision complex with the close to zero equilibrium constant is formed. In this case, as a result of mixing of the excited states of the complex and an electron-vibration relaxation, processes of the fluorescence quenching in the $S_1 \rightarrow S_0$ transition of the dye molecule can occur.

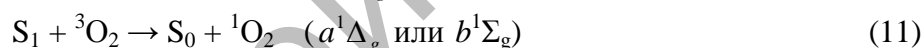
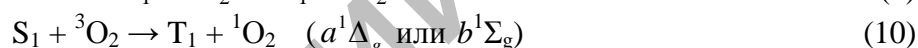

Here S_0 and S_1 are ground and excited singlet states of the dye molecule. Measuring of the output of the triplet states (T_1) of pyrene, anthracene and its perfluoro analogue molecules showed that the fluorescence quenching followed the reaction (9) and products of energy transfer were not observed [7].

Reaction (5) is spin-forbidden. The process of direct quenching $S_1 + {}^3O_2 \rightarrow T_1 + {}^3O_2$ does not depend on the specific intermolecular interaction associated with the paramagnetism of oxygen, since no change of the spin in particular molecules is required, it should not differ from quenching by ordinary diamagnetic molecules and therefore is ineffective.

All the interaction features between open shells of oxygen and solvent molecules are clearly reflected at the strengthening of radiation transitions. This accounts for many optical effects caused by the collision of oxygen molecules and the organic dye [8-9].

Thus, the interaction of an oxygen molecule and excited electronic states of complex organic molecules cause a number of interesting effects, the reason of which is not completely clear. This is particularly significant in nanostructures, when the size of the particle interaction area is comparable to the size of the reagents themselves.

REFERENCES

1. Zaleskaya G.A., Kuchinsky A.V. The role of complexes with the charge transfer at quenching of excited states of anthracene derivatives in the gas phase by oxygen // Journal of Applied Spectroscopy. - 2008.- P. 36-42.
2. Minaev B.F., Minaeva V.O., Shevchenko A.V. Oxidative stress and spin-catalysis at the processes of radiative and enzymatic activation of molecular oxygen // Chemical Sciences Series. - 2010. - P. 115-129.
3. Minaev B.F. Spin-catalysis at processes of photo- and bioactivation of molecular oxygen // Ukrainian Biochemical Journal. - 2009. - P. 21-43.
4. Minaev B.F. Electronic mechanisms of activation of molecular oxygen // Russian Chemical Reviews. 2007. - V.76, No. 11. - P. 1059-1083.

5. Muldahmetov Z.M., Minaev B.F., Ketsle G.A. Optical and magnetic properties of the triplet state. - Alma-Ata: Nauka, 1983. - 263 p.

6. Kobzev G.I. The dependence of the (f-X) and (b-a) transition moments at oxygen on the structure and the number of molecules in the medium and their mutual orientation // Proceedings of the VII Mendeleev Congress on General and Applied Chemistry. Kazan, - 2003. - V.1. - P. 140.

7. Kucherenko M.G., Gunkov V.V., Chmeryova T.M. The model of the electronic excitation energy transfer with molecular oxygen on the surface of a solid sorbent // Chemical Physics. - 2006. - V. 25, № 8. - P. 95-102.

8. Krasnovsky A.A. Singlet molecular oxygen and primary mechanisms of photodynamic effect of optical radiation. - Leningrad: Science, 1991. P. 64-134.

9. Kucherenko M.G., Gunkov V.V., Chmeryova T.M. Kinetics of oxygen-dependent photoreactions in a monomolecular layer by Langmuir-Blodgett films // Bulletin of OSU. - 2002. - P. 159-165.

Article accepted for publication 12.11.2012

Репозиторий КАРГУ