

Sh.S. Yarkimbaev¹, E.M. Fedorov¹, V.V. Redko², O.V. Galtseva^{3*}, X. Jiang⁴

¹National Research Tomsk Polytechnic University, Tomsk, Russia

²Scientific-Production Enterprise Redwill, Tomsk, Russia

³Tomsk State University of Control Systems and Radioelectronics, Tomsk, Russia

⁴Nanjing University of Science and Technology, Nanjing, China

(E-mail: rabota2013tpu@mail.ru)

Study of physical control methods for metric parameters of extended products in cable industry

The paper discusses the problems of electrical cables metric (geometric) parameters measurement. The methods of measuring the eccentricity of the electric cables (contact, ultrasonic, X-ray, and inductive-optical) are considered. The advantages and disadvantages of using these methods of technological control of cable products are shown. A study of the inductive-optical conversion method for measuring the eccentricity of a single-core cable, including the circuit for switching on the windings of the inductive converter, is proposed; the design of this converter is presented. The proposed solution makes it possible to achieve good conversion linearity when the conductor is displaced in the control zone. Wherein there is no need to use a system of mechanical drives for centering the magnetic transducer. In addition, the proposed scheme enables to combine the magnetic and optical transducer constructively in the same plane, which ensures to reduce its longitudinal dimensions relative to known analogues. The device prototype for eccentricity control is created based on the proposed transducer; its technical characteristics are confirmed. Direction of further research is determined as part of the development of the industrial design of the device.

Keywords: cable industry, contact methods, contactless methods, geometric characteristics, eccentricity, inductive method, cable core, linearity.

Introduction

Cables and wires are among vital products in modern everyday life. The cable industry is one of the leading and most rapidly developing sectors of the national economy. It has some features, such as a high manufacturability, energy intensity, resource intensity and a high degree of production automation. The maximum indicator of quality is achieved by improving the technology for control of the main product parameters during production and technological-process automation. Therefore, it is necessary to perform the in-process control of both electrical and geometric parameters of cable products [1–2].

The existing control systems (mainly foreign) of the diameter and eccentricity of the electric cable do not meet the requirements of modern Russian consumers in terms of price and number of operational characteristics. It is also unacceptable that there are virtually no instruments by domestic manufacturers of measuring equipment in a strategic area of cable manufacturing.

Controlling the damage of the conductor to the center of the insulating material in the manufacture of products for the cable industry is essential. Eccentricity is the most important parameter for a given type of product and technical and operational characteristics.

Continuous eccentricity control also reduces the consumption of expensive insulation materials (polyvinyl chloride, polyethylene, polyamide, etc.) in the production of signal and power wires and cables. The need

to measure the output of the extrusion die (core insulation temperature of ~ 130 °C) and the process continuity does not allow the use of contact and destructive eccentricity control methods. Figure 1 shows the section of the insulated core of the electrical cable, where the distance from the center of the conducting core to the center of the cable sheath (segment e) is its eccentricity, and the segments e_x and e_y are projections of eccentricity along the corresponding axes.

To perform the in-process control of insulation eccentricity, many types of devices are produced based on capacitive, inductive-optical, and X-ray measurement methods. Instruments manufactured by companies that are world leaders in the development and production of control devices for the cable industry, such as Sikora Industrieelektronik (Germany), Zumbach Electronic Automatic (Switzerland), ERMIS + (Russia) show the highest characteristics [3].

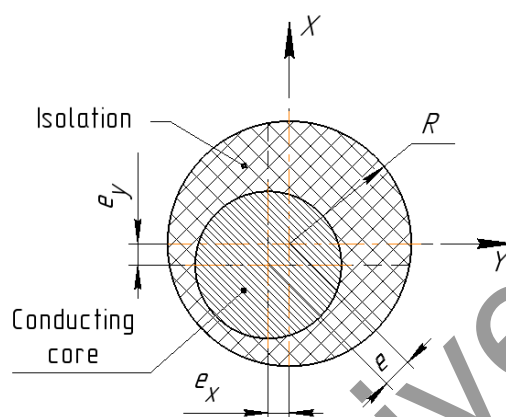

Figure 1. Section of the controlled insulated conductor of the electrical cable

Destructive and contact control methods

The essence of the destructive method of eccentricity control is the selection by the plant quality control service of samples of finished cable products and measurement of eccentricity on their section and, if required, other geometric parameters using measuring microscopes and other available tools that provide the necessary accuracy.

Destructive methods of controlling the eccentricity of cores and cables are not inherent methods of the in-process technological control. This measurement method refers to methods of output and quality control of the finished product or semi-finished product. The method allows rejection of the manufactured products by eccentricity, but it cannot be used to quickly intervene in the production process to eliminate the defect.

The results of these destructive diagnostic methods are distorted or inaccurate for a number of reasons. For example, as a result of deformation, geometric parameters of the structural parts of the product change during control, and control of an individual sample cannot guarantee the quality control of the entire cable coil, which can be several kilometers in length.

The output control of the eccentricity of the finished product alone is not enough to ensure its compliance with the required quality standards. Therefore, the in-process control of eccentricity is required using the developed methods and means of control, both contact and non-contact.

Eddy current methods

The operation principle is based on the use of eddy current resonance sensors that determine the distance to the surface of the conductor located in an insulated core. A pair of sensors is installed on opposite sides of the controlled core. Difference in signals of these sensors is proportional to deviation of the conductor center from the center of the measuring system, which is combined with the insulation center. As a result, the difference in sensor signals depends only on eccentricity along the measurement axis. To control eccentricity simultaneously in two directions perpendicular to each other, two pairs of sensors are installed so that sensitivity axes of each pair are located at an angle of 90° [4].

Alignment of the center of the measuring system with the center of insulation in different devices is implemented in two versions. The simplest version (Figure 2) suggests a mechanical contact method of centering with the help of two pairs of profiled rollers through which the controlled core passes. Sensors with wear-resistant coating that protects them from abrasion are pressed against the insulation surface of the moving core.

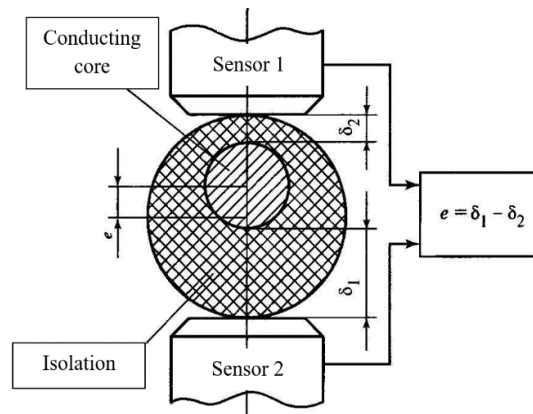

Figure 2. Eccentricity measurement principle with mechanical contact alignment method

This measuring system can be installed on the extrusion line only behind the cooling bath, where the applied insulation acquires the required rigidity. When using such a device, a high-quality drying of the core after cooling must be carried out, since moisture on the insulation surface impairs the accuracy of the device readings.

Non-contact methods

Contact methods used to control eccentricity have serious drawbacks described above. In particular, devices that employ contact methods cannot be installed behind the extruder since the material of the overlay cable sheath at this place is not fully solidified. Therefore, they cannot be used in the automatic extrusion control system. The measurement error of these systems does not meet modern requirements. In addition to contact and destructive methods, methods for non-contact control of cable eccentricity have been developed and implemented in the process.

Ultrasonic methods

Ultrasonic methods are used to control not only the outer diameter of the cable product but also the thickness of its insulation and eccentricity [5].

The method employs the ultrasonic principle (using echo pulse) illustrated in Figure 3. Piezoelectric transducer converts electric energy of short electric pulses into mechanical energy of acoustic waves. When propagating sound waves pass from one medium to another (for example, from water to a polymeric material), part of the energy of these waves is reflected towards the piezoelectric transducer. The waves are reflected from both the outer and inner surfaces of the coating.

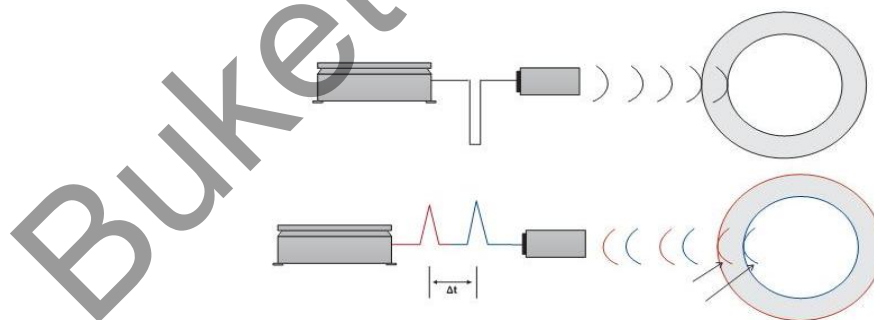

Figure 3. Use of echo pulse in measuring thickness of cable product coating

Thus, it is possible to measure the coating thickness, which will be equal to the production of the velocity of the acoustic wave propagation multiplied by the difference in time of the wave reflection from the outer and inner front surfaces of the coating Δt . The material thickness L can be calculated based on the value of the wave travel time and its velocity using the following ratio:

$$L = v\Delta t / 2, \quad (1)$$

where v is speed of the sound in the material of the measured product sheath, Δt is time of signal passage. The magnitude of the relative change in the signal amplitude can be used to detect defects or measure wave attenuation in the material.

When several pairs of ultrasonic transducers are used, eccentricity, diameter and thickness of the insulation of the product can be measured along two, three or more measuring axes, as shown in Figure 4.

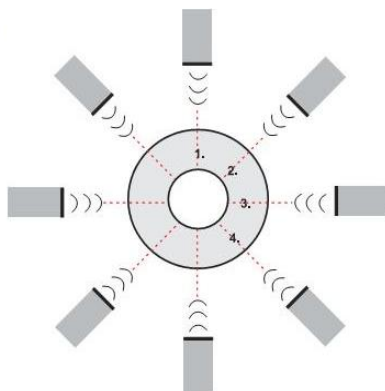

Figure 4. Four-coordinate measurement of cable eccentricity by ultrasonic method

As in the case of diameter measurement, ultrasonic methods of measuring eccentricity have the same disadvantages related to the emission character of primary transducers, which imposes a limitation on the use of such systems in cable enterprises [6–10].

Measurement of eccentricity by ionizing radiation

Due to the development of reliable X-ray sources, the emergence of high-resolution digital X-ray sensors, as well as the gigantic increase in computing power in recent years, new opportunities have opened up for the use of X-ray methods for measuring the internal structure of manufactured cable products, particularly computed tomography.

The main principle of tomography is to provide instrumental imaging of the insides of the object, typically not perceived by the human eye. This involves the use of a ray, which, unlike human vision, has an internal vision of the test object. Such properties are inherent to an X-ray beam, which is physically a high-energy electromagnetic wave formed on the anode of an X-ray source.

The X-ray beam is used to visualize the internal components of the test object. Absorption of some relative amount of X-ray energy is a typical property of a material, which is based on a simple empirical rule: the greater the atomic weight of the element, the higher the ability of the element to absorb beam energy. As a result, materials such as metals or alloys thereof have a high X-ray absorption coefficient, while low atomic weight elements such as polymers have a sufficiently low absorption coefficient depending on the type of polymer and additive material [11].

The X-RAY 2000 is specially made for the measurement of the wall thickness, eccentricity and the inner and outer diameter of single layer hoses and tubes as well as for single layer cables to measure the wall thickness, the concentricity and the outer diameter. Figure 5 shows an example device of this type (Sikora) [10].



Figure 5. X-RAY 2000, Sikora (X-ray meter)

When the beam passes through the test object, the beam energy is partially absorbed, and this depends on the distribution of the material inside the object. The resulting shadow images contain information about the test object. In the past, photographic plates were used to visualize information about an object obtained using a beam. Currently, high-resolution amorphous-silicon digital detectors are used to process digital image information obtained using a beam. The ordered digital data can be rendered by an image recording device or used for further calculations to control the internal geometry of the cable product.

The main advantage of X-ray measuring systems over others is that they can be used to control not only single-core cables and wires but also cable products of a complex multi-layer and multi-core structure.

The high cost of such systems (over 25 million rubles) makes them unprofitable and impractical for control of single-core cables of small cross-section, where cheaper measuring devices that employ other methods of measuring eccentricity can be applied. Another disadvantage is the use of X-rays, which pose a health hazard to the cable plant personnel [12–15].

Inductive-optical method of eccentricity measurement

Inductive transducers are now widely used for non-contact control of many parameters of products made of conductive materials. These transducers have a number of valuable qualities, the main of which are high sensitivity, simplicity of the device, small dimensions and weight, low inertia, etc. Inductive sensors allow appropriate selection of the supply current frequency to increase the sensitivity to a certain controlled value and reduce it in relation to other factors acting on the sensor. For example, by choosing the optimal conversion frequency of the inductive transducer, it is possible to reduce the effect on measurement results of the transverse offsets of the wire, as well as to offset from external electromagnetic interference [16–19].

Eccentricity is measured by using two transducers together on this method. The first is optical. The diameter and position of the cable sheath is measured here. Second, transformer converter is a definition electrically conductive core. Based on the joint data obtained, eccentricity is determined.

Figure 6 shows the design of the converter. The used magnetic converter is essentially a transformer. The functions of the exciting windings are performed directly by the conductor, and the inductive transducer is responsible for the functions of the measuring winding. To let the excitation current flow through the conductor, an inductor is used, which is a ring-shaped core in the form of a transformer. The primary winding is connected to the generator output, and the secondary winding is a conductor through which the core ring is passes.

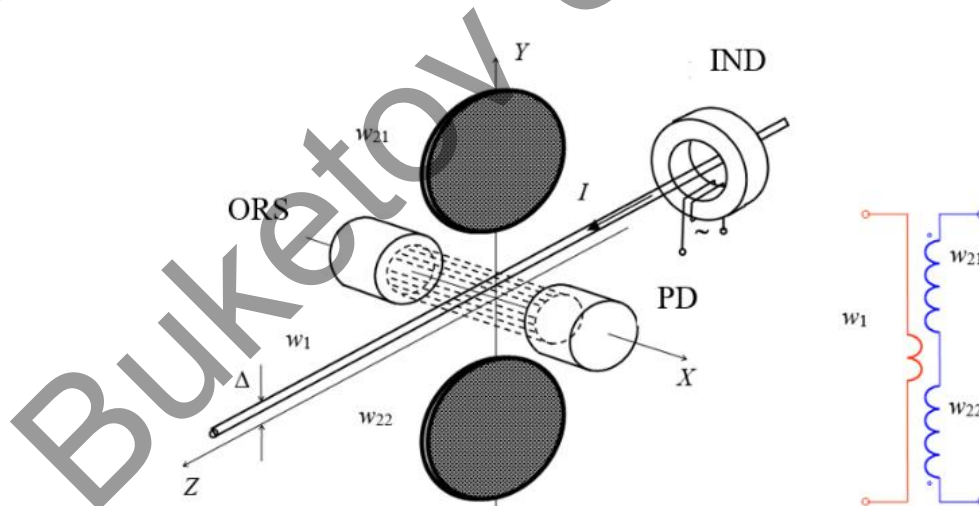

Figure 6. Design of the inductive-optical transducer: *ORS* — optical radiation source; *PD* — photodetector; *IND* — inductor; w_1 — conductor with current (excitation winding); w_{21} , w_{22} — measuring winding sections

The differential induction transducer has two identical sections w_{21} and w_{22} with windings located in the plane *ZOY*. The geometric axis of the induction transducer symmetry *OZ* coincides with its electric axis, which is characterized by a zero signal of the transducer, when the axis is aligned with the longitudinal axis of the conductor. When the conductor axis is displaced relative to the *OZ* axis in the *ZOY* plane, a signal is generated at the output of the induction transducer, which is functionally associated with the Δ offset value. Figure 6 shows only one induction transducer for measuring *OY* displacement. In fact, there is another simi-

lar transducer for measuring OX displacement, the windings of which are located in the orthogonal plane ZOX .

Experimental

An inductive-optical method for measuring the eccentricity and diameter of a single-core electric cable has been developed based on the above methods. The method implies a combined use of an optical method for measuring the displacement of the outer cable sheath in a diverging laser beam and an inductive transformer method for measuring the displacement of the cable conductor.

The proposed design includes a mutually inductive transducer with measuring windings that have four rectangular sections connected in series, which are designed to measure the conductor axis coordinates in one of the orthogonal planes. Each of the oppositely connected sections of the transducer described above is replaced by a pair, according to the sections connected (Figure 7). The optimal ratio of the transducer geometric parameters can provide high linearity of the conversion function and the signal independence in the winding designed for measuring the displacement along one axis on the displacement along the orthogonal axis in a wide range of displacements measured.

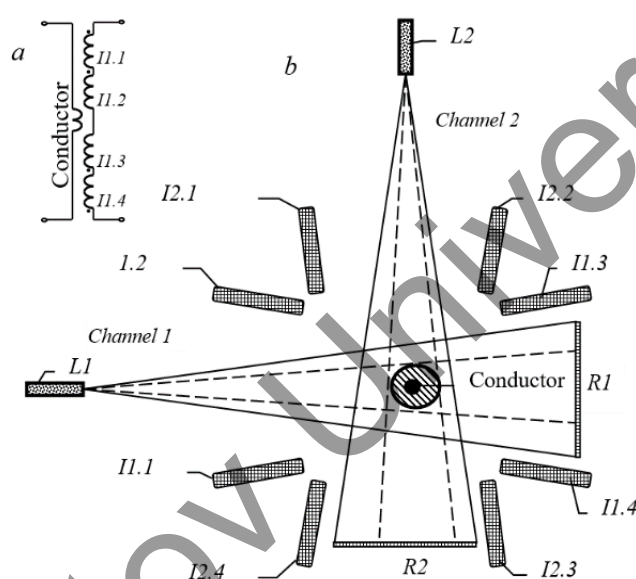

Figure 7. Inductive-optical transducer: *a* — winding connection circuit of the magnetic transducer of one channels; *b* — transducer design

Figure 7 shows a cross-section of the combined inductive-optical transducer with a plane perpendicular to the measured cable, where $11.1-11.4$ and $12.1-12.4$ are windings of the inductive transducer, which measures the cable core displacement in the first and second channels; $L1$, $P1$ and $L2$, $P2$ are the semiconductor laser module and the multi-element receiver of both measuring channels of the optical measuring system, which controls the position of the outer cable sheath.

Figure 7 shows the design of an inductive measuring transducer, which differs in its windings located in planes intersecting at an angle of 60° and passing through the longitudinal axis of symmetry of the transducer. Similar to the transducer presented in Figure 6, the controlled conductor performs the function of the excitation winding. Each of the pair of measuring windings designed for measuring the conductor axis coordinates along one of the orthogonal axes has two sections connected in series.

Solid lines indicate the dependences of the coordinate factor $K(x,y)$ on the change in the measured y coordinate and on the change in the x coordinate, when the conductor is displaced in the orthogonal direction for the proposed transducer with an optimal ratio of the geometric parameters x_l and y_l in Figure 8. The dotted lines indicate similar dependencies for the prototype transducer.

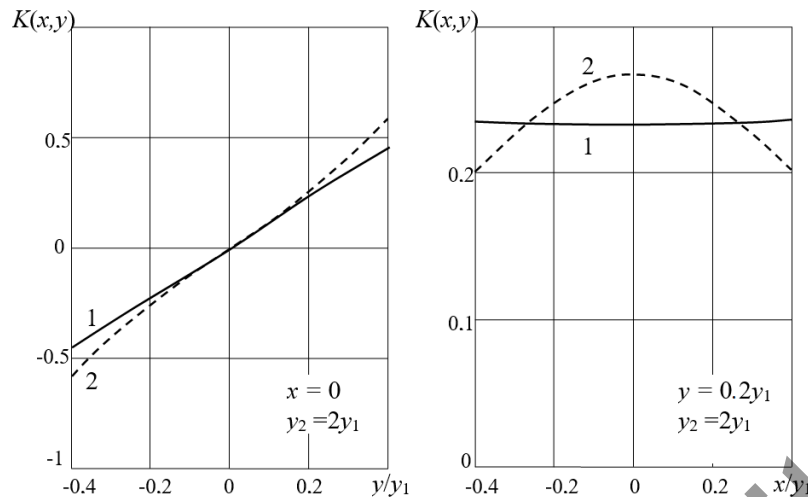

Figure 8. Dependence of the coordinate factor $K(x,y)$ on the change in the measured coordinate of the conductor axis $y(a)$ and on the change in the orthogonal coordinate $x(b)$ for the proposed transducer (1) and the prototype transducer (2)

Figure 9 shows a graph of the coordinate factor dependence, at which the winding section is set at an angle of 60° .

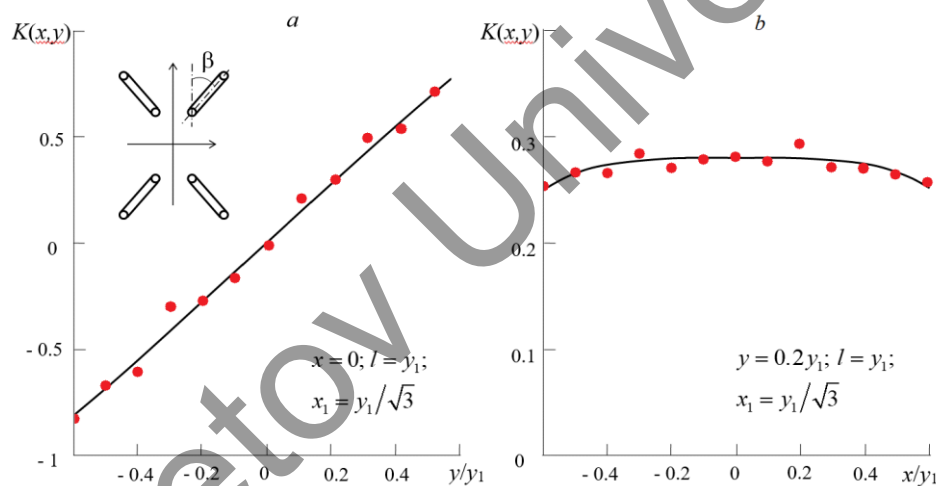

Figure 9. Theoretical and practical dependence of $K(x,y)$ on the measurement of the coordinate of the axis of the conductor $y(a)$ and on the change in the coordinate $x(b)$

During the experimental part, samples of wire of various diameters were taken. Measurements were carried out by displacing it from the center of the axis of the indicator and optical unit. The results are shown in Table 1.

Table 1

Experimental results

D, [mm]	Cx0, [mm]	Cy0, [mm]	Cx, [mm]	Cy, [mm]	Ux, [mV]	Uy, [mV]
1	2	3	4	5	6	
0.2	0	0	-0.003	0.001	-0.3	0.1
	1	1	0.997	1.006	99.7	100.6
	1	-1	0.999	-1.002	99.9	-100.2
	-1	-1	-0.998	-1.002	-99.8	-100.2
	-1	1	-1.003	1	-100.3	100
0.5	0	0	0	0.002	0.0	0.2
	1	1	0.998	0.999	99.8	99.9
	1	-1	1.001	-1	100.1	-100

1	2	3	4	5	6	
	-1	-1	-0.999	-0.999	-99.9	-99.9
	-1	1	-1.002	0.997	-100.2	99.7
1	0	0	-0.002	-0.004	-0.2	-0.4
	1	1	1.001	0.998	100.1	99.8
	1	-1	0.998	-0.997	99.8	-99.7
	-1	-1	-1	-1.003	-100.0	-100.3
	-1	1	-1.002	0.998	-100.2	99.8
1.2	0	0	0	-0.003	0.0	-0.3
	1	1	0.995	0.997	99.5	99.7
	1	-1	1	-1	100.0	-100
	-1	-1	-0.997	-0.999	-99.7	-99.9
	-1	1	-1	1.002	-100.0	100.2
1.5	0	0	0.002	-0.001	0.2	-0.1
	1	1	0.999	1	99.9	100
	1	-1	1.001	-0.998	100.1	-99.8
	-1	-1	-1.002	-1.002	-100.2	-100.2
	-1	1	-1.001	0.998	-100.1	99.8

An experiment was carried out to compare the conversion function of the proposed converter. As we can see on the graph, the values obtained experimentally characterize good linearity and an order of magnitude less dependence on the conductor displacement in the orthogonal direction.

The discrepancy between the results of mathematical and physical modeling is within the total error of the measuring instruments used in the experiments.

Results and Discussion

Transducer new design with fundamental differences from the existing foreign measuring instruments is proposed (Figure 9). Owing to the magnetic transformer mutually inductive converter, the conversion function has significant linearity, which eliminates the need for electric drives that center the measuring unit in automatic mode relative to the measurement object. Also, it becomes possible to conveniently arrange inductive and optical sensors into a single split system due to the more convenient orthogonal arrangement.

Conclusions

An inductive-optical method for measuring the eccentricity and diameter of a single-core electric cable has been proposed based on the combined use of the optical method for measuring the displacement of the outer cable sheath in a diverging laser beam and the inductive transformer method for measuring the displacement of the conducting core. The proposed inductive method, in contrast to analogs, has a linear transformation function due to the features of the implementation of the measuring transducer. This study is underway. Further, a technical implementation is planned to determine the numerical difference between the used method and the proposed one.

Acknowledgments

This research was supported by TPU development program.

References

- 1 Lu, M., Tsai, J., Shen, S., Lin, M., & Hu, Y. (2020). Estimating sustainable development performance in the electrical wire and cable industry: Applying the integrated fuzzy MADM approach. *Journal of Cleaner Production*, 277, 122440.
- 2 Yermoshin, N.I., Yakimov, E.V., & Goldshtein, A.E. (2020). Double-channel resistance-to-voltage converter for cable teraohmmeters. *Bulletin of the university of Karaganda-Physics*, 1(97), 105–114.
- 3 Jafaripour, M., Sadrameli, SM, Mousavi, SAHS, & Soleimanpour, S. (2021). Experimental investigation for the thermal management of a coaxial electrical cable system using a form-stable low temperature phase change material. *Journal of Energy Storage*, 44(B), 103450.
- 4 Jamali-Abnavi, A., Hashemi-Dezaki, H., Ahmadi, A., Mahdavianesh, E., & Tavakoli, M.-J. (2021). Harmonic-based thermal analysis of electric arc furnace's power cables considering even current harmonics, forced convection, operational scheduling, and environmental conditions. *International Journal of Thermal Sciences*, 170, 107135.

- 5 Rongen, R.T.H. van Ijzerloo, & Cotofana, C. (2011). Cratering response method to study the effect of ultrasonic energy on Cu-wire bonding quality. *Microelectronics Reliability*, 51, 1865–1868.
- 6 Yucel, M., Legg, M., Kappatos, V., & Gan, T. (2017). An ultrasonic guided wave approach for the inspection of overhead transmission line cables. *Applied Acoustics*, 122, 23–34.
- 7 Yi, J.-J., Peng, X.-M., Wang, B., Wang, Z.-Y., & Jing, G.-Q. (2019). Ultrasonic Inspection Technique for Axial Forces of Bolts in Cable Clamps of Suspension Bridge. *Bridge Construction*, 49, 68–73.
- 8 Shrisha, M.R., Chakraborty, N., Mahapatra, D.R., & Sunkara S. (2018). FPGA based Ultrasonic thickness measuring device. *International Conference on Advances in Computing, Communications and Informatics (ICACCI)*, 779–784.
- 9 Saravanan, J.T. (2021). Guided ultrasonic wave-based investigation on the transient response in an axisymmetric viscoelastic cylindrical waveguide. *Ultrasonics*, 117, 34364203.
- 10 Mostafavi, S., & Markert, B. (2020). Ultrasonic weld strength and weld microstructure characteristics in multi-strand aluminum cables (EN AW-1370) — Effect of process parameters. *Journal of Manufacturing Processes*, 57(1), 893–904.
- 11 Mühlheim, B. (2017). Zumbach has developed innovative on-line measurement, monitoring and control equipment since 1957. *MPT Metallurgical Plant and Technology International*, 44–49.
- 12 Galos, J., Ghaffari, B., Hetrick, E., Jones, M., Benoit, M., Wood, T. Sanders, P., Easton, M., & Mouritz, A. (2021). Novel non-destructive technique for detecting the weld fusion zone using a filler wire of high x-ray contrast. *NDT & E International*, 124, 102537.
- 13 Zhang, J., Huang, E., Liu, S., Zeng, Z., Feng, Ch., & Xie, Y. (2020). X-ray image processing method for buffer layer defect in high voltage cable. *Journal of Physics: Conference Series*, 1792, 012046.
- 14 Guoqing, M., Pengfei, L., Zilong, C., Yubing, D., Hao, Z., & Xiaoli, H. (2020). High-voltage cable fault analysis base on X-ray image processing. *Journal of Physics: Conference Series*, 1627, 012006.
- 15 Liu, S., Zhang, L., Duan, J., Zhang, J., Huang, F., Duan, X.-I.I., & Zeng, Z. (2020). X-ray digital image advanced processing and buffer layer defect intelligent identification of power cable. *Journal of Physics: Conference Series*, 1601, 052028.
- 16 Li Y., Qin B., & Bo, H. (2021). Research on eccentricity performance of winding wire capacitance rod position measurement sensor. *Annals of Nuclear Energy*, 161, 108403.
- 17 Popovic, L. (2019). Inductive influence of HV cable lines in urban and suburban areas. *Electric Power Systems Research*. Vol. 120.
- 18 ГОСТ 31996–2012. Кабели силовые с пластмассовой изоляцией на номинальное напряжение 0,66; 1 и 3 кВ. Общие технические условия. — М.: Стандартинформ Российской Федерации, 2013. — 34 с.
- 19 Fedorov, E., Chicherina, N., Tlusty, J., & Tuzikova V. (2019). Diffraction control methods of extended products' diameter. *Materials Science Forum*, 942, 97–109.

Ш.С. Яркимбаев, Е.М. Федоров, В.В. Редько, О.В. Гальцева, Цзян Ксю

Кабель өнеркәсібінің ұзартылған бұйымдарының метрикалық параметрлерінің физикалық бақылау әдістерін зерттеу

Мақалада электр кабельдерінің метрикалық (геометриялық) параметрлерін өлшеу мәселелері, сонымен қатар, электр кабельдерінің эксцентриситеттерін өлшеу әдістері (контакттілі, ультрадыбыстық, рентгендік және индуктивті-оптикалық) қарастырылған. Кабельдік бұйымдарды технологиялық бақылаудың осы әдістерін қолданудың артықшылықтары мен кемшіліктері көрсетілген. Индуктивті түрлендіргіштің орамдарын қосу тізбегін қоса алғанда, бір ядролы кабельдің эксцентриситетін өлшеудің индуктивті-оптикалық түрлендіру әдісін зерттеу және осы түрлендіргіштің конструкциясы ұсынылған. Ұсынылған шешім өткізгіштің басқару аймағында орын ауыстырған кезде жақсы конверсиялық сызықтылыққа қол жеткізуге мүмкіндік береді. Бұл жағдайда магниттік түрлендіргішті орталықтандыру үшін механикалық жетектер жүйесін пайдаланудың қажеті жоқ. Сондай-ақ ұсынылған схема магниттік және оптикалық түрлендіргішті бір жазықтықта конструктивті түрде біріктіруге мүмкіндік береді, бұл белгілі аналогтарға қатысты оның бойлық өлшемдерін азайтуға мүмкіндік жасайды. Ұсынылған түрлендіргіш негізінде эксцентристик бақылауға арналған құрылғының түпүлгісі жасалды; оның техникалық сипаттамалары расталды. Әрі қарайғы зерттеулердің бағыты құрылғының өнеркәсіптік үлгісін әзірлеу бөлігі ретінде анықталды.

Кілт сөздер: кабель өнеркәсібі, контакттілі әдістер, контактсыз әдістер, геометриялық сипаттамалар, эксцентристик, индуктивті әдіс, кабель тарамы, сызықтық.

Ш.С. Яркимбаев, Е.М. Федоров, В.В. Редько, О.В. Гальцева, Цзян Ксю

Исследование методов физического контроля метрических параметров протяженных изделий кабельной промышленности

В статье рассмотрены вопросы измерения метрических (геометрических) параметров электрических кабелей, а также методы измерения эксцентриситета электрических кабелей (контактный, ультразвуковой, рентгеновский и индуктивно-оптический). Показаны преимущества и недостатки использования данных методов технологического контроля кабельной продукции. Предложено исследование индуктивно-оптического преобразовательного метода измерения эксцентриситета одножильного кабеля, включающего схему включения обмоток индуктивного преобразователя; представлена конструкция этого преобразователя. Предлагаемое решение позволяет добиться хорошей линейности преобразования при перемещении проводника в зоне контроля. При этом нет необходимости использовать систему механических приводов для центрирования магнитного преобразователя. Кроме того, предложенная схема позволяет конструктивно совместить магнитный и оптический преобразователи в одной плоскости, что позволяет уменьшить его продольные размеры по сравнению с известными аналогами. На основе предложенного преобразователя создан прототип устройства контроля эксцентриситета; его технические характеристики были подтверждены. Направление дальнейших исследований определено в рамках разработки промышленного образца устройства.

Ключевые слова: кабельная промышленность, контактные методы, бесконтактные методы, геометрические характеристики, эксцентриситет, индуктивный метод, жила кабеля, линейность.

References

- 1 Lu, M., Tsai, J., Shen, S., Lin, M., & Hu, Y. (2020). Estimating sustainable development performance in the electrical wire and cable industry: Applying the integrated fuzzy MADM approach. *Journal of Cleaner Production*, 277, 122440.
- 2 Yermoshin, N.I., Yakimov, E.V., & Goldshtein, A.E. (2020). Double-channel resistance-to-voltage converter for cable teraohmmeters. *Bulletin of the university of Karaganda-Physics*, 1(97), 105–114.
- 3 Jafaripour, M., Sadrameli, SM, Mousavi, SAHS, & Soleimanpour, S. (2021). Experimental investigation for the thermal management of a coaxial electrical cable system using a form-stable low temperature phase change material. *Journal of Energy Storage*, 44(B), 103450.
- 4 Jamali-Abnavi, A., Hashemi-Dezaki, H., Ahmadi, A., Mahdaviymanesh, E., & Tavakoli, M.-J. (2021). Harmonic-based thermal analysis of electric arc furnace's power cables considering even current harmonics, forced convection, operational scheduling, and environmental conditions. *International Journal of Thermal Sciences*, 170, 107135.
- 5 Rongen, R.T.H. van Ijzerloo, & Cotofana, C. (2011). Cratering response method to study the effect of ultrasonic energy on Cu-wire bonding quality. *Microelectronics Reliability*, 51, 1865–1868.
- 6 Yucel, M., Legg, M., Kappatos, V., & Gan, T. (2017). An ultrasonic guided wave approach for the inspection of overhead transmission line cables. *Applied Acoustics*, 122, 23–34.
- 7 Yi, J.-J., Peng, X.-M., Wang, B., Wang, Z.-Y., & Jing, G.-Q. (2019). Ultrasonic Inspection Technique for Axial Forces of Bolts in Cable Clamps of Suspension Bridge. *Bridge Construction*, 49, 68–73.
- 8 Shrishya, M.R., Chakraborty, N., Mahapatra, D.R., & Sunkara S. (2018). FPGA based Ultrasonic thickness measuring device. *International Conference on Advances in Computing, Communications and Informatics (ICACCI)*, 779–784.
- 9 Saravanan, J.T. (2021). Guided ultrasonic wave-based investigation on the transient response in an axisymmetric viscoelastic cylindrical waveguide. *Ultrasonics*, 117, 34364203.
- 10 Mostafavi, S., & Markert, B. (2020). Ultrasonic weld strength and weld microstructure characteristics in multi-strand aluminum cables (EN AW-1370) — Effect of process parameters. *Journal of Manufacturing Processes*, 57(1), 893–904.
- 11 Mühlheim, B. (2017). Zumbach has developed innovative on-line measurement, monitoring and control equipment since 1957. *MPT Metallurgical Plant and Technology International*, 44–49.
- 12 Galos, J., Ghaffari, B., Hetrick, E., Jones, M., Benoit, M., Wood, T. Sanders, P., Easton, M., & Mouritz, A. (2021). Novel non-destructive technique for detecting the weld fusion zone using a filler wire of high x-ray contrast. *NDT & E International*, 124, 102537.
- 13 Zhang, J., Huang, E., Liu, S., Zeng, Z., Feng, Ch. & Xie, Y. (2020). X-ray image processing method for buffer layer defect in high voltage cable. *Journal of Physics: Conference Series*, 1792, 012046.
- 14 Guoqing, M., Pengfei, L., Zilong, C., Yubing, D., Hao, Z., & Xiaoli, H. (2020). High-voltage cable fault analysis base on X-ray image processing. *Journal of Physics: Conference Series*, 1627, 012006.
- 15 Liu, S., Zhang, L., Duan, J., Zhang, J., Huang, F., Duan, X.-I.I., & Zeng, Z. (2020). X-ray digital image advanced processing and buffer layer defect intelligent identification of power cable. *Journal of Physics: Conference Series*, 1601, 052028.
- 16 Li Y., Qin B., & Bo, H. (2021). Research on eccentricity performance of winding wire capacitance rod position measurement sensor. *Annals of Nuclear Energy*, 161, 108403.
- 17 Popovic, L. (2019). Inductive influence of HV cable lines in urban and suburban areas. *Electric Power Systems Research*. Vol. 120.

18 GOST 31996–2012. (2013). *Kabeli silovye s plastmassovoi izolyatsiei na nominalnoe napriazhenie 0,66; 1 i 3 kV. Obshchie tekhnicheskie usloviia [Power cables with plastic insulation for rated voltages of 0,66; 1 and 3 kV. General specifications]*. Moscow: Standartinform Rossiiskoi Federatsii [in Russian].

19 Fedorov, E., Chicherina, N., Tlusty, J., & Tuzikova V. (2019). Diffraction control methods of extended products' diameter. *Materials Science Forum*, 942, 97–109.

Букетов University