

UDC 004.942

DEVELOPMENT OF IMITATING MODEL OF SKIP MOTION IN THE PROGRAM ENVIRONMENT ANSYS MAXWELL

A.A. Aikeyeva¹, X.S. Rogovaya¹, A.R. Tanskozhanova¹, P.A. Mukhtarova², A.E. Ospanov³.

¹The Karaganda State University named after the academician E.A. Buketov, Kazakhstan
aikeeva@mail.ru

²The Asia Pacific University Innovation and Technology, Kuala Lumpur, Malaysia

³The Karaganda State Technical University, Kazakhstan

This work is directed on development of imitating model of electromagnetic lifting installation system elements. In the work the principle of work of electromagnetic lifting installation elements of the "skip-constant magnet coil" is presented and described. Model operation was carried out in the ANSYS Maxwell program. The task of model operation is determination of the key magnetic parameters of installation elements: the Lorentz forces, magnetic intensity and magnetic induction. According to calculated parameters graphic charts are made and engineering functions in the form of the equations with one variable are constructed.

Keywords: electromagnetic lifting installation, magnetic levitation, ANSYS Maxwell program, The Lorentz force, magnetic intensity, magnetic induction.

Introduction

The imitating modeling of dynamic processes of interaction of electromagnetic lifting installation basic elements pursues the purpose to determine optimum and rational parameters of system without expensive experiments in the calculated path. Possibilities of the modern computers and packages of applied programs allow to realize rather completely the system approach to the description of multifactorial dynamic conditions of integrally interdependent links of uniform dynamic system "skip-constant magnet-coil" [1, 2].

During the research the model of skip motion in mine shaft of was developed. This model is based on the effect of magnetic levitation. The essence of the method is concluded in the fact there are permanent magnets located on the skip or under the skip, and on all height of mine shaft it is offered to arrange coil windings. In this case the skip with permanent magnets moves in a shaft through the coil according to figure 1. When passing permanent magnets through the coil there is magnetic field which allows the skip to develop speed, thereby moving it upwards.

1. The method of calculation

These researches were confirmed with natural experiment. During work the imitating model in the ANSYS Maxwell program where the skip is set in motion by forces of interaction of magnetic field of the coil in a shaft and permanent magnet on the skip was investigated. Advantage of system is concluded in the way that is potentially new. Activation of permanent magnets does not require energy. Until recently researchers considered that permanent magnets do not possess force, sufficient for levitation. However, this problem can be solved by placement of magnets to the massif. Thus magnets have to be located in such a way that the magnetic field arises between the massif and the coil, and are capable to support levitation at very low speed – about 5 km/h. However, the cost of such massifs from permanent magnets is very high that is shortcoming [3,4].

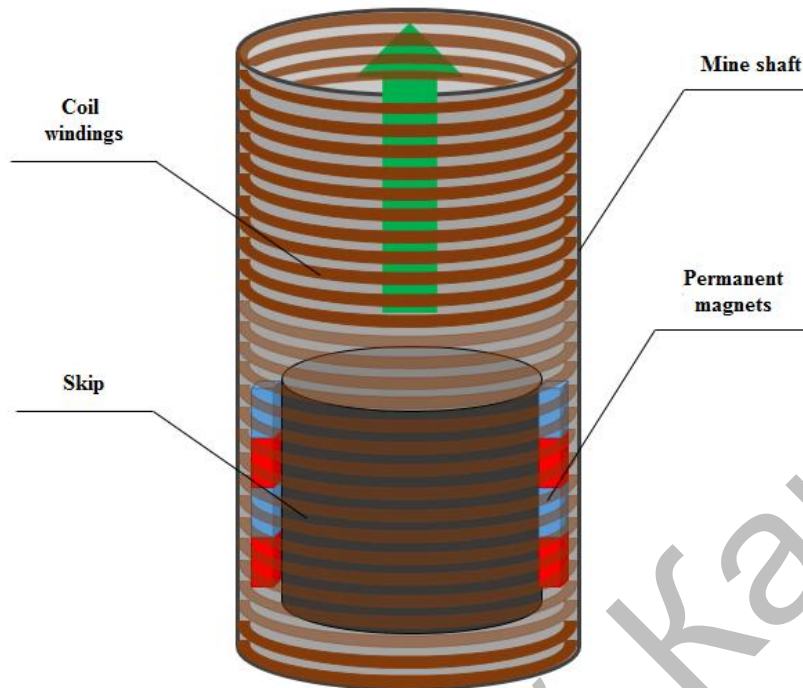

Fig.1. Model of skip motion in the shaft of mine

When developing the model of this research the properties of materials are set from library of the ANSYS Maxwell program. For permanent magnet NdFeB element (neodymium – iron - wood) was chosen as material. It is the class of the rare-earth magnets made by pressing or molding of intermetallid $\text{Nd}_2\text{Fe}_{14}\text{B}$.

Advantages of this class of magnets are high magnetic properties (B , H and $(B-H)$ max), and also low cost. Because of weak incorrodibility they are usually covered with copper, nickel or zinc. In our case magnets have to be covered with nickel. For windings of the coil copper was chosen as material. Besides the sizes of skip and coil were chosen [5, 6, 7].

2. Results and discussion

During research the necessary key parameters were defined, vector B indexes of magnetic induction, intensity of magnetic field H and the Lorentz force J . The first characteristics specify key parameters of magnetic field. The Lorentz force is directed on the axis z , according to placement of the coil in a mine shaft.

Figure 2 presents the stage of the model solution in which the characteristic of Lorentz force is defined. To complete the picture interactions the moment of finding the skip at 2.5 second of motion and in the middle of the shaft of mine is presented, that is on the fourth second of motion. On the color chart on the left the characteristic values from the most minimum at interaction allocated in the blue color, to the most maximal, allocated in the red color are indicated..

By results of experiment in the ANSYS Maxwell program the schedule (fig. 3) which presents the dependence of the maximal values of the Lorentz force characteristic on time was made. For more detailed graphic report the time interval makes 0.5 seconds. Each size of Lorentz force on the graphics is the result of addition of massif magnetic field from permanent magnets and the coil. In each separate instant the sum of these sizes is various. Thus, the change of values of the Lorentz force is explained in graphics.

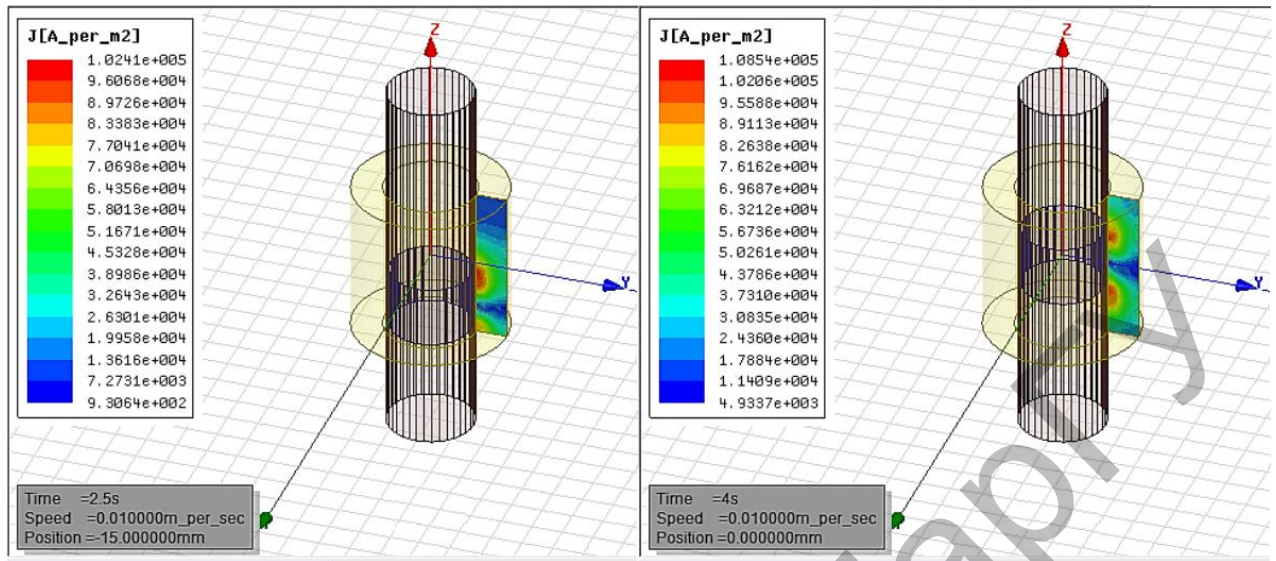

a) at 2,5 second of skip motion; b) at the 4th second of skip motion

Fig.2. Results of calculation of the Lorentz force of the model

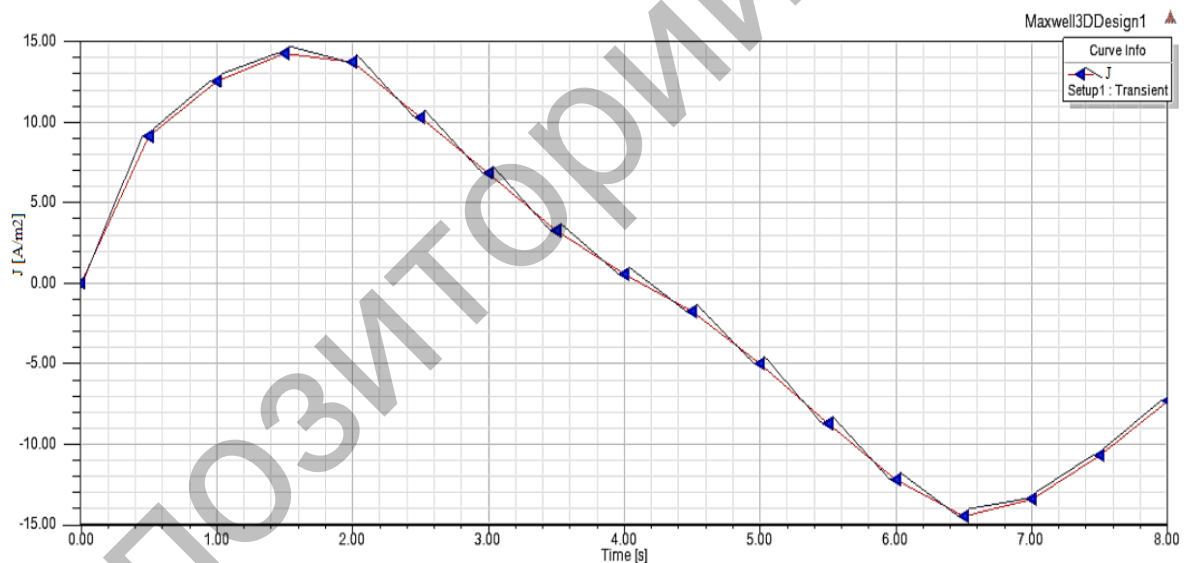
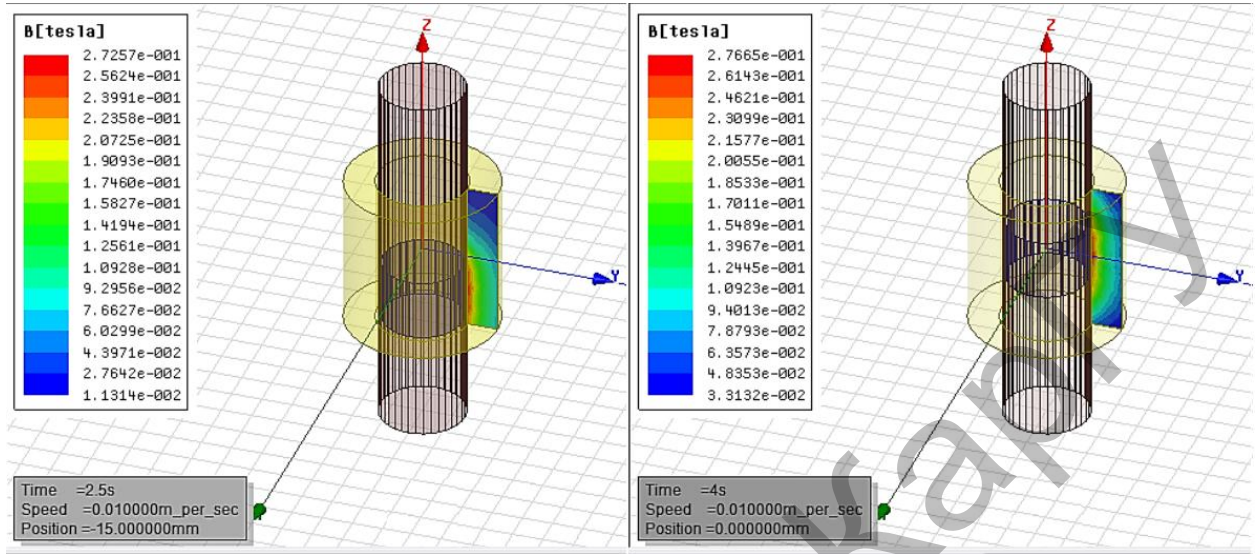

Fig.3. Dependence of change of the Lorentz force of J on time

Figure 4 presents the stage of the model solution in which the characteristic of magnetic field induction is defined. To complete the picture interactions the moment of finding the skip at 2.5 second of motion and in the middle of the shaft of mine is presented, that is on the fourth second of motion. On the color chart on the left the characteristic values from the most minimum at interaction allocated in the blue color, to the most maximal, allocated in the red color are indicated..

By results of experiment in the ANSYS Maxwell program the schedule (fig. 5) which presents the dependence of the maximal values of the magnetic field induction characteristic on time was made. For more detailed graphic report the time interval makes 0.5 seconds. Each size of magnetic field induction on the graphics is the result of addition of massif magnetic field from permanent

magnets and the coil. In each separate instant the sum of these sizes is various. Thus, the change of values of the magnetic field induction is explained in graphics.



a) at 2,5 second of skip motion; b) at the 4th second of skip motion
 Fig. 4. Calculation results of magnetic induction of B model

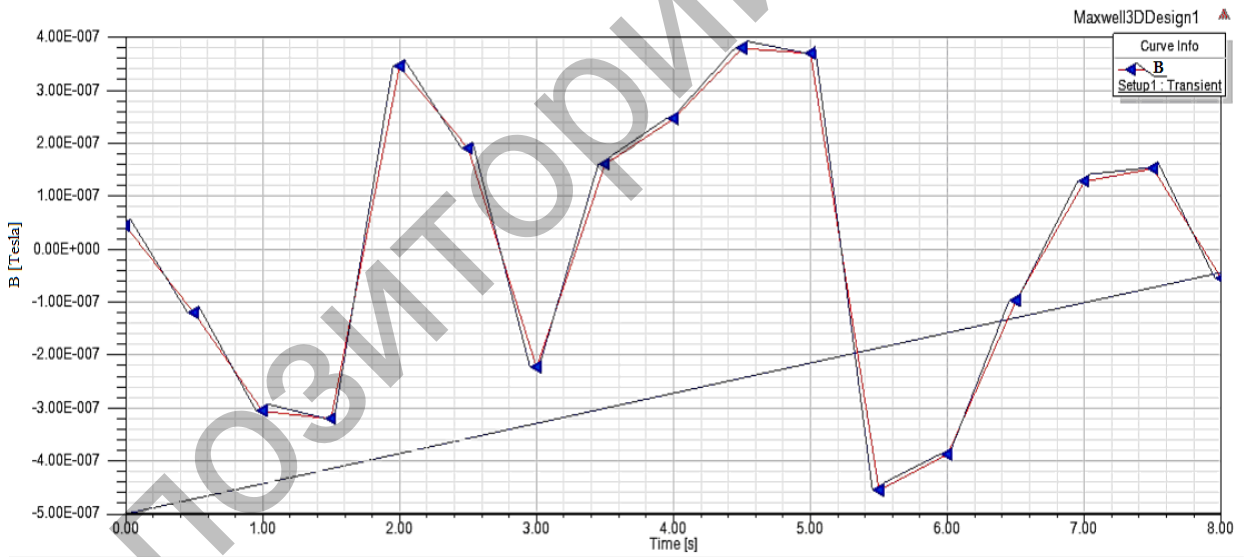
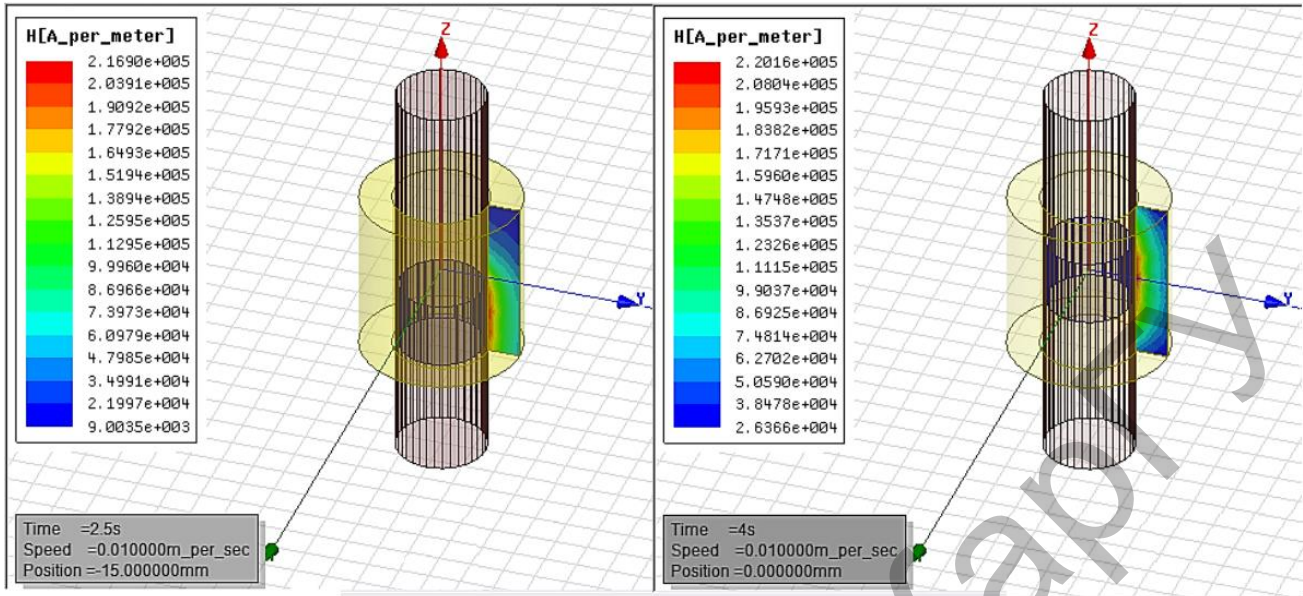

Fig.5. Change Dependence of magnetic induction B on time

The similar picture occurs when calculation of parameters of magnetic field intensity. In figure 6 there is the stage of the model solution in which parameter H is defined. The model in the figure is presented at the stage of the fourth second. On the color chart on the left the values of the magnetic intensity characteristic from the most minimum up to the most maximal value are given.



a) at 2,5 second of skip motion; b) at the 4th second of skip motion

Fig. 6. Calculation results of magnetic field intensity of the model

By the results of experiment in the ANSYS Maxwell program the schedule (fig. 7) on which dependence of the maximal values of the magnetic intensity characteristic on time was made. The time interval of experiment makes 0.5 seconds. Each value of magnetic intensity on the schedule is the result of addition of magnetic field of the constant massif and the coil. In each separate instant the sum of these values is different. In this way the change of values of magnetic intensity is explained in the schedule.

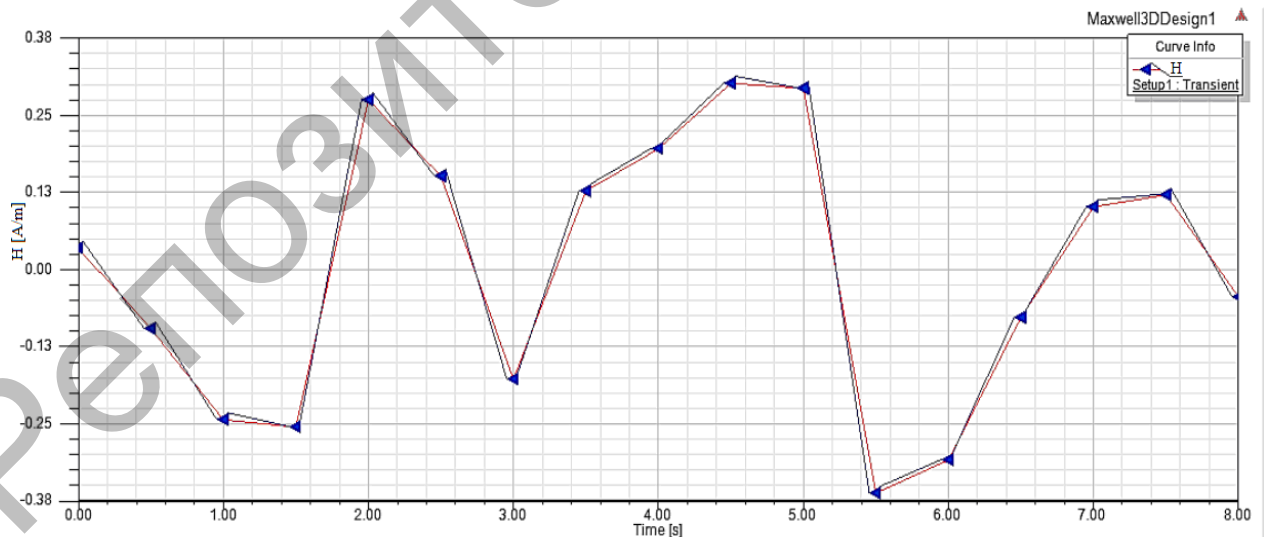

Fig.7. The schedule of dependence of intensity of H magnetic fields on time

Conclusion

On the basis of the conducted researches the following new scientific results:

- Developed a simulation model in the software environment of ANSYS Maxwell.
- Developed algorithms and software modules in the software package ANSYS Maxwell to determine the electromagnetic force interaction of the array of permanent magnets on the skip and the winding of coil in the shaft.
- When processing the results of the research was obtained non-linear objective functions of the basic magnetic characteristics H , B and J . The equations were written on every second of the experiments. In the research, we changed the radius of a skip, the internal radius of the coil and the external radius of the coil. Objective functions were written regarding this. These functions can be used in the creation of electromagnetic lifting installations.

Acknowledgments

The work was supported by the Grant financing of Ministry of Education of the RK, the priority "Power and mechanical engineering", №0686/GF4, "Development of the system of automatic control and complex protection of energy saving electromagnetic lifting installation".

REFERENCES

- 1 Aikeyeva A.A. Imitation modeling of dynamics of densing devices in mine pneumo lifting installations. *Proceeding of the science-technical conference «Strategiczne pytania światowej nauki – 2008»*. Przemśl: Wydawca Nauka I studia, 2008, Vol. 9, pp. 30 - 34.
- 2 Kazakov Yu.B., Shchelykalov Yu.Ya. Research of magnetic field in the air gap of starter of CT230Б. *Theses of reports of the science-technical conference*, Ivanovo, 2008, pp. 129 - 131.
- 3 Chigarev A.V., Kravchuk A.S., Smalyuk A.F. *ANSYS for engineers: Instr.manual*. Moscow, Mashinostroenie, 2004, 512 p. (in Russia)
- 4 Aikeyeva A.A., Zhautikov B. A., Rogovaya K.S., Zhautikov F.B., Mukhtarova P. A. Application of computer model operation for the choice of parameters of electromagnet. *Automatic equipment and informatics*. Karaganda, KarSTU, 2015, No. 2(37), pp. 71 - 74
- 5 Aikeyeva A.A., Zhautikov B. A., Rogovaya X.S., Zhautikov F.B, Mukhtarova P.A. 3-D modeling of elements of skip-electromagnet system. *Eurasian Physical Technical Journal*. Karaganda, 2015, No. 2(24), pp. 28 - 32.
- 6 Aikeyeva A.A., Zhautikov B. A., Zhanasbayeva A.S., Mukhtarova P. A. Research of loads on the skip of mine and career electromagnetic lifting installation. *Bulletin of the Karaganda State University*, Karaganda, 2015, No. 3(79), pp. 90 - 95.
- 7 Aikeyeva A.A., Zhautikov B. A., Zhautikov F.B., Mukhtarova P. A. The research loads on the skip of mine and quarry electromagnetic lifting installation. *Eurasian Physical Technical Journal*. Karaganda, 2015, No.1 (23), pp. 59 - 64.