



Received: 04/04/2024  
Original Research Article

Revised: 29/06/2024

Accepted: 17/09/2024

Published online: 30/09/2024



Open Access under the CC BY -NC-ND 4.0 license

UDC 536.7

## THERMAL TECHNOLOGICAL CONDITION OF IVG.1M RESEARCH REACTOR CORE UNDER VARIOUS OPERATING MODES

Skakov M.K.<sup>1</sup>, Martynenko Ye.A.<sup>\*2,3</sup>, Yerdybayeva N.K.<sup>3</sup>, Akayev A.S.<sup>2</sup>,  
Bekmuldin M.K.<sup>2</sup>, Prozorova I.V.<sup>2</sup>

<sup>1</sup>National Nuclear Center of the Republic of Kazakhstan, Kurchatov, Kazakhstan

<sup>2</sup>Institute of Atomic Energy Branch of RSE NNC RK, Kurchatov, Kazakhstan,

<sup>3</sup>D.Serikbayev East Kazakhstan Technical University, Ust-Kamenogorsk, Kazakhstan

\*Corresponding author: [Kirichek@nnc.kz](mailto:Kirichek@nnc.kz)

**Abstract.** The relevance of the study is related to the determination of the thermal characteristics of the IVG.1M research reactor core with the low enriched uranium fuel under the nominal and design operating modes. The thermal technological condition of the IVG.1M research reactor during the start-up are determined by the readings of the temperature, pressure and coolant flow sensors of the information and measuring system. The indirect methods including the computer simulating ones are used to determine the temperature of the core structural materials and the distribution of the coolant temperature by the height of the fuel assembly. The research has been carried out using the method of the finite element analysis using the ANSYS Fluent software package. The study goal was to verify the adequacy of the calculation methodology and obtain the calculated data on the temperature distribution in the fuel assembly in the reactor power range from the nominal to design one. The article presents a description of the IVG.1M reactor, the research methodology, computer model, simulation results and the comparison of the calculated data with the experimental ones. The study scientific novelty consists in determining the temperature conditions of the fuel rods during the reactor operation at various levels of the design capacity with a conservative approach to the cooling conditions. The significance of the research results lies in the fact that a computer model can be used to determine the characteristics of the IVG.1M reactor core under the reactor various operating modes and to analyze the thermohydraulic processes in the fuel assembly.

**Keywords:** IVG.1M RR, fuel rod, temperature field, computer simulation, fuel assembly, thermophysical calculation.

### 1. Introduction

The IVG.1M research reactor (RR) is a heterogeneous thermal neutron nuclear reactor with a light-water coolant. It is possible to conduct the scientific research on the safety of the peaceful atomic energy use at the reactor, including: studying on the radiation material science, testing the structural materials of the nuclear technology, practicing the operating modes of the fuel assemblies (FA), studying the emergency situations. In 2023 the reactor core was transferred from the highly enriched uranium fuel (HEU) to the low enriched uranium fuel (LEU) in order to reduce the risks of the proliferation of the fissile materials [1]. During the conversion, the neutronics and thermal characteristics of the reactor were improved, which was confirmed in a series of the power starts-up. To date, scientific research has been resumed.

The IVG.1M research reactor core is a set of water-cooled technological channels (WCTC) with the fuel assemblies (FA). The maximum design capacity of the reactor core consisting of 30 WCTC is estimated at 60 MW, while at the moment the research starts-up are carried out at a capacity of no more than 10 MW. The limitations on the realized capacity are related to the configuration of the cooling system, which has restrictions

on the coolant specified flow rate. The reactor cooling system upgrading is a relevant task and requires the comprehensive study.

Throughout the entire life cycle of the IVG.1M research reactor the engineering and technical staff collects, processes, systematizes and analyzes the operational information. The calculation and methodological base created on the basis of many-year experience, which is a complex of methods, procedures and software, allows ensuring the safe operation and research at the reactor. New computational and experimental techniques are being developed on an ongoing basis to control the parameters of the nuclear reactor and conduct the research at a high technological level. The reactor is equipped with the information and measurement system, which records, displays and archives the sensor readings during the start-up. The reactor thermal parameters are recorded with a frequency of 10 Hz by the resistance thermometers, pressure, level and flow sensors [2]. The coolant parameters are recorded at the inlet and outlet to the reactor core, therefore, the determination of the temperature distribution of the water and structural materials in the core is carried out by the indirect methods, including the computer simulation. The computer simulating methods have also been successfully applied to analyze the safety of conducting the reactor experiments at the IVG.1M reactor [3], determining the core neutronics and thermophysical characteristics [4-7], analyzing the hydraulic and thermophysical processes in the reactor FA [8-10]. When simulating the neutronics and thermohydraulic processes of the reactor core, each model had its drawbacks and assumptions.

The goal of the study presented in the article was to verify the adequacy of the chosen calculation method and obtain the calculated data on the temperature distribution in the fuel assembly of the IVG.1M research reactor when it operates at nominal and design levels of the realized power. The research was carried out using the method of the finite element analysis using a three-dimensional computer simulation. The advantage of the computer simulation used for the study, compared with previously used ones [8-10], is the fact that the twisted structure of the fuel rod was taken into account when developing the model. The scientific novelty of the research consists in determining by calculation the temperature modes of the fuel rods operation in the range of the reactor design power from 10 to 60 MW with a conservative approach to the cooling conditions.

## 2. Materials and methods

The IVG.1M RR core is equipped with a set of 30 WCTCs, which are located radially along three circles with the different radii. There are 12 WCTC with the FA height of 800 mm in the first and second rows, along the diameter of the radius 126 and 163.5 mm. There are 18 WCTCs with a 600 mm height of the fuel part in the third row along a circumference with a radius of 239 mm. The reflector surrounding the core is made of beryllium. Ten control drums (CD) with absorbing elements control the reactor and protect it. Each CD is equipped with a stepper motor that allows turning the drum from 0° to 180°. There is an experimental channel designed for the installation of the irradiated devices in the core central part. The experimental channel is surrounded by 12 beryllium reactivity compensation rods. Figure 1 shows the reactor diagram [5].

The fuel part of each of the 30 WCTC contains 468 fuel rods in a tight package. Twelve fillers with a diameter of 1.6 mm, 24 fillers with a diameter of 2.2 mm and an axial insert with a diameter of 7.4 mm are used to distance the fuel rods in the fuel assemblies. The fillers and the axial insert are made of E110 alloy. The fuel rods are in the form of spiral rods made using innovative technology [11]. The fuel rod is a metallurgically bonded cladding and core. The fuel core of the fuel rod is a matrix made of E110 alloy with strands of metallic uranium located along the axis. The number of uranium strands is 133, the diameter of the strand is ~40 μm. The fuel rod cladding is made of E110 zirconium alloy.

Figure 2 shows the diagram of the fuel element with the dimensions [8]. The reactor is cooled using a single-circuit coolant pumping pattern from a storage tank with a volume of 1,500 m<sup>3</sup>. Three 4MSK-10 pumps are used to provide the sufficient coolant flow during the power start-up. The core is cooled as follows. The water is supplied through four paths to cool the reactor cover, the loop channel, the side reflector and the interchannel space in the reactor nominal operation mode. In the inter-channel space, the coolant moves upwards, cooling the outer surfaces of the walls. In the collection chamber under the reactor cover, the water is collected from the cover cooling paths, the side reflector and the interchannel space and enters the WCTC for cooling the FA, after which it is drained into a storage tank.

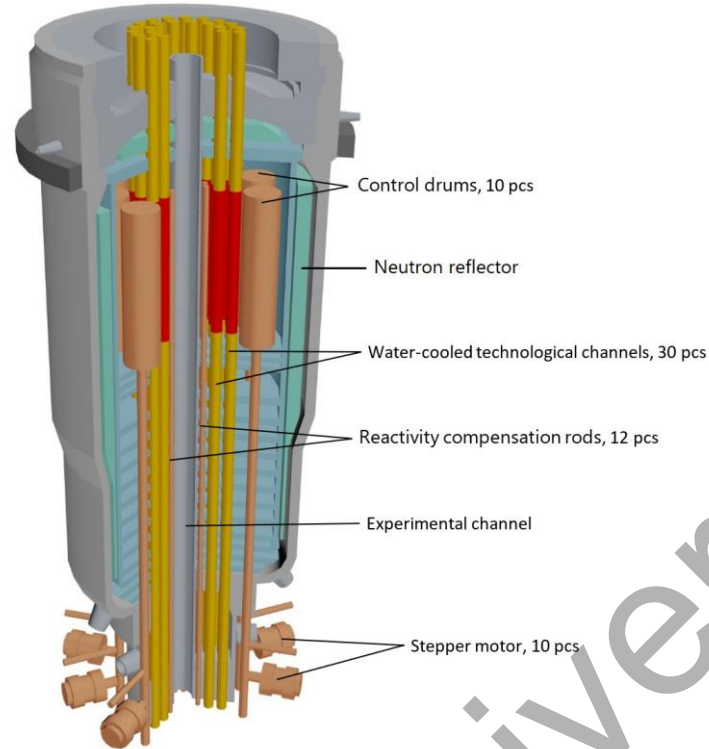

**Fig.1.** IVG.1M reactor diagram.

A three-dimensional model of the IVG.1M reactor FA was constructed in the ANSYS Fluent release 2021R2 software package to conduct the study [12]. The ANSYS Fluent is a universal software analysis system that implements the finite element method (FEM), which allows solving the stationary and non-stationary physical problems, including the simulation of the liquid and gas flows, heat transfer and heat exchange processes [13].

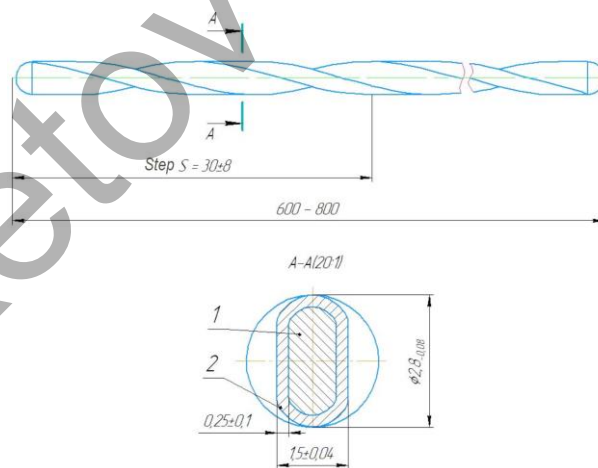

**Fig.2.** Fuel rod diagram: 1-core, 2-cladding.

Solving the problem using the numerical methods in the ANSYS Fluent software package includes the implementation of the basic sequential actions:

- defining the geometry of a computational model;
- splitting the model into a finite number of simple elements;
- setting the material properties required for the calculation;
- setting the initial and boundary conditions of the problem;
- selecting and configuring the solver, performing the calculation;
- analyzing and interpreting the results, performing additional calculations if necessary.

Figure 3 shows the computer simulation used to conduct the study with a superimposed finite element grid. The geometry of the computational model was chosen in the following way. The computational model is the FA elementary cell. The fuel rod fully corresponds to the actual geometric dimensions, taking into account the twist step of 30 mm. The model height corresponds to the height of the fuel part of the WCTC of 1<sup>st</sup> and 2<sup>nd</sup> rows in the and is 800 mm. During the construction of the model, it was assumed that the cross-sectional area for the coolant in the model is 1/468 of the cross-sectional area for the coolant in the WCTC since the fuel assembly contains 468 fuel rods.

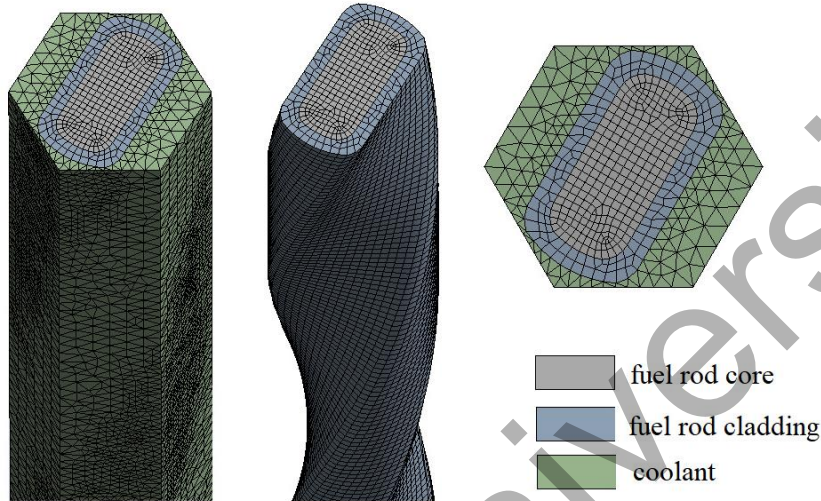

Fig.3. Calculation model of the IVG.1M reactor FA.

The flow section area for the coolant in the WCTC was determined by the formula (1):

$$S = 0.25 \cdot \pi \cdot d_0^2 - 468 \cdot S_{tv} - 0.25 \cdot \pi (n_1 \cdot d_1^2 + n_2 \cdot d_2^2 + d_c^2) \quad (1)$$

where:

$d_0$  is inner diameter of the FA shell,  $d_0=66.4$  mm;

$S_{tv}$  is cross-sectional area of the fuel rod, according to the technical documentation,  $S_{tv}=3.967$  mm<sup>2</sup>;

$n_1$  is number of type 1 fillers,  $n_1 = 12$ ;

$n_2$  is number of type 2 fillers,  $n_2 = 24$ ;

$d_1$  is diameter of type 1 fillers,  $d_1 = 1.6$  mm;

$d_2$  is diameter of type 2 fillers,  $d_2 = 2.2$  mm;

$d_c$  is diameter of the axial insert,  $d_c = 7.4$  mm.

The boundary conditions set for obtaining the temperature distribution in the FA model are given below:

- the symmetry condition is set on the side faces of the computational model;
- the coolant flow is determined by the conditions of mass flow inlet into the path and the outflow;
- the initial pressure in the path is assumed to be 1 MPa;
- the energy release profiling by the FA height is set using a text file.

The calculations have been carried out using the average values for the WCTC of 1<sup>st</sup> and 2<sup>nd</sup> rows, since the greatest energy release occurs in these channels, and consequently, the coolant and fuel rods reach the highest temperature values. The obtained data on the energy release as a result of the neutronics calculations are used to conduct the study. The energy release for the calculation is set with the assumption that all fuel rods in the assembly have the same energy release. Figure 4 show the relative energy release profile for the FAs of the WCTC of 1<sup>st</sup> and 2<sup>nd</sup> rows per 1 MW of the reactor power [14]. During the calculation, the thermophysical properties of the materials of the computer model [15, 16] are set depending on the temperature in the form of a piecewise linear function, while the properties of the fuel rod core are homogenized.

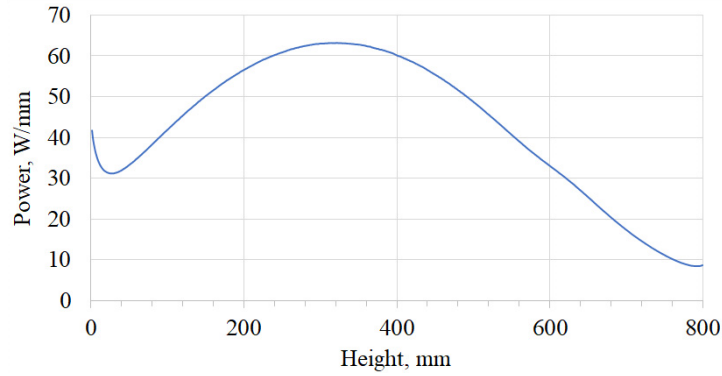

**Fig.4.** Profile of relative energy release of the WCTC of 1<sup>st</sup> and 2<sup>nd</sup> rows.

A  $k-\epsilon$  Realizable flow model has been chosen to simulate the coolant turbulent flow. The finite element grid of the model consists of 3,353,802 units and 7,503,831 elements, the solution convergence is achieved by an iterative process. The temperature at the WCTC outlet is also determined by the energy balance equation [17] for substantiating the correctness of the calculation model and the selected solver settings (2):

$$\int_0^{800} Q = G \cdot Cp \cdot (T_{out} - T_{in}) \quad (2)$$

where:

- $Q$  – distribution of the energy release in the fuel rod by the assembly height, W;
- $G$  – coolant flow, kg/s;
- $Cp$  – water heat capacity at an average temperature in the path, J/(kg × °C);
- $T_{out}, T_{in}$  – coolant temperature at the FA outlet and inlet, respectively, °C.

### 3. Results and discussion

As a result of the study, the temperature field distributions for the stationary reactor operation modes have been obtained. The information on the technological parameters of the IVG.1M reactor, obtained from the results of power starts-up, was used as initial data for the thermophysical calculations. The problem boundary conditions were determined in accordance with the water temperature values at the core inlet and the water flow through the WCTC. The energy release by the FA height was set according to the reactor thermal power realized in the experiments. Table 1 shows the experimental values of the water flow through the WCTC, the water temperature at the WCTC inlet and outlet for 10 levels of the stationary reactor power.

**Table 1.** Comparison of the experimental data with calculated ones.

Parameter	Reactor power level <sup>1</sup> , MW					
	1.00	1.97	2.91	6.07	9.08	10.21
Water flow for the WCTC of 1 <sup>st</sup> and 2 <sup>nd</sup> rows <sup>1</sup> , kg/s	2.08	2.08	2.13	2.14	2.13	2.11
Water temperature at the WCTC inlet <sup>1</sup> , °C	24.8	17.4	22.9	26.2	29.6	28.2
Water temperature at the WCTC outlet <sup>1</sup> , °C	28.9	25.1	34.3	49.5	64.0	67.3
Water temperature at the FA outlet <sup>2</sup> , °C	28.7	25.2	33.9	49.3	64.4	67.7
Water temperature at the FA outlet <sup>3</sup> , °C	28.7	25.2	34.1	49.3	64.3	67.6
Maximum temperature of the outer surface of the fuel rod cladding <sup>2</sup> , °C	29.3	26.3	35.6	52.8	69.6	73.5
Maximum temperature of the fuel core <sup>2</sup> , °C	29.6	26.9	36.5	54.7	72.5	76.8

<sup>1</sup>experimental values; <sup>2</sup>calculated values by computer modeling; <sup>3</sup>calculated values by the energy balance equation.

The table also shows the water temperature values at the WCTC outlet obtained by computer modeling and the values of the maximum calculated temperatures of the fuel core and the fuel rod surface for the given stationary power levels. For the comparison, the table shows the values of the calculated temperature at the FA outlet, calculated using the energy balance formula (2).

According to the analysis of the data given in Table 1, the value of the standard deviation of the experimental and calculated (according to the energy balance formula) water temperature at the FA outlet is  $\sim 0.31$ . The value of the standard deviation of the experimental and calculated (by the computer modeling method) water temperature at the FA outlet is  $\sim 0.23$ . Good consistency of the calculated results with experimental data allows estimating the adequacy of the calculated model and the chosen calculation method.

Figure 5 shows, as an example, the volumetric distribution of the temperature field obtained as a result of the calculation with the reactor thermal power at a stationary level of 10.21 MW. Figure 6 shows the temperature field and the velocity vector field of the model cross-section (10.21 MW) at the height with the maximum energy release (0.309 m).

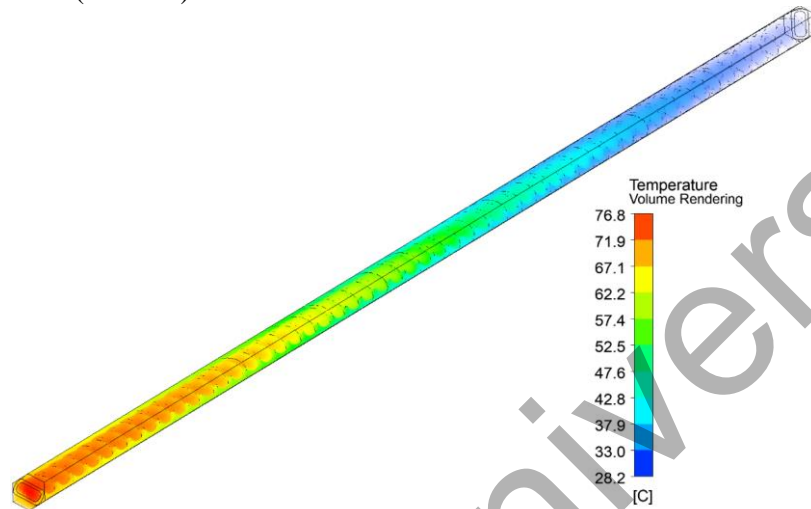

Fig.5. Volumetric distribution of the temperature field of the model.

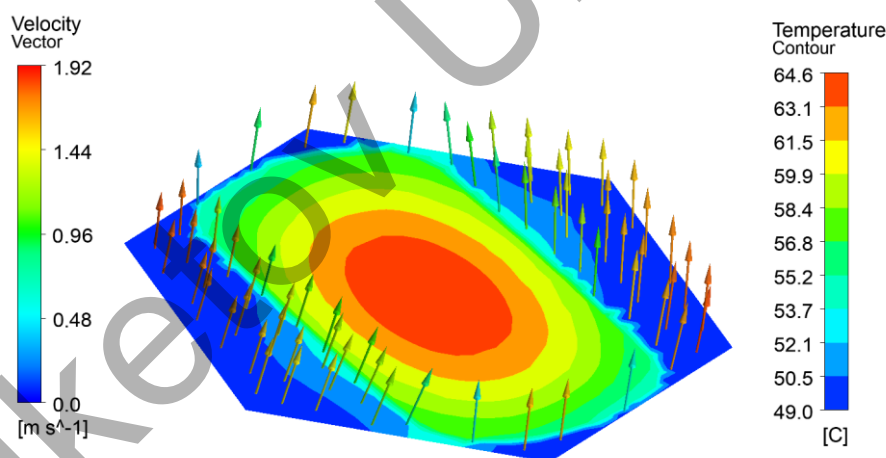

Fig.6. Temperature field of the FA model cross-section.

The operational documentation of a WCTC with low enriched fuel contains the information on the limits of the permissible values of the thermal technical parameters during the operation, however, the cooling modes of the core for ensuring the safe operation at a power level from 10 to 60 MW are not regulated. At present, the restrictions on the realized capacity of the IVG.1M research reactor are associated with the complete set of the cooling system, which can provide a water flow rate of no more than 2.5 kg/s, while the limit of the WCTC normal operation for a set flow rate is 12 kg/s.

A series of calculations has been carried out to assess the temperature modes of the fuel rods during the reactor operation at a design capacity of 10 to 60 MW. When setting the boundary conditions, the conservative cooling conditions were chosen. The water temperature at the FA inlet was assumed to be 55 °C, which is the limit value of the WCTC normal operation. The water flow for cooling was chosen according to the energy

balance equation (2) in such a way that the water temperature at the FA outlet was of maximum permissible value of the WCTC normal operation, equal to 95 °C.

Figure 7 shows the dependence of the calculated values of the water temperature at the FA outlet, the maximum temperatures of the fuel core and the fuel rod cladding at the reactor operating power at the level from 10 to 60 MW at the specified coolant flow rates through the WCTC.

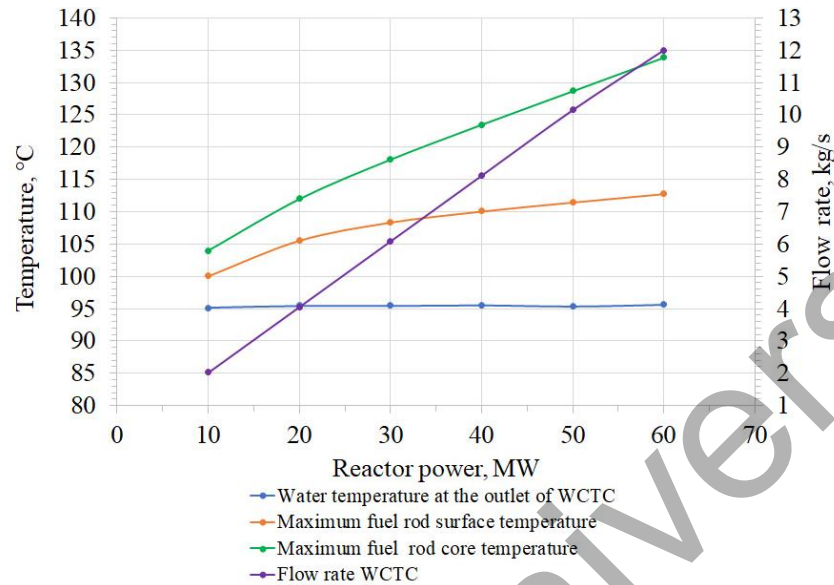

**Fig.7.** Dependence of the fuel rod temperature on the reactor operation power at a set water flow rate.

As Figure 7 shows, the maximum calculated temperature of the fuel core under the specified cooling conditions does not exceed the limit of the WCTC normal operation equal to 146 °C. The temperature limit of the WCTC normal operation for the surface of the fuel rod is 110 °C. The maximum calculated surface temperature of the fuel rod slightly (2 °C) exceeds the limit value of the WCTC normal operation only if the reactor is operating at a power level of 60 MW and the WCTC water rate is 12 kg/s.

To analyze the calculated results, it is necessary to take into account that the emergency protection settings of the reactor are set by the personnel according to the appropriate start-up program for each experiment and under the standard conditions of conducting the experiments at a power level of up to 10 MW for the coolant temperature values and are 50 °C at the reactor inlet and 95 °C at the outlet.

#### 4. Conclusions

As a result of the computational studies using the three-dimensional computer model of the FA of the IVG.1M reactor, the temperature distribution of fuel rods and coolant has been determined under the stationary reactor operating modes at various power levels from 1 to 10 MW. The good consistency of the calculated results with experimental data has confirmed the adequacy of the calculation model and the chosen calculation method.

In a series of the calculations, the temperature modes of the operation of the fuel rods have been determined in the range of the design capacity from 10 to 60 MW with the minimum values of the coolant flow, providing the coolant temperature within the values of the WCTC normal operation. The calculation results show that under the set cooling conditions, the temperature modes of the operation of the fuel rods correspond to the values of the WCTC normal operation.

The computer model can be used for determining the characteristics of the IVG.1M reactor core under various operating modes, as well as for analyzing the thermohydraulic processes in the FA. The disadvantage of the model is that the model geometry does not allow determining the radial temperature distribution of the fuel rods in the FA, and also does not take into account the heat transfer from the WCTC outer surface into the coolant.

**Conflict of interest statement**

The authors declare that they have no conflict of interest in relation to this research, whether financial, personal, authorship or otherwise, that could affect the research and its results presented in this paper.

**CRedit author statement**

Skakov, M.K.: Supervision, Project administration; Martynenko, Ye.A.: Writing-Original Draft, Investigation, Methodology; Yerdybayeva N.K.: Writing-Review and Editing; Akayev A.S.: Conceptualization; Bekmuldin M.K.: Data Curation, Visualization; Prozorova I.V.: Resources. The final manuscript was read and approved by all authors.

**Funding**

This work was funded by the Ministry of Science and Higher Education of the Republic of Kazakhstan (Program-Target Financing Project BR21882185 "Research in Support of the Creation and Safe Operation of a Nuclear Power Plant in the Republic of Kazakhstan").

**References**

- 1 Sabitova R., Popov Y., Irkimbekov R., Prozorova I., Derbyshev I., Nurzhanov E., Surayev A., Gnyrya V., Azimkhanov A. (2023) Results of Experiments under the Physical Start-Up Program of the IVG.1M Reactor. *Energies*, 16, 6263. DOI: 10.3390/en16176263.
- 2 Korovikov A.G., Ilynych S.A., Yermakov V.A., Serikbayev B.S. (2018) Third phase of information and measuring system modernization of IVG.1M research reactor. *NNC RK Bulletin*, 3, 33 – 39. DOI:10.52676/1729-7885-2018-3-33-39. [in Russian]
- 3 Surayev A.S., Irkimbekov R.A., Ponkratov Yu.V. (2020) Calculation of the thermal state of the experimental device for tests in the IVG.1M reactor. *NNC RK Bulletin*, 2, 144 – 153. Available at: [https://journals.nnc.kz/jour/article/view/253?locale=en\\_US](https://journals.nnc.kz/jour/article/view/253?locale=en_US) [in Russian]
- 4 Sabitova R.R., Prozorova I.V., Irkimbekov R.A., Popov Yu.A., Bedenko S.V., Prozorov A.A., Mukhamediyev A.K. (2022) Methods to Study Power Density Distribution in the IVG.1M Research Reactor After Conversion. *Applied Radiation and Isotopes*, 185, 110259. DOI:10.1016/j.apradiso.2022.110259.
- 5 Prozorova I.V., Martynenko Y.A., Irkimbekov R.A., Popov Y.A., Suraev A.S., Gnyrya V.S., Sabitova R.R., Medetbekov B.S. (2023) Definition of Thermophysical Parameters of the IVG.1M reactor core with LEU fuel. *Neutron Spectroscopy. Nuclear structure. Related topics*. Russia, Dubna, 59 – 66. Available at: <http://isinn.jinr.ru/proceedings/isinn-29/pdf/Prozorova.pdf>
- 6 Irkimbekov R., Vurim A., Vityuk G., Zhanbolatov O., Kozhabayev Z., Surayev A. (2023) Modeling of Dynamic Operation Modes of IVG.1M Reactor. *Energies*, 16, 932. DOI:10.3390/en16020932.
- 7 Irkimbekov R.A., Zhagiparova L.K., Kotov V.M., Vurim A.D., Gnyrya V.S. (2019) Neutronics Model of the IVG.1M Reactor: Development and Critical-State Verification. *Atomic Energy*, 127, 69–76. DOI:10.1007/s10512-019-00587-1.
- 8 Martynenko E.A., Erdybayeva N.K., Akaev A.S., Bekmuldin M.K., Turkach A.A. (2023) Kompyuternoe modelirovanie raspredeleniya temperatury TVS reaktora IVG.1M. *Bulletin of Toraigrov University. Energetics series*, 3, 197 – 209. DOI: 10.48081/YBCY7199. [in Russian]
- 9 Khazhidinov A.S., Akayev A.S., Ganovichev D.A. (2019) Computation of a temperature field of the IVG.1M WCTC-LEU in optimized and advanced models. *NNC RK Bulletin*, 3, 76-80. DOI:10.52676/1729-7885-2019-3-76-80. [In Russian]
- 10 Khazhidinov A.S., Ganovichev D.A., Akaev A.S., Martynenko Ye.A., Khazhidinova A.R. (2018) Validation of the thermophysical model of IVG.1M reactor WCTC-LEU. *NNC RK Bulletin*, 3, 45-49. DOI:10.52676/1729-7885-2018-3-45-49. [In Russian]
- 11 Zaytsev D.A., Repnikov V.M., Soldatkin D.M., Solntsev V.A. (2017) Studies of behavior of the fuel compound based on the U-Zr micro-heterogeneous quasilloy during cyclic thermal tests. *Journal of Physics: Conference Series*, 891(1). DOI:10.1088/1742-6596/891/1/012181.
- 12 ANSYS Fluent Workbench Tutorial Guide Release 2021 R2. (2021), ANSYS Inc., Southpointe. Available at: [https://dl.cfdexperts.net/cfd\\_resources/Ansys\\_Documentation/Fluent/Ansys\\_Fluent\\_Workbench\\_Tutorial\\_Guide\\_2021\\_R2.pdf](https://dl.cfdexperts.net/cfd_resources/Ansys_Documentation/Fluent/Ansys_Fluent_Workbench_Tutorial_Guide_2021_R2.pdf)
- 13 Bruyaka A., Fokin V.G., Soldusova E.A., Glazunova N.A., Adeyanov I.E. (2010) *Inzhenernyy analiz v ANSYS Workbench*, Samar.gos.tekhn.un-t, Samara, 217 p. [In Russian] Available at: <https://studizba.com/show/1041590-2-bruyaka-va-inzhenernyy-analiz-v-ansys.html>
- 14 Sabitova R.R., Popov Yu.A., Irkimbekov R.A., Prozorova I.V., Bedenko S.V. (2023) Calculated and experimental data on energy release profile in the fuel assembly of the IVG.1M reactor after fuel enrichment reduction. *NNC RK Bulletin*, 83-87. DOI:10.52676/1729-7885-2023-1-83-87. [In Russian]

15 Bobkov V.P., Fokin L.R., Petrov E.E., Popov V.V. Rumiantsev V.N., Savvatimsky A.I. (2008) *Thermophysical Properties of Materials for Nuclear Engineering: A Tutorial and Collection of Data*, International Atomic Energy Agency, Vienna, 2000 p. Available at: [https://www-pub.iaea.org/MTCD/Publications/PDF/IAEA-THPH\\_web.pdf](https://www-pub.iaea.org/MTCD/Publications/PDF/IAEA-THPH_web.pdf)

16 Rivkin S.L., Aleksandrov A.A. (1984) *Termodinamicheskie svoystva vody i vodyanogo para*. Energoatomizdat, Moscow, 84 p. [In Russian] Available at: <https://studizba.com/show/850980-14-.html>

17 Miheev M.A., Miheeva I.M. (1977) *Osnovy teploperedachi*, Energiya, Moscow, 344 p. [In Russian] Available at: <https://studizba.com/show/1013624-1-osnovy-teploperedachi-miheev-ma.html>

## AUTHORS' INFORMATION

**Skakov, Mazhyn Kanapinovich** - Doctor of phys.-math. sciences, Professor, Chief Researcher, National Nuclear Center of the Republic of Kazakhstan, Kurchatov, Kazakhstan; Scopus Author ID: 6506859122; ORCID iD: 0000-0003-3716-8846; [skakov@nnc.kz](mailto:skakov@nnc.kz)

**Martynenko, Yekaterina Alexandrovna** - PhD Student, Chief of Group, Institute of Atomic Energy Branch of RSE NNC RK, Kurchatov, Kazakhstan; D. Serikbayev East Kazakhstan Technical University, Ust-Kamenogorsk, Kazakhstan; Scopus Author ID: 57854824300; ORCID iD: 0000-0002-1423-4524; [Kirichek@nnc.kz](mailto:Kirichek@nnc.kz)

**Yerdybayeva, Nazgul Kadyrbekovna** - Doctor of phys.-math. sciences, Professor, D.Serikbayev East Kazakhstan Technical University, Ust-Kamenogorsk, Kazakhstan; Scopus Author ID: 36633438100; ORCID iD: 0000-0003-0314-0503; [nyerdybayeva@mail.ru](mailto:nyerdybayeva@mail.ru)

**Akayev, Asan Sabyrovich** - Head of Department, Institute of Atomic Energy Branch of RSE NNC RK, Kurchatov, Kazakhstan; Scopus Author ID: 57321455500; ORCID iD: 0000-0003-4792-6161; [akaev@nnc.kz](mailto:akaev@nnc.kz)

**Bekmuldin, Maksat Kuatbekovich** - PhD Student, Chief of Laboratory, Institute of Atomic Energy Branch of RSE NNC RK, Kurchatov, Kazakhstan; Scopus Author ID: 57321072600; ORCID iD: 0000-0002-6895-536X; [bekmuldin@nnc.kz](mailto:bekmuldin@nnc.kz)

**Prozorova, Irina Valentinovna** - Head of Laboratory, Institute of Atomic Energy Branch of RSE NNC RK, Kurchatov, Kazakhstan; Scopus Author ID: 57220986470; ORCID iD: 0000-0001-8701-9756; [prozorova@nnc.kz](mailto:prozorova@nnc.kz)