

MICROSTRUCTURE EVOLUTION OF STEEL-ALUMINUM WIRE DURING DEFORMATION BY "EQUAL-CHANNEL ANGULAR PRESSING-DRAWING" METHOD

Volokitina I.E.^{1*}, Volokitin A.V.², Panin E.A.², Latypova M.A.², Kassymov S.S.³

¹ Rudny Industrial Institute, Rudny, Kazakhstan, irinka.vav@mail.ru

² Karaganda Industrial University, Temirtau, Kazakhstan

³ E.A. Buketov Karaganda University, Karaganda, Kazakhstan

During experimental studies of the equal-channel angular pressing-drawing effect on the microstructure evolution and mechanical properties change, the principal possibility and effectiveness of using the proposed continuous method for forming an ultrafine-grained structure and increasing the strength properties of steel-aluminum wire was proved. The deformation was carried out at ambient temperature in three passes. It is shown that both layers of bimetallic wire are processed unevenly. An aluminum shell with an initial grain size of 22 microns was processed up to 2 microns. The steel core has a different grain size in the transverse and longitudinal sections. With an initial grain size of 18 microns, after deformation the grain size is about 10 microns in the longitudinal section and 8 microns in the transverse section.

Keywords: severe plastic deformation, microstructure, bimetallic wire, steel, aluminum, mechanical properties.

Introduction

Currently, bimetallic materials representing a combination of metals or alloys with different physical and mechanical properties are widely used in various industries around the world [1-3]. The metal products obtained from these materials, including rods and wire, determine the safety and reliability of the functioning of railways, telephone wires, cables, objects of the defense industry, aviation, etc. For example, in the cable industry, the material for a conductive core is used by volume, not by weight. This means that 1 ton of aluminum can be used to make 3.2 times the length of a wire of the same diameter than 1 ton of copper. Another important point is the price per unit of mass. Aluminum is much cheaper than copper. The price difference is constantly changing depending on the demand for materials and their availability, not to mention speculation in the metal markets, but aluminum is always about 2-3 times cheaper than copper. Therefore, the use of bimetallic wire in the production of high-frequency cables is most advantageous [4-5]. Due to the surface effect, the current flows only in a very thin part of the wire near the outer surface. The thickness of this layer depends on the frequency at which the cable is operated.

Currently, due to the large difference in the prices of copper and aluminum, the transmission of electricity through cable products with a conductive core made of bimetallic wire is of increasing interest. In recent years, the following types of bimetallic wire have been widely used in industry:

- steel-copper wire, which is used for overhead lines of weak and strong current and the manufacture of wires;
- steel-aluminum wire used for the manufacture of heating elements.

Bimetallic rods are also widely used, including, for example, copper-aluminum current-carrying rods. The replacement of copper in the production of current-carrying wires with aluminum clad with a thin layer of copper makes it possible to reduce the metal consumption of products while maintaining high electrical conductivity. The main quality indicators of bimetallic wire and rods are the combination of their strength and plastic properties. At the same time, the main properties of the bimetallic material of wire and rods, as a structural material, are structurally sensitive, that is, they can be controlled by purposeful changes in the structure during pressure treatment [6-8].

In conditions of a shortage of energy and raw materials, the development of resource-saving methods for obtaining bimetallic materials with properties that combine high strength and plasticity at the same time, using

relatively simple and inexpensive devices that allow spending the minimum possible amount of time when processing products, is very relevant.

One of the most promising directions for improving the strength and plastic properties of bimetallic wire is the formation of an ultrafine-grained (UFG) structure in materials by deformation methods. In this regard, severe plastic deformation (SPD) methods are actively developing, mainly implementing a simple shear scheme under conditions of multi-cycle processing [9-15]. Obtaining this type of structure makes it possible to significantly increase the strength characteristics of metal materials [16-19]. Therefore, the search for high-performance schemes for the formation of UFG structures in metals based on traditional metal forming processes is an important stage in the further development of SPD processes. A special place among these methods is occupied by the "equal-channel angular pressing-drawing" (ECAP-drawing) combined process [20-22]. Its key feature is that, unlike other combined methods, there is no rolling stage here. The continuity of deformation is ensured by the drawing process, which takes place immediately after the ECAP process. In connection with the above, the task of studying the regularities of structural changes in bimetallic steel-aluminum wire during deformation by the "ECAP-drawing" method, as well as establishing a connection between the structural state of the material before and after deformation, is urgent. This will make it possible to significantly advance in understanding the ongoing processes and predict the complex of mechanical properties of such blanks.

1. Experimental part

Based on the modeling given in [23-24], the design of tools and accessories for the stand implementing the "ECAP-drawing" combined process was carried out. A matrix for equal-channel angular drawing is designed, consisting of upper and lower segments, repeating the bend of the channel (Figure 1a). The geometric dimensions of the matrix are taken, according to the results obtained during modeling in the Deform software package. The design of all component parts is carried out in the KOMPAS-3D software package (Figure 1b). To check the correctness of the geometric dimensions, as well as the fitting and docking of all the components of the matrix, the tools and accessories were assembled in the KOMPAS-3D software package (Figure 2).

According to the drawing shown in Figure 1a, the matrix was made in the metal structures workshop of Kurylysmet LLP. The matrix segments are made of 5HV2S stamp steel. After manufacturing, the matrix was subjected to heat treatment to increase the hardness and strength. Based on the results of the simulation, the inclination angle between the channels of the matrix was assumed to be equal to 135° . This angle ensures the dominance of shear (non-destructive) stresses over normal (destructive) stresses. There are no rounding at the joints of the matrix channels in order to intensify shear deformations.

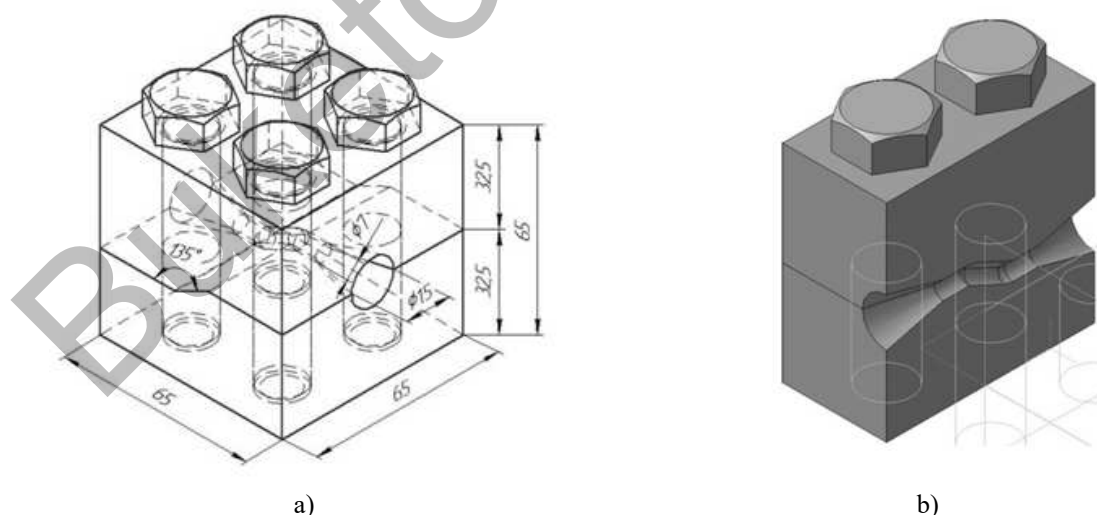

Fig.1. Matrix for equal-channel angular drawing: a) - matrix scheme, b) - 3D model

A bimetallic wire consisting of a core of 65G steel and an outer layer of AL6063 aluminum with a diameter of 8 mm was used as the initial billet, the diameter of the steel core was 6.5 mm. The laboratory experiment was carried out on an industrial drawing mill B-I/550 M. An equal-channel step matrix with a channel diameter of 10.0 mm and a junction angle of the matrix channels of 135° was fixed before the drawing

tool. The matrix was located in a lubrication container. The deformation was carried out in three passes. The initial diameter of the blank was 8.0 mm. Hard-alloy drawing tools with polished channels, reduced taper angles of the working zone and smooth transitions from one zone to another were used for drawing stage. Bimetallic wire surface preparation for drawing was carried out according to the usual technology for steel wire, a mixture of soap and sulfur powders was used as a lubricant. The speed of the wire was 10.0 mm/s through the matrix, and 13.6 mm/s through the drawing die.

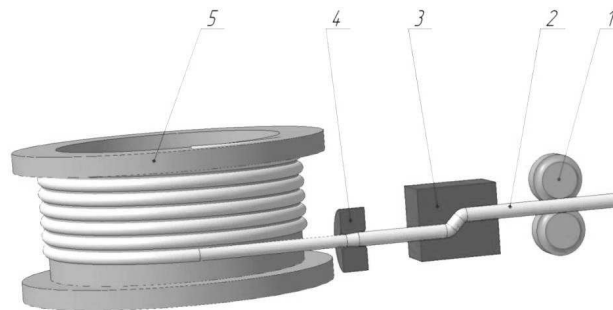

Fig.2. Tool assembly: 1 - setting device; 2 - wire; 3 - equal-channel step matrix; 4 – drawing tool in holder; 5 - winding drum

For the study the samples with a length of 15 mm of steel-aluminum wire were cut out, then micro-sections were prepared on the end sides of these blanks. For the preparation convenience and the blockages absence, the plane slots were fixed in a clamp. To prevent the removal of the aluminum layer, depressions with a cylindrical surface were made in the clamp, the radius of which corresponded to the radius of the wire.

To identify the structural elements of 65G steel, the micro-sections were etched in an alcoholic solution of nitric acid (4 cm³ of nitric acid and 96 cm³ of ethyl alcohol) for 5-10 seconds. Etching of the aluminum surface was performed with a 5% NaOH solution at a temperature of 70-80°C for 1.5 minutes.

The samples preparation for metallographic analysis was carried out at the Struers electrolytic sample preparation unit. All samples were examined in the middle plane of the sample to avoid the influence of peripheral areas. The obtained samples were considered in transverse and longitudinal sections. The structure and phase composition were analyzed using optical microscopy. Qualitative and quantitative analysis of the main mass microstructure and primary phases was carried out using a LEICA optical microscope equipped with a nozzle for determining the microhardness of individual phases, as well as software for determining the degree of granularity and the number of phases on mechanically polished and etched samples.

2. Results and discussion

Figure 3 shows photos of the microstructure of bimetallic wire in the initial state and after three passes of deformation by the "ECAP-drawing" method in longitudinal and transverse sections. The initial grain size of the aluminum shell before deformation was 22 microns, the grain size of steel core was 18 microns (Figure 3a). The structural heterogeneity formed as a result of diffusion processes at various stages of technological operations for the production of bimetallic wire is revealed at the boundary of the connection of steel and aluminum. Metallographic studies have shown that the "ECAP-drawing" process leads to a significant change in the bimetallic wire structure. The most significant changes occur in the surface layers of the aluminum shell (Figure 3b-c). After 3 deformation cycles, a fragmented structure with equiaxed grains is formed in the steel core in both transverse and longitudinal sections. Moreover, in the longitudinal section, the grain size is about 10 microns (Figure 3 d), and 8 microns in the transverse section (Figure 3 e).

In addition, there is a fragmentation of pearlite areas. The thickness of the crushed aluminum layer continuously increases with the number of passes, and after the third pass, the structure becomes almost uniform. The grain size formed after 3 deformation cycles is 2 microns. The results of tensile tests showed that the strength properties of the wire, even after three deformation passes significantly increase compared to the initial state. The tensile strength was increased from 370 MPa in the initial state to 765 MPa after the third pass. The yield strength increased from 260 MPa up to 515 MPa after the third pass.

At the same time, the relative elongation was 22%, while the initial one was 32%. A slight drop in the plastic properties of steel-aluminum wire can be explained by the formation of an ultrafine-grained structure with large-angle nonequilibrium boundaries capable of shear [25].

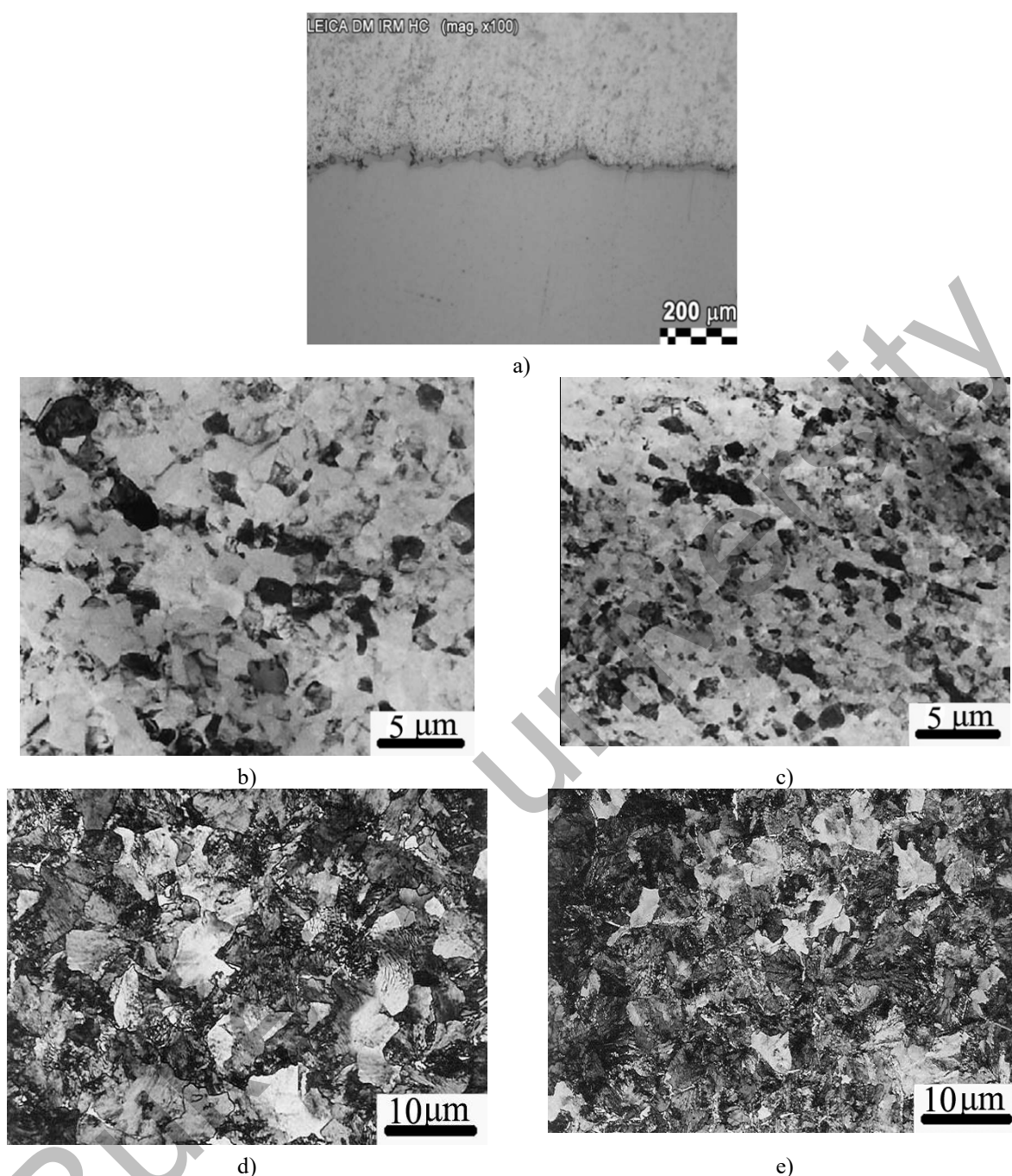

Fig.3. Microstructure of bimetallic steel-aluminum wire: a) – initial state; b) - aluminum shell (longitudinal section); c) - aluminum shell (transverse section); d) - steel core (longitudinal section); e) – steel core (transverse section)

Conclusion

The study confirmed the regularity of deformation hardening of bimetallic wire. A significant change in the microstructure, initiated by the combination of equal-channel angular pressing with drawing of steel-aluminum wire, allowed achieving the following most important results:

1. During the deformation of the steel core, which determines the strength properties of the steel-aluminum wire, there is fragmentation of ferrite and crushing of pearlite sections in the longitudinal section up to 10 microns, and up to 8 microns in the transverse section.

2. The strength properties of the wire after three passes of deformation significantly increase compared to the initial state. The tensile strength was increased from 370 MPa to 765 MPa. The yield strength was

increased from 260 MPa to 515 MPa. At the same time, the relative elongation was reduced to 22% from the initial 32%.

3. The combination of equal-channel angular pressing with drawing allows not only the composition strengthening, but also at the same time to increase the plastic properties of products regulated by a number of standards. This circumstance favorably distinguishes the investigated method from other traditional types of wire metal forming.

Acknowledgments

This research was funded by the Science Committee of the Ministry of Education and Science of the Republic of Kazakhstan (Grant No. AP08052852).

REFERENCES

- 1 Chukin M.V., Polyakova M.A., Emaleeva D.G., Gulina A.E. Creating Ultrafine Grain Structure in High Strength Bimetallic Steel–Copper Products. *Steel in Translation*. 2014, Vol. 44, No. 4, pp. 320–323.
- 2 Lee K.S., Jun H.J., Lee Y.S. Fabrication of bimetallic rods consist of a Zr-based BMG and a crystalline copper by co-extrusion. *Intermetallics*. 2010, Vol. 18, pp. 1958-1963.
- 3 Llorca-Isern N., Escobar A.M., Roca A., Cabrera J. Equal Channel Angular Pressing of Cu-Al Bimetallic Rod. *Materials Science Forum*. 2012, Vol. 706-709, pp. 1811-1816.
- 4 Acarer M. Electrical, corrosion, and mechanical properties of aluminum-copper joints produced by explosive welding. *Journal of Materials Engineering and Performance*. 2012, Vol. 21, pp. 2375–2379.
- 5 Alizadeh M., Samiei M. Fabrication of nanostructured Al/Cu/Mn metallic multilayer composites by accumulative roll bonding process and investigation of their mechanical properties. *Materials and Design*. 2013, Vol.56, pp. 680-684.
- 6 Eivania A.R., et al. Investigation of joint interface and cracking mechanism of thick cladding of copper on aluminum by equal channel angular pressing (ECAP). *Journal of Materials Research and Technology*. 2020, Vol. 9(3), pp. 3394–3405.
- 7 Chen C.-Y., Chen H.-L., Hwang W.-S. Influence of interfacial structure development on the fracture mechanism and bond strength of aluminum/copper bimetal plate. *Materials Transaction*. 2006, Vol. 47, pp.1232-1239.
- 8 Volokitina I., Volokitin A., Naizabekov A., et al. Microstructure of bimetallic wire in the “ECAP-drawing» process. *Journal of Chemical Technology and Metallurgy*. 2021, Vol. 56, No. 4, pp.857-866.
- 9 Lezhnev S., Panin E., Volokitina I. Research of combined process rolling-pressing influence on the microstructure and mechanical properties of aluminium. *Advanced Materials Research*. 2013, Vol.814, pp. 68-75.
- 10 Valiev R.Z., Estrin Y., Horita Z., et al. Producing bulk ultrafine-grained materials by severe plastic deformation: ten years later. *JOM*. 2016, Vol. 68, pp.1216-1226.
- 11 Furukawa M., Horita Z., Langdon T.G. Application of equal-channel angular pressing to aluminum and copper single crystals. *Materials Science Forum*. 2007, Vols. 539-543, pp. 2853-2858.
- 12 Surzhikov A.P., Lysenko E.N., Malyshev A.V., et al. Phase transformations in ferrites during radiation-thermal sintering. *Eurasian Physical Technical Journal*. 2020, Vol. 17, No.1, pp. 26-34.
- 13 Haddad M., Ivanisenko Y., Fecht H.J. Behavior of C45 steel Subjected to Different High Pressure Torsion (HPT) Procedures. *International Journal of Applied Science and Technology*. 2015, Vol. 5, No. 1, pp. 144-153.
- 14 Naseri R., et al. An experimental investigation of casing effect on mechanical properties of billet in ECAP process. *International Journal of Advanced Manufacturing Technology*. 2017, Vol. 90, pp. 3203–3216.
- 15 Polyakov A.V., Semenova I.P., Raab G.I. Peculiarities of ultrafine-grained structure formation in Ti Grade-4 using ECAP-Conform. *Advanced Materials Science*. 2012, Vol.31, pp. 78-84.
- 16 Xiao W., Wang B., Wu Y., Yang X. Constitutive modeling of flow behavior and microstructure evolution of AA7075 in hot tensile deformation. *Materials Science and Engineering A*. 2018, Vol. 712, pp.704-713.
- 17 Kasenov B.K., Kasenova Sh.B., Sagintaeva Zh.I., et al. Synthesis and X-ray investigation of novel nanostructured copper-zinc manganites of lanthanum and alkali metals. *Eurasian Physical Technical Journal*. 2021, Vol. 18, No.1, pp.29-33.
- 18 Chung K., Ahn K., Yoo D.-H., et al. Formability of TWIP (twinning induced plasticity) automotive sheets. *International Journal of Plasticity*. 2011, Vol. 27, No. 1, pp. 52-81.
- 19 Alizadeh M., Samiei M. Fabrication of nanostructured Al/Cu/Mn metallic multilayer composites by accumulative roll bonding process and investigation of their mechanical properties. *Materials & Design*. 2014, Vol. 56, pp. 680–684.
- 20 Volokitina I.E., Volokitin A.V. Evolution of the Microstructure and Mechanical Properties of Copper during the Pressing–Drawing Process. *Physics of Metals and Metallography*. 2018, Vol. 119, pp. 917-921.
- 21 Lezhnev S.N., Naizabekov A.B., Volokitin A.V., Volokitina I.E. New combined process pressing-drawing and impact on properties of deformable aluminum wire. *Procedia Engineering*. 2014, Vol. 81, pp. 1505–1510.
- 22 Naizabekov A., Volokitina I., Volokitin A., Panin E. Structure and mechanical properties of steel in the process "pressing-drawing. *Journal of Materials Engineering and Performance*. 2019, Vol. 28, No. 1, pp. 1762-1771.
- 23 Volokitina I., Volokitin A., Naizabekov A., Panin E. FEM-study of bimetallic wire de-formation during combined ECAP-drawing. *Journal of Chemical Technology and Metallurgy*. 2021, Vol.56, No. 2, pp.410-416.
- 24 Volokitina I., Volokitin A., Naizabekov A., Lezhnev S., Panin Ye. Deformation of bimetallic wire during combined ECAP-Drawing. *Proceeding of the 29th Intern. Conf. on Metallurgy and Materials*, Brno, 2020, pp. 183-189.
- 25 Valiev R. Nanostructuring of metals by severe plastic deformation for advanced properties. *Nature Materials*. 2004, Vol.3, pp.511–516.