

The object of the study is coal sludge and coal fines of the Shubarkol deposit and the Kuznetsk coal basin (Republic of Kazakhstan) for the production of coal-water fuel, which allows replacing liquid and gaseous expensive products. The resulting fuel (after treatment of coal seams and burial) from industrial waste should not harm the environment, which requires certain economic investments. For crushing coal and coal sludge in the crushing and grinding unit, an electrohydroimpulse device for fine grinding of materials was used, consisting of a control unit with a protection system, a pulse capacitor and a high-voltage generator (capacitor bank capacity 0.75 μF , pulse discharge voltage 15–30 kV, length of the interelectrode distance 7–10 mm). After grinding, fine coal particles rise to the surface of the water, and impurities settle at the bottom of the device, which allows enriching the product (flotation). Surface structures and coal fraction sizes were obtained using a Tescan Mira 3 scanning electron microscope. The main characteristics of coal-water fuel during vortex combustion were: the diameter of the fraction 0–250 microns – 63–74 %, process water – 36–24 %, special additive – 1–2 %. Coal-water fuel is similar to liquid fuel, and when transferring heat-generating plants to combustion of suspension, no significant changes in the design of boilers (units) are required. This makes it easy to mechanize and automate the processes of receiving, feeding and burning fuel, and the vortex combustion technology at a temperature of 950–1050 °C guarantees fuel efficiency of more than 97 %. The given optimal parameters of electrohydroimpulse technology when introduced into production will allow not only grinding, but also enriching the coal product

Keywords: coal-water suspension, electrohydraulic effect, coal sludge, plasticizer

DEVELOPMENT OF TECHNOLOGY FOR OBTAINING COAL-WATER FUEL

Bekbolat Nussupbekov

Corresponding author

Candidate of Technical Sciences Science, Professor*

E-mail: bek_nr1963@mail.ru

Ayanbergen Khassenov

Doctor of Philosophy (PhD)*

Ulan Nussupbekov

Doctoral Student

Faculty of Physics and Technology***

Bektursin Akhmediyev

Master of Physical Sciences**

Dana Karabekova

Doctor of Philosophy (PhD)*

Bayan Kutum

Master of Physical Sciences**

Nazgul Tanasheva

Doctor of Philosophy (PhD)**

*Department of Engineering Thermophysics named after Professor Zh. S. Akylbayev***

Alternative Energy Research Center*

***Karaganda Buketov University

University str., 28, Karaganda, Republic of Kazakhstan, 100028

Received date 02.05.2022

Accepted date 21.06.2022

Published date 30.06.2022

How to Cite: Nussupbekov, B., Khassenov, A., Nussupbekov, U., Akhmediyev, B., Karabekova, D., Kutum, B., Tanasheva, N.

(2022). Development of technology for obtaining coal-water fuel. *Eastern-European Journal of Enterprise Technologies*,

3 (8 (117)), 39–46. doi: <https://doi.org/10.15587/1729-4061.2022.259734>

1. Introduction

Currently, due to the rapid development of the fuel and energy complex, the volume of solid fuel consumed is increasing every year. As it is known from the material of research [1], in the world practice, energy systems suffer from several problems, such as various environmental problems, as well as long-term energy security is questioned. In this regard, they propose to use renewable energy in the future, mainly solar and wind, and the latter in the long-term production of lithium and also phosphorous ore. However, until such technologies are created, traditional energy sources will be available.

The main task in the process of preparing coal-water fuel is the grinding of coal. For grinding coal in production, ball, shaft and vibration mills of dry or wet grinding are used. The disadvantages of these mills are as follows: the complex and expensive design of their structures, due to the wear of the working bodies for crushing the material, the resulting product becomes dirty.

Therefore, research on the development of technology for producing coal-water fuel using the electrohydraulic effect is relevant.

2. Literature review and problem statement

In the work of the author [2], the prospects for using coal-water fuel are well described. Currently, this direction is very relevant not only for Ukraine, but also Western Europe, since more than 80 % of the total fuel balance of Ukraine is natural gas. The shortage of energy resources, including natural gas and oil, would help energy companies to additionally create and use alternative fuel sources.

Therefore, in subsequent works we tried to consider some of the advantages and disadvantages of creating and using coal-water fuel. The author's work [3] shows the proportions of the use of coal mixtures of various fractions (50–75 % coal, with a maximum particle size of about 300 microns; 25–50 % water; 1 % additives, such as dispersants or surfac-

tants). However, due to the different grades of coal, as well as the inaccuracy of the studies carried out, it is impossible to estimate the exact proportion.

In [4], it is shown that mechanical crushers are used for crushing and grinding solid particles (coal, coal sludge, etc.) and obtaining stable binary fuel systems, which, in turn, have certain disadvantages, including they are energy-intensive and require high energy consumption, and after grinding products, metallic impurities appear in them. These impurities can negatively affect the operation of not only the injectors, but also the entire fuel system.

It was shown in [5] that the rheology of the mixtures obtained was studied mainly by experiments with suspended suspension particles, and on this basis, correlations were obtained to predict the Newtonian viscosity of the suspension. However, as is known, particles of various materials (coal, sludge, charcoal, etc.) will differ in physical and geometric properties, such as density and shape. Thus, the actual flow pattern for pumping through the pipeline will differ depending on the material (charcoal, sludge, etc.).

In [6], separate methods for the preparation of suspensions (non-Newtonian suspensions) and their behavior are indicated, which will be used for commercial purposes, but this type of fuel is very different from traditional combustion materials. Therefore, it is difficult to evaluate it in practical applications.

The paper [7] experimentally investigated and obtained comparative data on the ignition behavior of slurry fuel prepared from peat, coal processing waste (sludge and filtration sludge) and brown coal with the addition of spent turbine oil (with a share of 10 %), compared with traditional fuels. As is known, due to the high cost and shortage of spent turbine oil, it is impossible to use these additives for the preparation of coal-water fuel.

It is known from the works of the authors [8] that waste is generated at enterprises during extraction, as well as after processing any type of fuel. With poor-quality flotation and dehydration of small-grade coal, coal sludge is formed. This level is about 0.5–10 % of the total volume of processed coal, and storage facilities and hydraulic settling tanks using sludge occupy huge territories, and coal in the sludge is intensively oxidized. This process greatly affects the environment and is harmful from an ecological point of view. Therefore, further processing of coal sludge for use in the energy sector is an urgent task and, as is known, requires a certain amount of energy consumption.

As the authors [9] show, the creation of a suspension coal-water fuel with subsequent transportation of sludge will dramatically improve the environmental situation. Considering that the cost of the fuel component in the cost of the generated thermal energy ranges from 40 to 70 %, reducing the cost of fuel or its specific consumption is an important factor in obtaining an economic effect.

The paper [10] describes the technological, qualitative and quantitative scheme, as well as the calculated data of technical and economic indicators of the technology of preparation of water-coal fuel based on brown coal. The possibility and prospects of using coal-water fuel in Ukraine obtained using the “hot water drying” technology are shown. The efficiency of using various heat carriers at power plants in Ukraine is considered, as well as technical and elemental analysis of brown coal from the Alexandrian deposit, from which it is possible to obtain coal-water fuel with a capacity of 120 tons/day according to the proposed technological

scheme. Such schemes are optimal and workable. It is necessary to further develop such technological lines.

The authors of the works [11] carried out fuel studies in the plane of ensuring the maximum concentration of solid particles, efficient combustion of coal-water suspension and in-depth fundamental study of the rheology and stability of coal-water fuel from the standpoint of the theory of lyophobic stability of colloids.

In the field of the theory of highly concentrated coal-water suspensions, the authors propose three approaches: classical hydrodynamic, empirical and somewhat unconventional, based on the physical theory of stability of colloidal systems (DLFL theory). At the same time, the stage of development of the physical and technical bases for the preparation of coal-water fuel transportation has been completed. However, these processes take a colossal time to implement such technologies.

The authors of the works [12] show a very promising technology, this is the use of highly loaded coal-water sludge (HLCWS) as fuel and the production of stably transported coal-water fuel (CWF), which can be burned in boilers without prior dehydration. This process dramatically reduces transport costs. Also, the theory of highly loaded coal-water suspensions (HLCWS) can be supplemented by an analysis of the energy state of the HLCWS solid phase using important assumptions of the theory of aggregative stability of lyophobic dispersion systems (DLVO theory).

In addition, universal technologies for efficient combustion of water-coal fuel of crushed coal waste have not yet been developed.

In connection with the above, the development, creation and implementation of alternative fuel sources in the thermal power industry is an urgent task.

3. The aim and objectives of the study

The aim of the study is to develop an electrohydraulic technology for producing coal-water fuel from coal and coal sludge.

To achieve the aim, the following objectives were set:

- to determine the discharge energy and the length of the discharge gap of the electrohydroimpulse installation, providing fine grinding of coal particles to a specified size (0.1–200 microns);
- to develop and manufacture a nozzle with a tangential twist for spraying coal-water fuel.

4. Materials and methods

To carry out experimental studies, we obtained coal with a diameter of 7–48 mm, products from the coal mine of Shubarkol Komir JSC, coal sludge and coal from the Kuznetsk mine coal basin prepared in the central processing plant.

The resulting products were processed mechanically using a VKDM-6 mechanical crusher [13, 14] and an experimental electrohydropulse installation with a crushing and grinding unit.

Before the experiment, the original type of coal was subjected to crushing into certain fractions by mechanical means. Before placing the coal in the working cell, the coal was weighed on electronic scales of 50, 100, 150 and 200 g. After processing, the obtained samples were dried and separated into fractions of various sizes. Particle size mea-

measurements were carried out by sieving using a sieve with the following cell size: 1,000, 500, 300, 250, 200, 100 and 80 microns.

The experimental setup works as follows. After the voltage is applied, the transformer generates a pulse voltage of the required energy and through the electrode cable (radio frequency coaxial cable with a nominal impedance of 75 ohms), into the system of the working crushing unit with the object of study. The power supply is carried out from the mains, with a voltage of 220 V. The pulse voltage generator is assembled on a step-up high-voltage transformer Tr, with a transformation coefficient $t=200$, with a maximum voltage of 50 kV and is designed for a current of 100 mA in nominal operating mode.

The installation has a cylindrical chamber (crushing and grinding unit), where two electrodes are installed, one of which is negative – stationary, and the second positive electrode (Fig. 1). The latter is regulated depending on the loading of the object and allows one to change the supply pulse voltage. The gap between the electrodes can be changed from 0.1 mm to 15 mm.

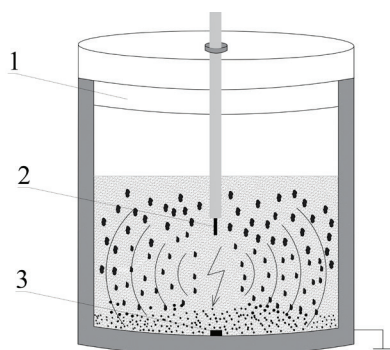

Fig. 1. Crushing and grinding unit: 1 – unit cover; 2 – positive central electrode; 3 – grounding and negative electrode

The upper part of the cell cover is made of a special non-conductive material (caprolon). In this crusher, the process takes place in an aqueous medium, and therefore dust is not formed and the crushing unit occupies a small space. During the crushing process, harmful substances and toxic gases contained in solid fuel, dangerous to human life, do not spread in the environment and remain in the composition of water.

The second series of experiments was carried out with the use of a crushing and grinding device created and manufactured by us to obtain fine materials [12].

In this device, two stages of grinding are used, first in the main body, larger fractions, due to cone reflectors mounted in the built-in housing in the form of additional electrodes, are crushed to medium for grinding materials of larger fractions (diameter from 10 to 20 mm). And at the second stage, in the built-in housing, the medium fractions are crushed to small fractions, depending on the diameter of the sieve. For an intensive grinding process, the inner cavity performs the function of a reflector. Fig. 2 shows the general scheme of the device.

The main body of this device is designed to supply the source material and liquid. A camera for collecting the finished product with a removable sieve is installed from the bottom of the built-in housing with the help of a thread (during the experiment we also replaced it with other sizes). The positive working electrodes are connected to the dis-

charge distributor and are connected to a high-voltage energy storage. The negative working electrodes are grounded.

In the housing, there is a branch pipe for the intake of finely ground material connected to the filter of the shipping hopper, which is connected to the pump by means of a pipeline. The filter of the shipping hopper has a nozzle for the release of the final product with a flap.

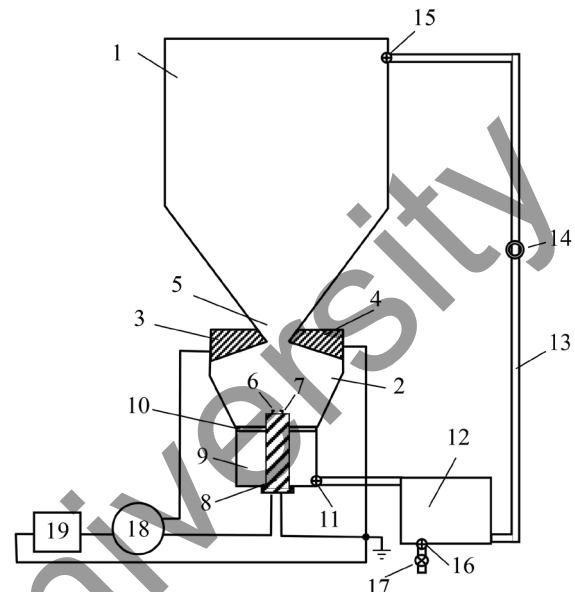

Fig. 2. Electrohydroimpulse device for fine grinding of materials: 1 – main body; 2 – built-in housing; 3, 4 – additional positive and negative electrodes; 5 – central cone-shaped hole; 6, 7 – working positive and negative electrodes; 8 – insulator; 9 – chamber; 10 – sieve; 11 – branch pipe; 12 – filter of the shipping hopper; 13 – pipeline; 14 – pump; 15, 16 – branch pipes; 17 – flap; 18 – discharge distributor; 19 – high-voltage energy storage

During the operation of the device, the crushed material with process water was fed into the main body and the pulse generator unit was turned on, supplying high-voltage pulses accompanied by electrical discharges in the working fluid between high-voltage additional electrodes. Materials of a larger fraction located in the housing were subjected to a powerful pulsed electric discharge that occurred during an underwater spark discharge in a liquid. So, the gap of the central cone-shaped hole was not clogged with large pieces, the process of destruction and crushing to the desired fraction was carried out beforehand, after that the material entered the grinding zone of the built-in housing. After receiving the materials on the built-in housing, using working electrodes installed in the insulator, the second stage of grinding was performed. The shock wave propagated in the process water from the breakdown points in all directions and began to grind the material. In the second stage of grinding, the lower part of the additional electrodes performed the function of cone reflectors, the grinding process in the built-in housing became more intensive to obtain finely ground material. The finely ground materials passed through a sieve and entered the chamber, and the crushed material, mixing with process water under the influence of a pump, was fed to the filter of the shipping hopper, which we used to take the crushed product. The drain of the working fluid entered the main body through a branch pipe, which was connected to the main pipeline for the discharge of the purified working fluid

and to the pump. The operation of the installation allows one to work smoothly and ensures the circulation of intensive grinding of the material.

5. Results of obtaining coal-water fuel by an electrohydroimpulse installation and methods of its combustion

5.1. Determination of the optimal energy and geometric parameters of the electrohydropulse installation for obtaining a fine fraction of water-coal fuel

During mechanical machining, we used a VKDM 6 cone laboratory crusher, which allowed grinding the material due to abrasion. As practice shows, this method of crushing and grinding has its drawbacks, namely mechanical compression stresses, where the resistance for rocks is several times greater, low efficiency, etc.

After mechanical processing of Shubarkol coal, fractions with diameters of 1–3 mm have an elongated shape compared to electrohydroimpulse processing. We found exactly the same process after processing the coal of the Kuznetsk open-pit mine.

During electrohydroimpulse processing, the interelectrode distance in the working interval varied from 7 mm to 10 mm (l_w , through each mm), the capacitance of the capacitor banks $C=0.75 \mu\text{F}$ and the maximum voltage on the controlled spark gap showed $U=35 \text{ kV}$, and the initial diameter of the fraction was taken from 5 to 9 mm.

Fig. 3 shows the process of crushing coal from the distance of the interelectrode gap. As experimental work shows, the degree of coal grinding increases with a change in the direction of increasing the interelectrode distance, followed by an increase in the discharge energy. When setting the distance $l_w=7 \text{ mm}$, the voltage at the working interval was $U=17 \text{ kV}$, at $l_w=8 \text{ mm}$ – 23 kV , at $l_w=9 \text{ mm}$ – 28 kV , and at $l_w=10 \text{ mm}$, the kilovoltmeter showed 33 kV .

In these graphs, we can see that as the interelectrode distance increases, the number of fractions with small sizes rises sharply. If the coal fraction is small, the cell is deposited at the bottom so that the discharge at the bottom of the cell is low. The larger the diameter of the coal, the better the process takes place.

In subsequent experiments, we obtained mass fractions after mechanical and electrohydroimpulse processing (Fig. 4, 5). Comparative data were obtained for the required fixed diameters ($d_{fr}>40 \text{ microns}$ and $d_{fr}=200 \text{ microns}$).

As can be seen from Fig. 5, after mechanical and electrohydroimpulse processing, the mass fraction of the fraction with diameters of 900 microns is much smaller than during electrohydroimpulse processing, but after mechanical processing, the diameter of the fraction of 400 microns increases by 35 %, this process can be explained in terms of the width of the

gap between the processing surface of the rotating cone grinder and the base of the apparatus. The required parameters for obtaining coal-water fuel range from 0.1 mm to 0.2 mm, and the electric pulse process allows this limit to be reached.

From the comparative Fig. 6, it can be seen that after the electric pulse treatment, the mass fraction of the fraction with diameters of 0.14 mm is 3 times higher than after mechanical treatment.

Next, we investigated the surface structures of the samples and obtained data from Kuznetsk coal (Fig. 7) on a Tescan Mira 3 scanning electron microscope.

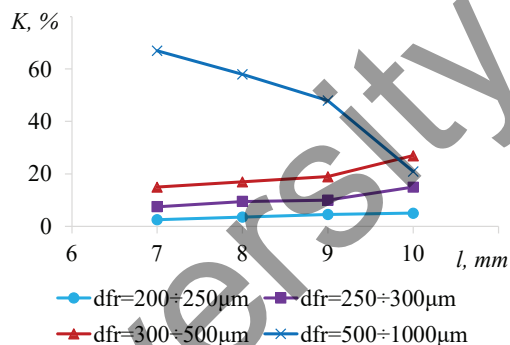

Fig. 3. The crushing process depending on the distance of the interelectrode gap

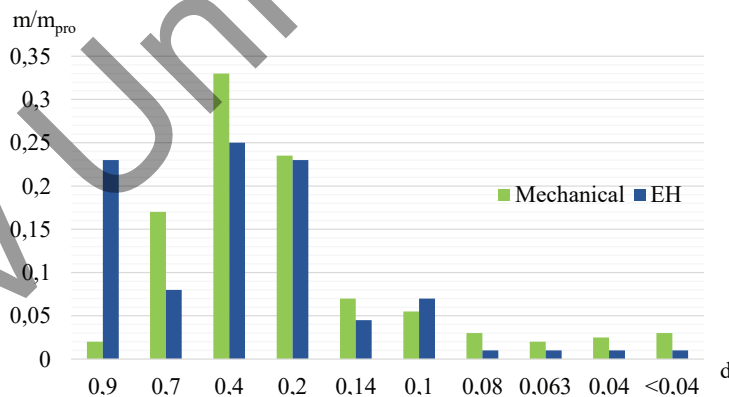

Fig. 4. Histogram of particle distribution during mechanical and electric pulse processing of Kuznetsk coal

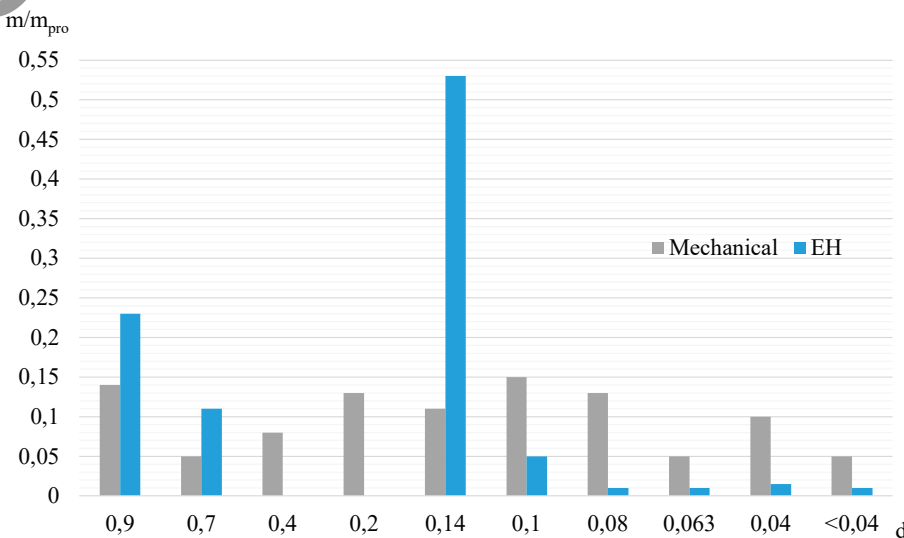

Fig. 5. Histogram of particle distribution during mechanical and electrohydroimpulse processing of Shubarkol coal

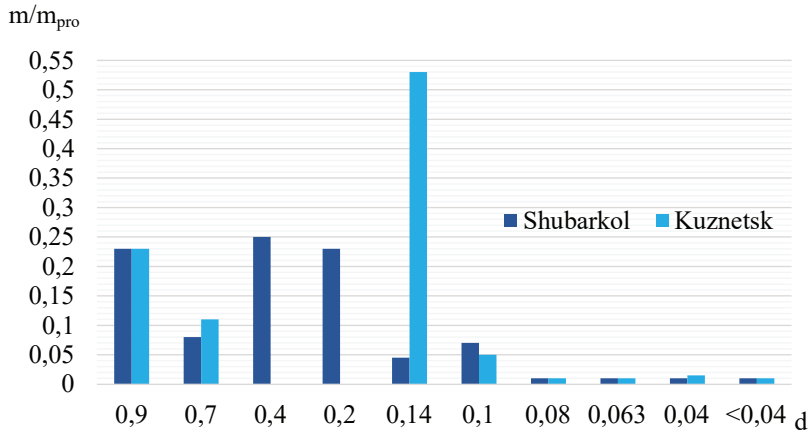

Fig. 6. Distribution histogram of coal particles by size after electrohydroimpulse processing

The Tescan Mira 3 scanning electron microscope allows obtaining SEM images and analyzing the elemental composition in real time in one window of the TESCAN Essence software, which greatly simplifies obtaining data on both the morphology of the sample surface and its local element composition.

The sample particles were fixed on special “tables” using conductive carbon tape, after which the tables were placed in the microscope chamber. The images were obtained using a secondary electron detector (SE detector) at an accelerating voltage (HV) of an electron beam of 20 kV.

The images of the surface were obtained at different magnifications and it is clear that the coal samples have a layered structure.

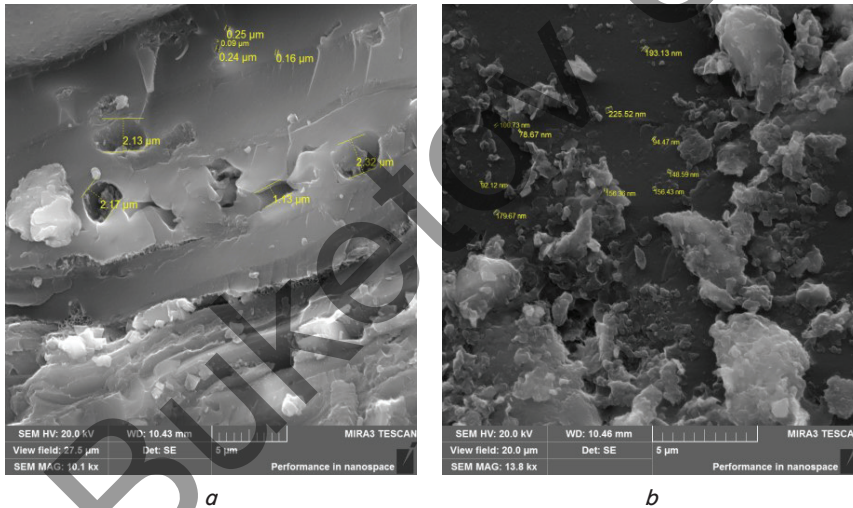

Fig. 7. Electronic images of Kuznetsk coal: *a* – mechanical processing; *b* – electrohydroimpulse processing

Experimental work has been carried out repeatedly. The proposed graphs show only averaged values. At the same time, the measurement error does not exceed 5 % and the errors are within the norm.

The discharge energy was calculated at fixed values of the capacitance of the capacitor bank and the pulse voltage ($W = CU^2/2$):

In experimental studies, pulse capacitors with a nominal voltage of up to 100 kV, with a capacity of 0.25 μF (*C*) (in the amount of 3 pcs) were used. During the experiment, the maximum capacitance of the capacitor bank was – 0.75 μF.

The pulse voltage (*U* – from 15 to 30 kV) was measured and monitored using a C100 mirror kilovoltmeter, where the limit of the permissible value of the basic error in the working part of the scale is ± 2.0 %.

Using digital laboratory scales (maximum load – 1200 g; readout discreteness – 0.01 g), the mass of the feedstock and the crushed product was determined. For each experiment, the mass of the initial product was 200 g, and the crushed coal powder obtained by the electrohydroimpulse method was sieved through a sieve with a hole size of 250 microns. After repeated experiments, the average mass of the resulting product was determined: $mcp = (m1 + m2 + m3 + \dots + mn) / n$.

To determine the granulometric composition of the resulting coal powder, standard laboratory sieve containers with cell sizes from 1 mm to 40 microns were used (the sieve was calibrated in accordance with GOST R 51568-99).

During experimental studies, the measurement error was: for pulse voltage – 3.5 %, for capacitor bank capacity – 2.5 %, by weight of the initial product and the product obtained by the electrohydroimpulse method, about 1 %. The confidence interval does not exceed standard deviations, and therefore is not indicated in the graphs.

5. 2. Creation of a burner device with tangential swirl for atomization of coal-water fuel and testing

In the electrohydrodynamics laboratory, we have designed and developed two types of atomizers with a hearth device for injection of coal-water fuel: with cylindrical radial rotation of the flow; with aerodynamic (tangential) rotation of the flow.

Based on the formulated new principles, a new fuel combustion technology has been developed and proposed that meets the requirements of integrated environmental safety, efficiency and reliability for combustion devices.

In order to study the combustion process of the resulting coal-water fuel, a device was assembled consisting of gas atomizer, atomizers for spraying liquid fuel, air nozzles, nozzles, combustion chambers, coal-water fuel tanks, pipes for supplying coal-water fuel, tables, mixers and engines.

The simplest atomizers, for example, gas atomizers have one hole, and an atomizer with six holes is needed in our case for better dispersion when burning coal-water fuel. Compressed air up to 0.6 MPa coming from a compressor was used as a nebulizer.

The following Fig. 8 shows a photo of the flame when the gas is turned on. The principle of operation is formulated as follows: the resulting coal-water fuel is fed into the fuel tank. The gas cylinder and the atomizer are turned on. Using a gas atomizer, the combustion chamber and the atomizer that sprays liquid fuel are heated. For better suspension delivery, we connect a mixer to the tank. After the combustion chamber and the atomizer are heated to the desired temperature,

we use a compressor to feed the wet carbon fuel into the tank. Further, coal-water fuel enters the fuel supply pipeline. After lifting the coal-water fuel, the nozzle is opened, connected to the pipe, the fuel is sprayed through the atomizer into the combustion chamber. At the same time, the combustion process of coal-water fuel is controlled.



Fig. 8. Photography of a flame from a gas nozzle

In order to burn liquid fuel and obtain acceptable results, there should be a high temperature for a long time in the combustion chamber with the complete combustion of liquid fuel.

In the “Physics of Combustion” laboratory, the study and combustion of coal-water fuel were carried out in the following way. The primary hearth was heated up to 600 °C with diesel fuel, and then liquid fuel was pumped with compressed air into the atomizer for injection of coal-water fuel from the cell at a temperature of 750 °C. After that, the supply of diesel fuel stopped, and the combustion of the coal-water fuel occurred spontaneously. The combustion process lasted up to 30 minutes.

Fig. 9 shows a diagram of the temperature dependence of the combustion of coal-water fuel on the time of burning.

As can be seen from the figure, the heating temperature of the hearth with diesel fuel reached 650 °C for 20 minutes, after which for 2 minutes there was a joint combustion of diesel fuel and coal-water fuel and the temperature reached 800 °C.

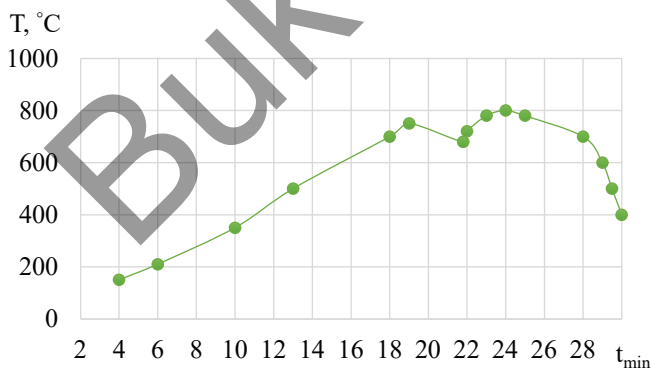

Fig. 9. Temperature dependence of coal-water fuel combustion

The temperature dependence of the combustion of coal-water fuel is obtained, where a cone is used in the nozzle, passing into a cylindrical outlet channel through a conjugate circular angular vertex. The duration of the experiment was up to 30 minutes. We have also tested an

advanced version of the nozzle, with a tangential twist for spraying coal-water fuel.

Then the supply of diesel fuel was stopped, spontaneous combustion of coal-water fuel occurred. But after the diesel fuel supply was stopped, the combustion temperature of coal-water fuel dropped sharply and within 6 minutes it decreased from 780 °C to 400 °C.

Fig. 10 shows that the flame is weak. With continuous combustion, we reduce the gas supply, at this moment spontaneous combustion occurs. A photo of the fuel combustion is shown in Fig. 10.



Fig. 10. Photographing the combustion process of coal-water fuel

How the process of burning fuel occurs is seen in the Fig. 10. Compared to gas combustion, fuel combustion is more intense.

During operation, the atomizers emitted high-pitched sounds characteristic of vibratory combustion, when gas atomizers were operating, and this phenomenon was constant. A mixer was installed at the bottom of the tank to prevent fuel from settling in the tank. The mixer was constantly rotating with the help of an engine. The adjustable gas atomizer was attached to the tripod.

However, the developed and tested first version of the nozzle requires further improvement of the design, because sometimes there is a blockage of the passing section when spraying coal-water fuel.

Next, we proposed a second version of the nozzle design for more active spraying and burning of coal-water fuel. The burner contains a nozzle with an aerodynamic twist, which contributes to the vortex flow of the coal-water mixture into the working space of the furnace.

For an experimental coal-water fuel combustion atomizer with a cylinder-radial sprayer, an experimental setup was assembled.

This burner device ensures a rational distribution of fuel in the oxidizer flow and a high level of turbulence intensity in the area of fuel mixture formation. Provides a stable controlled aerodynamic structure of the flow of fuel, oxidizer and combustion products with zones of reverse currents in the area of stabilization of the torch.

The principle of operation is as follows: coal-water fuel enters the cell, where we close the cell lid tightly. Then we preheat the combustion chamber to the required temperature and start the system.

Unlike the first version of the burner device, where a cone is used as an internal channel, passing into a cylindrical output channel through a conjugate circular angular vertex, the pro-

posed second design has a tapering smooth transition, excluding a circular angular vertex. The disadvantage of the design with a circular angular vertex is the narrowing of the passage section due to the formation of a dead circulation zone at the mouth of the transition from the cone to the cylindrical outlet.

Coal-water fuel is similar to liquid fuel, and when transferring heat generating plants to the combustion of this suspension, no significant changes in the design of boilers (units) are required. This makes it possible to easily mechanize and automate the processes of receiving, feeding and burning fuel and the vortex combustion technology at a temperature of 950–1050 °C guarantees fuel efficiency of over 97 % (with layered coal burning, this value does not exceed 60 %).

In connection with the above, for the combustion of coal-water fuel prepared using the electric pulse method, special burner devices are needed to ensure the continuous operation of the installation. In the future, these technologies for the preparation of coal-water fuel can be used by small boiler houses providing heat to detached buildings.

6. Discussion of the results obtained in determining the geometric and energy parameters of an electrohydroimpulse installation and obtaining coal-water fuel with subsequent combustion

During operation, the coal was pre-crushed mechanically and using an electrohydraulic effect.

As can be seen from the graphs (Fig. 3), the grinding process occurs in fractions with a diameter of $d_f=500-1000$ microns. At the beginning of the process, at $l_w=7$ mm, the volume of this fraction takes about 65 %, and at $l_w=10$ mm it decreases to 23 % (Fig. 4, $d_m=7-9$ mm).

Experimental studies show that the electrohydroimpulse method allows optimizing the granulometric composition, as well as reducing the mechanical impurity of finished products. At the same time, it is possible to accurately determine the required discharge energy to obtain a ready and homogeneous finished suspension, the installation itself allows grinding coal sludge and coal with a fraction diameter of 0–250 microns. With an increase in the discharge energy in the crushing and grinding unit, the content of the initial fraction decreases to 23 %.

As studies show (Fig. 4–6), the traditional grinding method based on well-known principles has many significant drawbacks, they implement the physical principle of material destruction by mechanical compression stresses, the resistance of which for rocks is 10–30 times higher than the rupture stress, and the efficiency of mechanical destruction remains very low.

From the results obtained on the Tescan Mira 3 electron microscope (Fig. 7), it can be seen that the diameters of the fraction of the processed material on the electrohydroimpulse unit are significantly smaller than those of the fraction processed in the traditional way. The electrohydroimpulse method acts much more selectively on the processed object and allows obtaining the necessary fractions and further use

of coal powder in coal-water fuel and there is no need to dehydrate the resulting product. Finished products can be used directly in the furnaces of boiler equipment.

After obtaining the necessary suspension, we obtained the temperature dependence of the combustion of coal-water fuel (Fig. 9). The duration of the experiment was up to 30 minutes. However, the developed and tested first version of the nozzle requires further improvement of the design, since when spraying coal-water fuel, a blockage of the flow section sometimes occurs.

Further, a nozzle with a radial-cylindrical sprayer is assembled for burning coal-water fuel, which provides a stable controlled aerodynamic structure of the flow of fuel, oxidizer and combustion products with backflow zones in the flare stabilization zone.

The advantage of the technology of obtaining alternative energy sources from untreated coal is undeniable, since the main factor in obtaining a coal-water suspension are shock waves accompanying an underwater electric explosion. Electrohydroimpulse processing allows not only grinding raw materials, but also significantly changing the structure and composition of the processed raw materials, since an underwater electric explosion passes through the particles and separates the resulting valuable components from the mineral base, by increasing the degree of processing of natural coal. At the same time, energy consumption in the production of coal-water suspension is reduced by 3–5 times, since the materials under study are processed by electric discharge directly in the liquid. However, to create an electrohydroimpulse installation with a crushing and grinding unit for introduction into production, additional financial investments are required.

The disadvantage of this study is that experimental work was carried out only in laboratory installations. The energy industry is skeptical about the new rational proposals.

7. Conclusions

1. The optimal parameters of the electrohydroimpulse installation were determined: the capacitance of the capacitor bank 0.75 μ F, the pulse voltage in the range from 15 to 30 kV, the length of the interelectrode distance from 7 mm to 10 mm.

2. It was found that the proposed nozzle with a cylindrical-radial sprayer provides a rational distribution of fuel in the oxidizer flow and a high level of turbulence intensity in the mixing zone. Provides a stable controlled aerodynamic structure of fuel, oxidizer and combustion products flows with the presence of reverse zones in the flame stabilization zone.

Acknowledgments

Some materials of this work were obtained and funded within the framework of the grant of the Ministry of Education and Science of the Republic of Kazakhstan “The best university teacher–2021”.

References

1. Davidsson, S., Grandell, L., Wachtmeister, H., Höök, M. (2014). Growth curves and sustained commissioning modelling of renewable energy: Investigating resource constraints for wind energy. *Energy Policy*, 73, 767–776. doi: <https://doi.org/10.1016/j.enpol.2014.05.003>
2. Dolinskiy, A. A., Khalatova, A. (2007). Vodougol'noe toplivo: perspektivy ispol'zovaniya v teploenergetike i zhilishno-kommunal'nom sektore. *Prom. Teplotekhnika*, 29 (5) 70–79. Available at: <http://dspace.nbuv.gov.ua/bitstream/handle/123456789/61288/11-Dolinsky.pdf?sequence=1>

3. Kuznetsov, G. V., Salomatov, V. V., Syrodoy, S. V. (2015). Numerical simulation of ignition of particles of a coal–water fuel. *Combustion, Explosion, and Shock Waves*, 51 (4), 409–415. doi: <https://doi.org/10.1134/s0010508215040024>
4. Murko, V. I., Kulagin, V. A., Baranova, M. P. (2017). Obtaining Stable Binary Fuel Systems. *Journal of Siberian Federal University. Engineering & Technologies*, 10 (8), 985–992. doi: <https://doi.org/10.17516/1999-494x-2017-10-8-985-992>
5. Guy, B. M., Hermes, M., Poon, W. C. K. (2015). Towards a Unified Description of the Rheology of Hard-Particle Suspensions. *Physical Review Letters*, 115 (8). doi: <https://doi.org/10.1103/physrevlett.115.088304>
6. Mosa, E., Saleh, A., Taha, A., El-Molla, A. (2007). A study on the effect of slurry temperature, slurry pH and particle degradation on rheology and pressure drop of coal water slurries. *JES. Journal of Engineering Sciences*, 35 (5), 1297–1311. doi: <https://doi.org/10.21608/jesaun.2007.114558>
7. Vershinina, K., Shevyrev, S., Strizhak, P. (2021). Coal and petroleum-derived components for high-moisture fuel slurries. *Energy*, 219, 119606. doi: <https://doi.org/10.1016/j.energy.2020.119606>
8. Korotkiy, I. A., Neverov, E. N., Murko, V. I., Chernikova, O. P. (2021). The development of ecologically clean technology for coal use in terms of the coal-water slurry usage. *Journal of Physics: Conference Series*, 1749 (1), 012044. doi: <https://doi.org/10.1088/1742-6596/1749/1/012044>
9. Dubrovsky, V. A., Isakov, Yu. V., Potilicyn, M. Yu., Potapov, I. I., Shirokov, V. N. (2010). Research of efficiency of electrohydraulic effects at reception cavitation water-coal of fuel for boiler installations of Krasnoyarsk region. *Vestnik Sibirskogo gosudarstvennogo aerokosmicheskogo universiteta imeni akademika M. F. Reshetneva*, 6 (32), 127–130. Available at: <https://cyberleninka.ru/article/n/issledovanie-effektivnosti-elektrohidravlicheskih-effektov-pri-poluchenii-kavitatsionnogo-vodougolnogo-topliva-dlya-kotelnyh>
10. Biletskyi, V. S., Krut, O. A., Svitlyi, Yu. H. (2011). Pryhotovannia vodovuhilnoho palyva na osnovi buroho vuhillia. *Zbahachennia korysnykh kopalyn*, 47 (88), 8–16.
11. Krut, O. A., Bilecky, V. S. (2013). Coal-water slurry fuel: current status and prospects. *Visnik Nacional'noi' akademii' nauk Ukraïni*, 8, 58–65. doi: <https://doi.org/10.15407/visn2013.08.058>
12. Biletsky, V., Sergeev, P., Krut, O. (2013). Fundamentals of highly loaded coal-water slurries. *Mining of Mineral Deposits*, 105–114. doi: <https://doi.org/10.1201/b16354-19>
13. Kurytnik, I. P., Nussupbekov, B. R., Khassenov, A. K., Nussupbekov, U. B., Karabekova, D. Z., Bolatbekova, M. (2022). Development of a grinding device for producing coal powder-raw materials of coal-water fuel. *Archive of Mechanical Engineering*, 69 (2), 259–268. doi: <https://doi.org/10.24425/ame.2022.140414>
14. Kurytnik, I., Nussupbekov, B. R., Khassenov, A. K., Karabekova, D. Z. (2015). Disintegration of Copper Ores by Electric Pulses/Rozdrobienie Rudy Miedzi Impulsami Elektrycznymi. *Archives of Metallurgy and Materials*, 60 (4), 2549–2552. doi: <https://doi.org/10.1515/amm-2015-0412>